

nEXO's Search for $0\nu\beta\beta$

Thomas Brunner (thomas.brunner@mcgill.ca)

For the nEXO Collaboration

SNOLAB Experiment Forum, February 8, 2024

The nEXO Search for $0\nu\beta\beta$ decay

Goal: observation of neutrinoless double beta decay ($0\nu\beta\beta$)

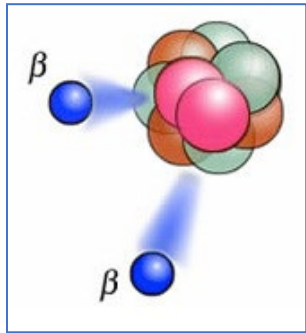

$0\nu\beta\beta$ only possible if neutrinos are special particles, so-called Majorana particles.

- **Observation would violate lepton number in weak decays**
- Observation would prove existence of a process in which matter is produced without equal amounts of anti-matter!

- nEXO in a nutshell:
 - Projected sensitivity of nEXO beyond 10^{28} years.
 - Search for $0\nu\beta\beta$ in a detector with 5 tonnes of liquid Xe.
 - Enriched to 90% in $\beta\beta$ decaying isotope Xe-136.
 - Apply well-established time-projection chamber technology.
 - SNOLAB in Sudbury is the preferred location for nEXO.

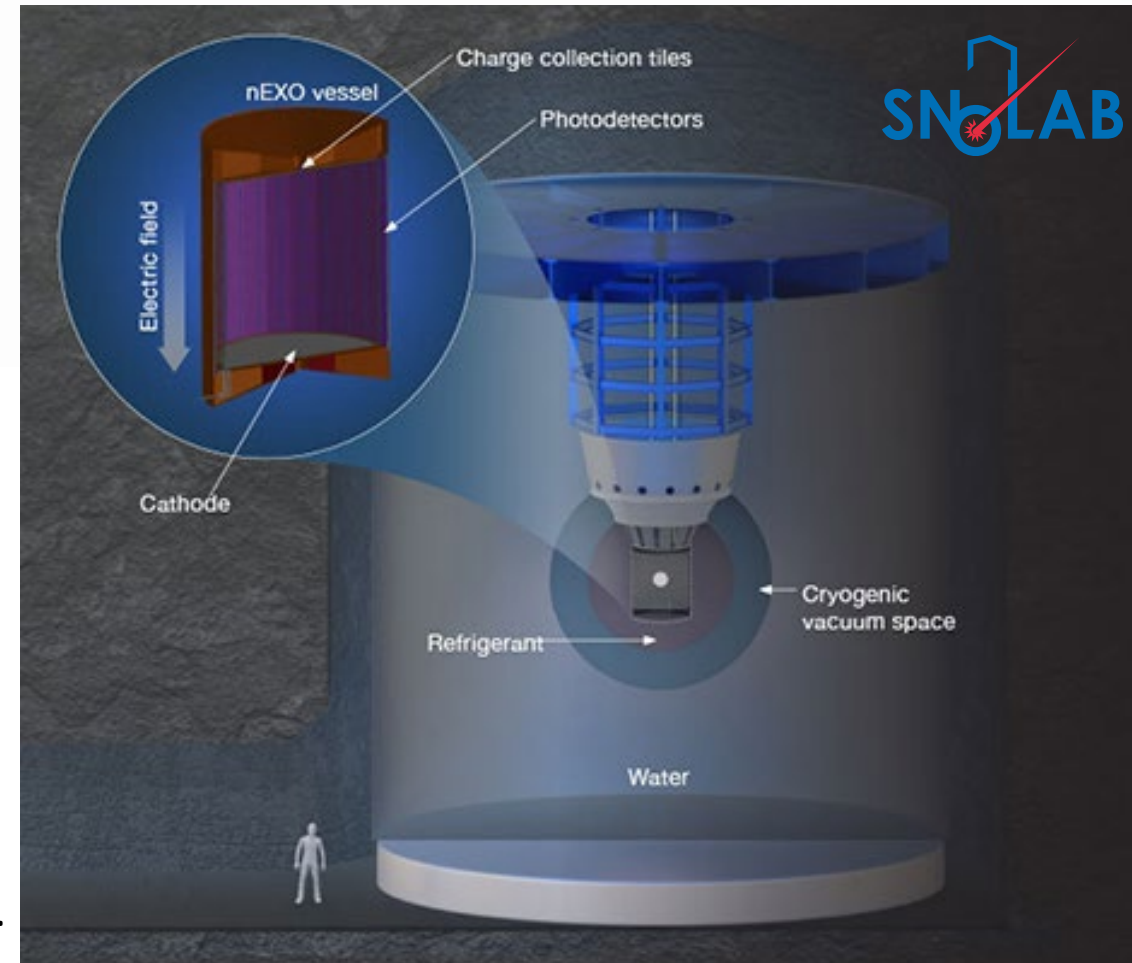

<https://nexo.llnl.gov/>

nEXO Projected Sensitivity

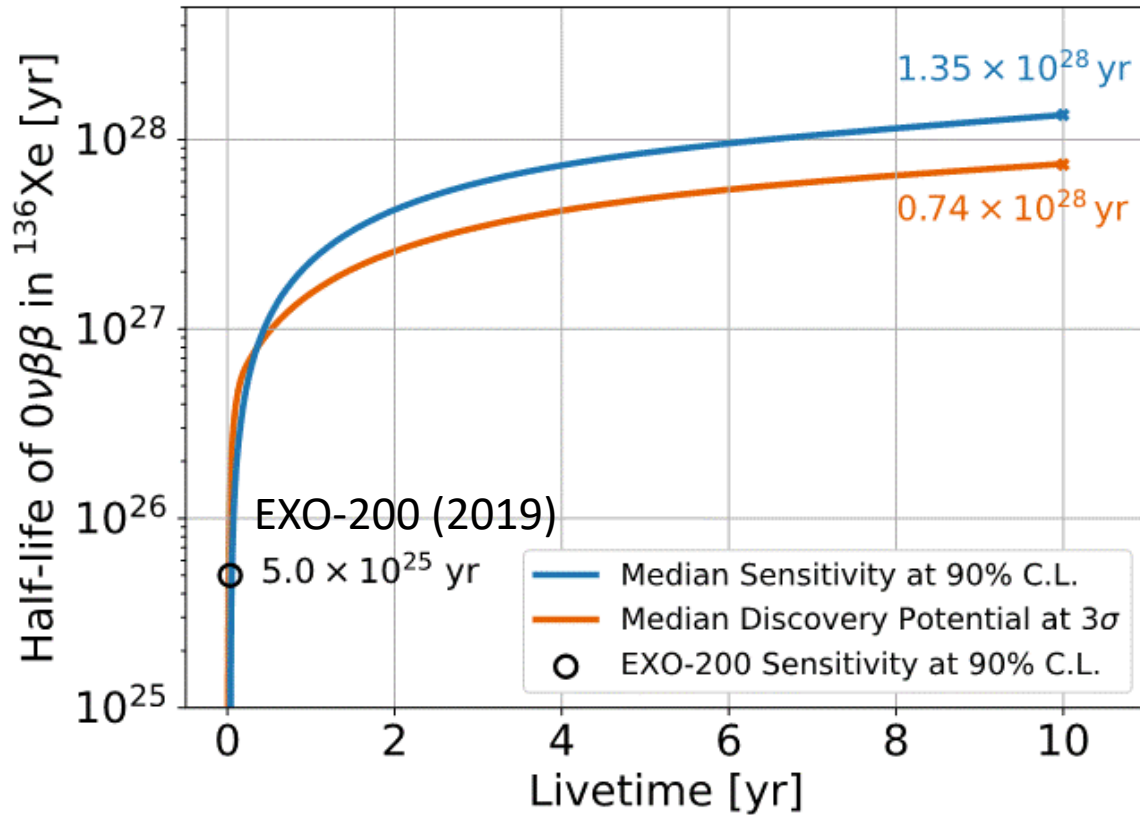

Allowed parameter space and nEXO exclusion sensitivity (90% CL):

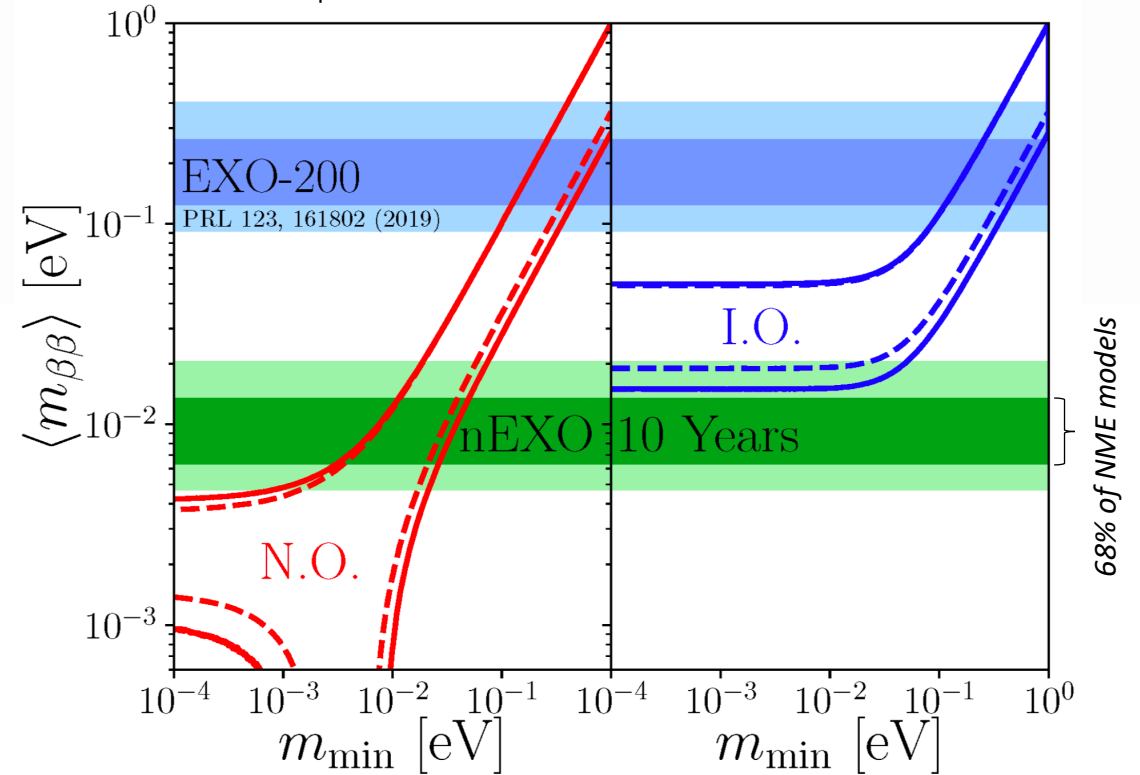

nEXO sensitivity reaches 10^{28} yr in 6.5 yr data taking

Projected sensitivity based on actual background level measurements!

The international nEXO collaboration



WELCOME to our newest members!

Canadian contingent within nEXO

- 15 PIs members of nEXO
- ~45 undergraduate and graduate students and postdocs
- Canadian groups constitute $\frac{1}{4}$ of the collaboration
- Significant engineering and project management support from SNOLAB

List of collaborators available at <https://nexo.llnl.gov/>



nEXO Code of Conduct (Committee)



- Ad Hoc Committee struck in 2018 to draft Code of Conduct
- Converted to Standing committee in 2019 to host Ombudsperson Elections
- Code of Conduct:
 - <https://nexo.llnl.gov/diversity-equity-inclusion>
 - Used by TUCAN and other collaborations to form their codes
 - Mentioned in SNOWMASS whitepaper as resource
- Offshoot: DEI Committee formed in 2020
 - Volunteer group of ~16 nEXO collaboration members who lead initiatives to increase the Equity, Diversity, and Inclusion of the Collaboration.

DEI Committee: Mentorship

- nEXO's Mentorship Program was developed to help establish professional relationships between collaboration members at different career stages in order to promote camaraderie and inclusion within nEXO.
- This program pairs undergraduate and early graduate students with more senior members of the collaboration to discuss a variety of topics such as science and career advice.
- Through the implementation of the Mentorship Program, nEXO has fostered a more welcoming working environment for early members of the science community.

- Over 3+ years, 48+ individual pairings.

- Hold events to socialize:
 - Group movie watch over zoom, “Majorana”
 - “Codenames” group game
 - “Powerpoint Party” slide deck on topic of choice
 - Laser Tag

Promotional Video:

https://youtu.be/O8UGn_E5F4g



DEI Committee: Ask Me Anything

- “Ask Me Anything” started at the first in-person meeting post-pandemic
- Senior Collaborators share their journeys in science/life
- Junior collaborators can ask any questions

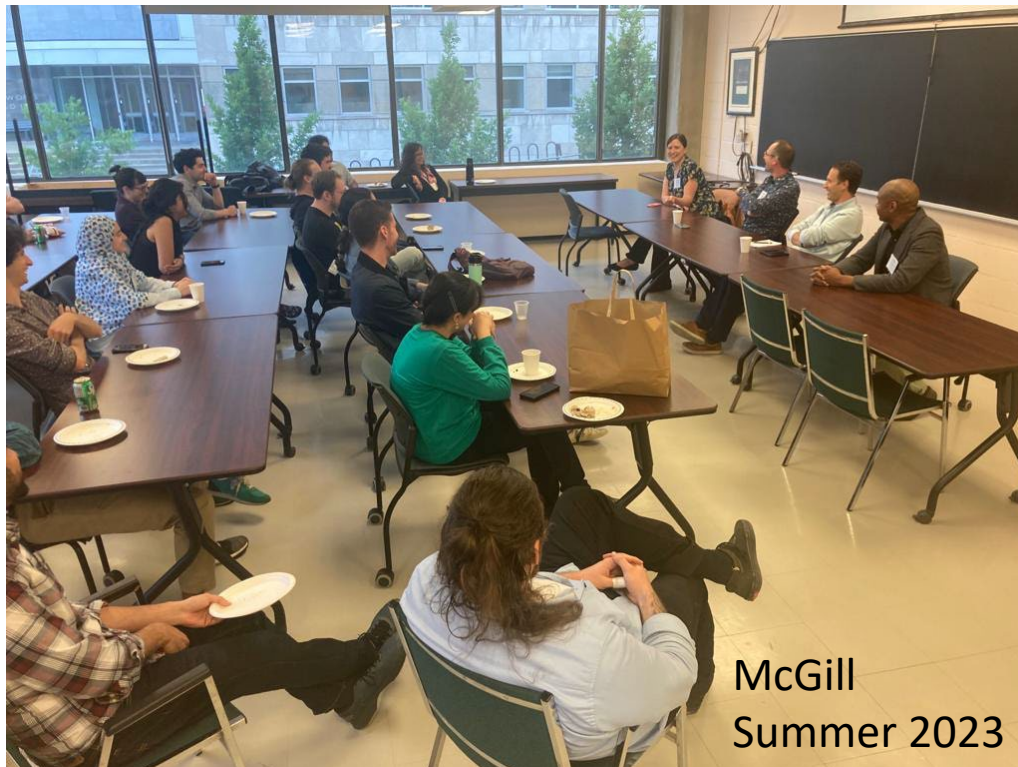

Experiment Status

- The collaboration continues with its design of the nEXO detector.
- R&D efforts are ongoing to design nEXO and optimize its performance.
- In the following slides some highlights from a Canadian perspective are presented. It is not a complete report on Canadian activities.

Canadian contributions to nEXO Project

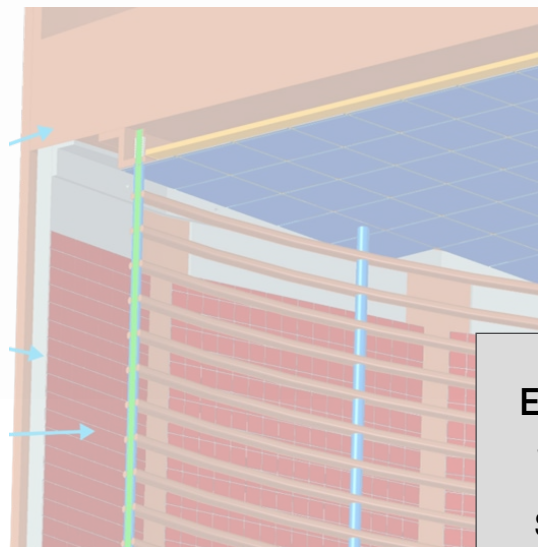

WBS with Canadian contributions

SNOLAB is the leading institution for two detector systems

Charge Readout Electronics (SLAC)
Subsystem Scientist: L. Yang (UCSD)
Subsystem Manager: A. Dragone (SLAC)

Photon Readout Electronics (BNL)
Subsystem Scientist: M. Chiu (BNL)
Subsystem Manager: L. DeMino (BNL)

TPC (PNNL)
Subsystem Scientist: J. Orrell (PNNL)
Subsystem Manager: A. Gorham (PNNL)

Photon Detector (BNL)
Subsystem Scientist: D. Moore (Yale)
Subsystem Manager: M. Worcester (BNL)

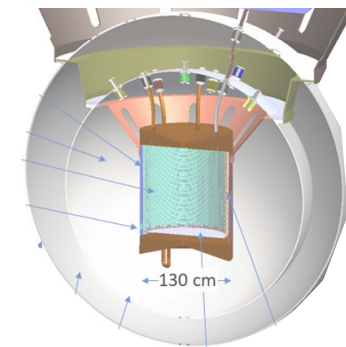

Computing, Control and Software (LLNL)
Subsystem Scientist: S. Sangiorgio (LLNL)
Subsystem Manager: TBD

Radioactive Background Control (SLAC)
Subsystem Scientist: A. Piepke (UA)
Subsystem Manager: TBD

TPC Support Systems (LLNL)
Subsystem Scientist: A. Pocar (Umass)
Subsystem Manager: A. House (LLNL)

Xenon (LLNL)
Subsystem Scientist: G. Gratta (Stanford)
System Manager: TBD

Facility (SNOLAB)
Subsystem Scientist: E. Caden
Subsystem Manager: D. Hawkins

Outer Detector (SNOLAB)
Subsystem Scientist: T. Brunner
Subsystem Manager: D. Hawkins

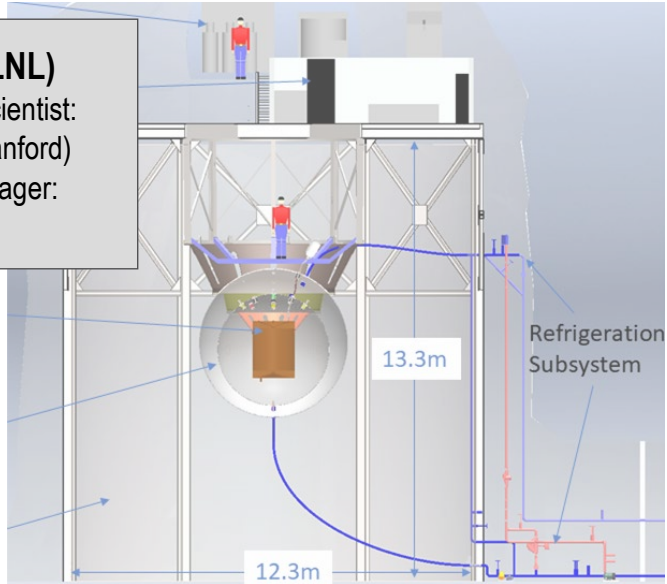

New Institutions

- University of Windsor joined nEXO with Caio Licciardi as PI (July 2023)
- UWindsor will contribute to:
 - MC simulations and data analysis
 - charge detection R&D
 - radon counting (L3 manager for the nEXO Rn program)
- SNOLAB joined nEXO with PIs Erica Caden and Nasim Fatemighomi (September 2023)
- SNOLAB lead institution for two detector subsystems:
 - Erica leads facility and muon veto work
 - Nasim leads Rn assay in water development



University
of Windsor



- Joined as new institution in September 2023 under PI Stephen Sekula
- Focus on planning for CFI IF 2025:
 - **Key deliverable: Radon Reduced Air (RRA) system.** Queen's ramping up to contribute to modular RRA construction. Sekula serves as L4 Manager for RRA system, part of the nEXO Clean Room Program. Coordinating with SNOLAB partners to establish cost and construction (and commissioning) plan.
 - Additional effort to coordinate with PNNL and other stakeholders on costs and scale of establishing underground (shallow or deep) **copper electroforming in Canada.**

- Skid based approach but with two larger vacuum pumps at lower costs
- This approach allows easy repurposing of system in sets of 100CFM for other uses in the lab post nEXO
- Multiple vacuum pumps to allow system run in reduced flow mode if a pump fails or tanks have to be taken offline
- Remote control of system provides reduced air flow based on needs
- All I/O on 2 tank skid is distributed I/O, all signals terminate directly on skid

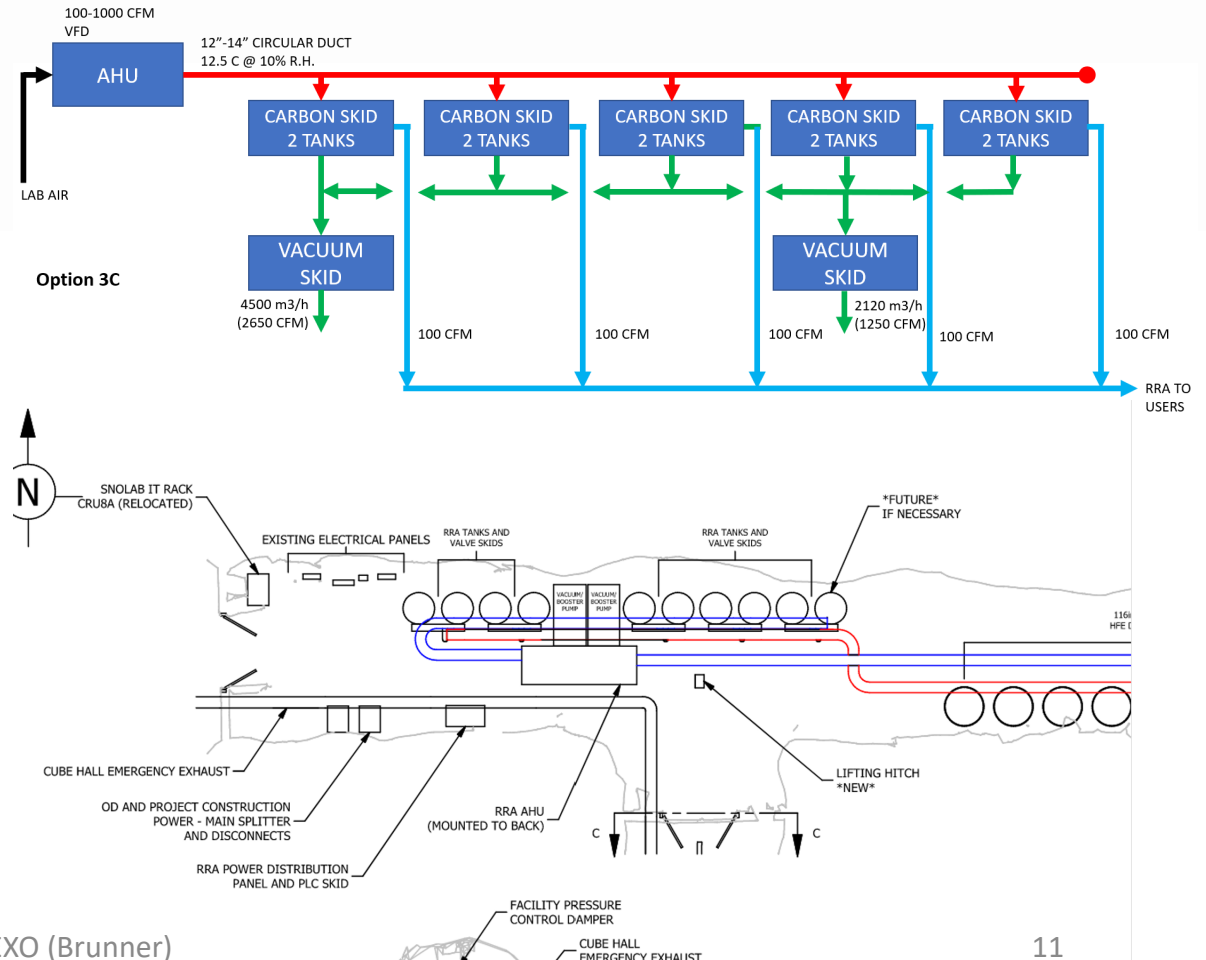

PMT testing

- nEXO plans to reuse 125 PMTs from Daya Bay for its muon veto.
- First box with PMTs decommissioned from Daya Bay arrived at LU in 2023.
- Initial setup to characterize PMTs and validate their functionality.
- Will need upgraded space for full testing of all PMTs.
- Upgrade dark box and electronics to test several PMTs at once.
- Erica Caden is the L3 manager for the muon veto system.



Voltage (V)	Dark Rate (kHz)
1460	30.67 ± 2.88
1510	29.75 ± 2.62
1560	30.65 ± 2.72

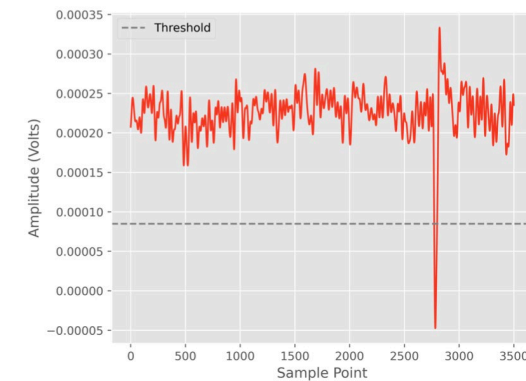

OD Calibration Development

PMT placement optimized for muon signals.

Calibration: Light source, externally controlled, looking at different diffuser ball concepts.

Synergy with Precision Optical Calibration Module used by IceCube and P-ONE (arxiv:2005.00778).

Investigating their diffuser-ball and housing.

Plans to adopt their design and fabricate two prototype devices for testing.

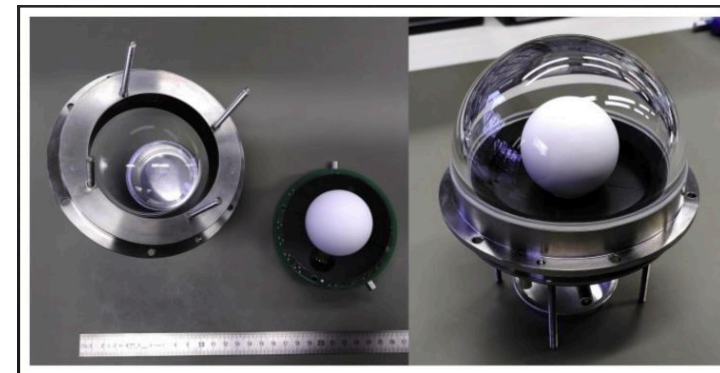
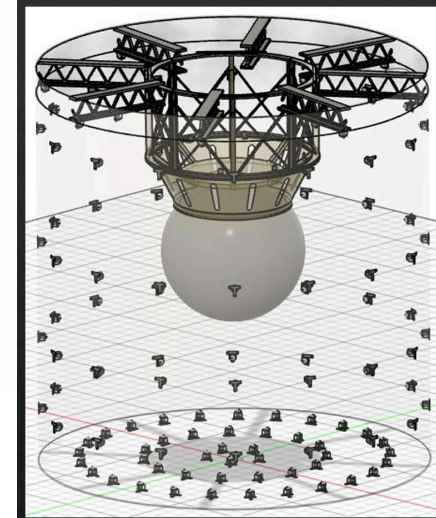
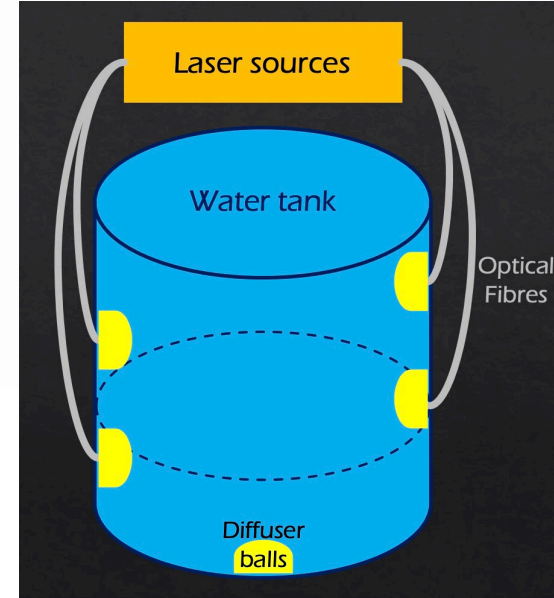

Photosensor R&D

Photon detection module: from counting photons to mechanical assembly UDS

The PDM concept

- Array of fully digital photon detectors
 - Photon-to-Digital Converters
 - Tile controller – data aggregation
 - Optical data communication
 - Power management
- Large tile units (~25 cm²)
 - Silicon interposer to limit radioactive background

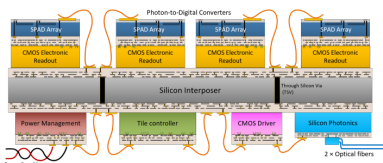

serge.charlebois@usherbrooke.ca

Photon-to-Digital Converter

- Digital from the start point
 - 1-to-1 SPAD to readout coupling
 - Reduced power – no need to digitize
- SPAD level control
 - Adjustable hold-off delay
 - Enable/disable noisy (deteriorated) SPADs
- Good timing capability < 200 ps

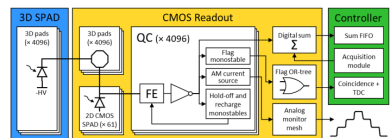

2

- R&D efforts for photon detection in liquid noble gas
- nEXO may benefit from technology developed by Sherbrooke collaborators

Photon-to-digital converters (PDC) and photon detection module (PDM): Answering the needs of noble liquid experiments

SNOLAB Experiment Forum 2024

S. A. Charlebois, J.-F. Pratte
Université de Sherbrooke, Sherbrooke, QC, Canada, J1K 2R1



Photon-to-Digital Converter development status UDS

- Wafer level 3D integration
 - Thinned SPAD layer bonded on a CMOS readout circuit
 - Front side illumination – p+n
 - 64 × 64 SPAD Array, 78 μm pitch
- First full devices to be completed summer 2024
 - Assembly of fake SPADs on real CMOS successful
- SPAD layer already characterized
 - PDE 56% @ 450 nm, DCR < 0.1 cps/μm², AP 10%, timing resolution 130 ps FWHM @ 410 nm
- CMOS operation confirmed

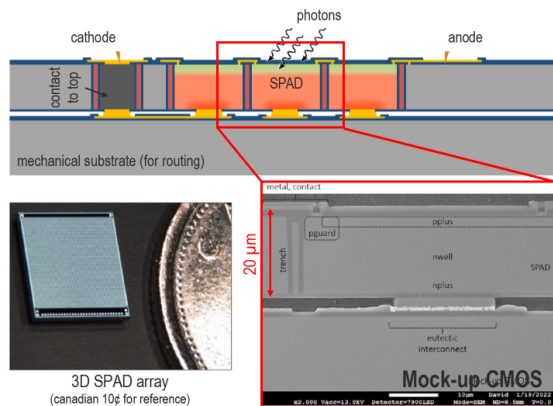

SEM cross section image

serge.charlebois@usherbrooke.ca

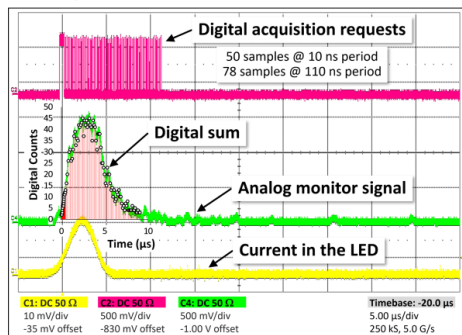

3

Ongoing efforts UDS

- PDC optimization
 - Increasing SPAD array fill factor
 - Field engineering to reduce DCR and AP
 - Surface band engineering to boost VUV sensitivity
- Large area silicon interposer demonstration
 - Phase 1: 200 mm test wafer Sherbrooke-TRIUMF-IZM interposer
- Optical communication module
 - No laser on the cold side
 - Silicon photonics components
 - CMOS 65nm Driver designed
- PDM demonstration
 - 2 × 2 tiles: operation demonstration
 - 8 × 8 tiles: fast neutron radiography
 - Developing tile controller
 - FPGA implementation
 - To be implemented on an ASIC



Phase 1: 200 mm test wafer Sherbrooke-TRIUMF-IZM interposer

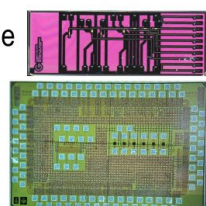
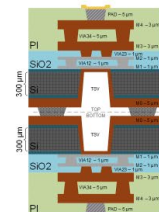

serge.charlebois@usherbrooke.ca



4

Schedule impacts & milestones

- A lot of exciting R&D is ongoing.
- nEXO design is making good progress.
- **Planning for Fall 2024 CD-1.**

- Canadian groups are preparing a CFI IF 2025 proposal in support of nEXO's construction at SNOLAB.

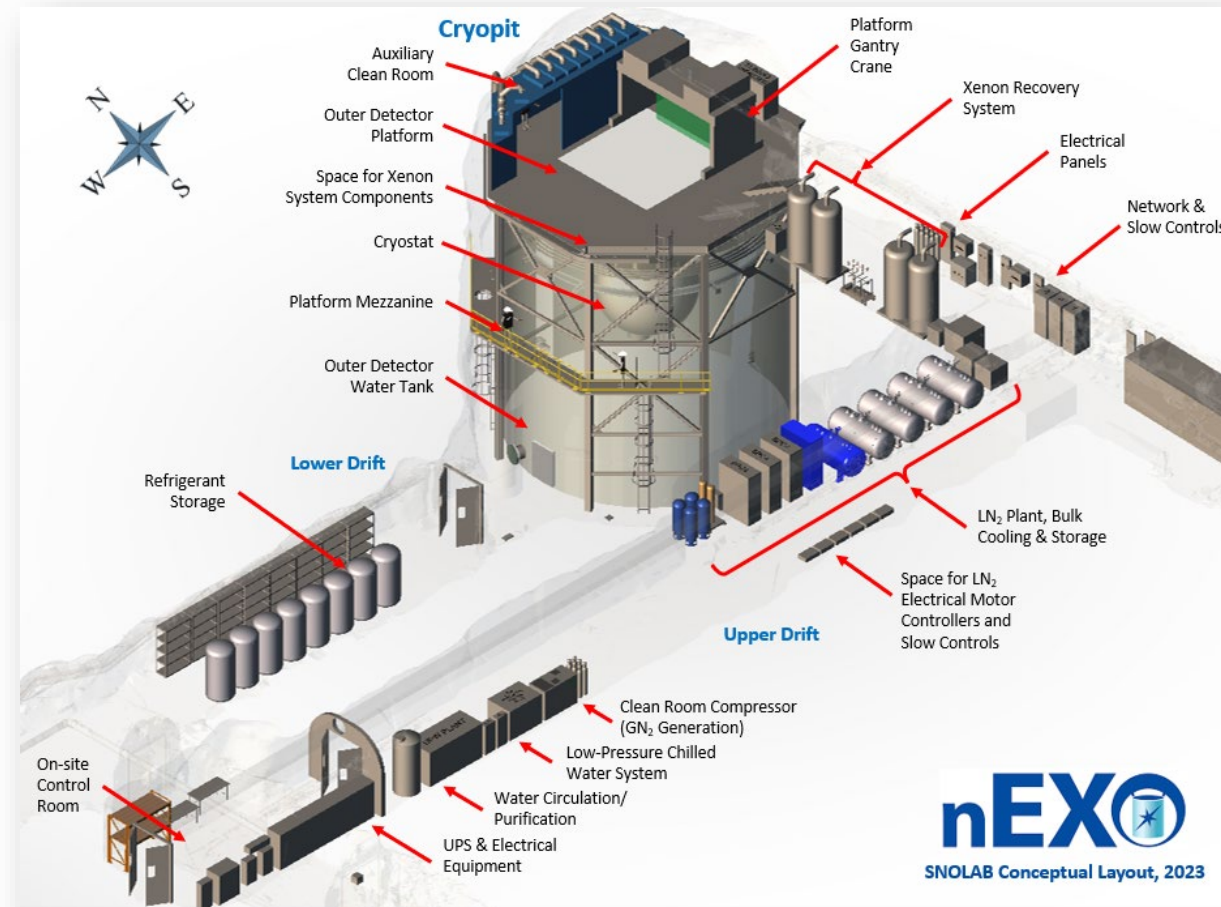

Summary

- nEXO continues taking on shape!
- Consider joining us in this exciting endeavor!

