

2026/05/27

# GPS Timing at SNOLAB

---

Tom Sonley  
Staff Scientist



# Multi-messenger Astronomy is the Future!



# Supernova 1987A

## Feb 24, 1987

In Large Magellanic Cloud @ 51.4 kpc  
 24 total neutrinos detected in 3 experiments  
 Estimated 2-3 hours before light from supernova reached earth

Demonstrated:

> 99% of gravitational energy converted to neutrinos (all flavours)

Energy scale O(10) MeV

Average Energies:

$$\langle \nu_e \rangle < \langle \bar{\nu}_e \rangle < \langle \nu_{\mu,\tau} \rangle$$

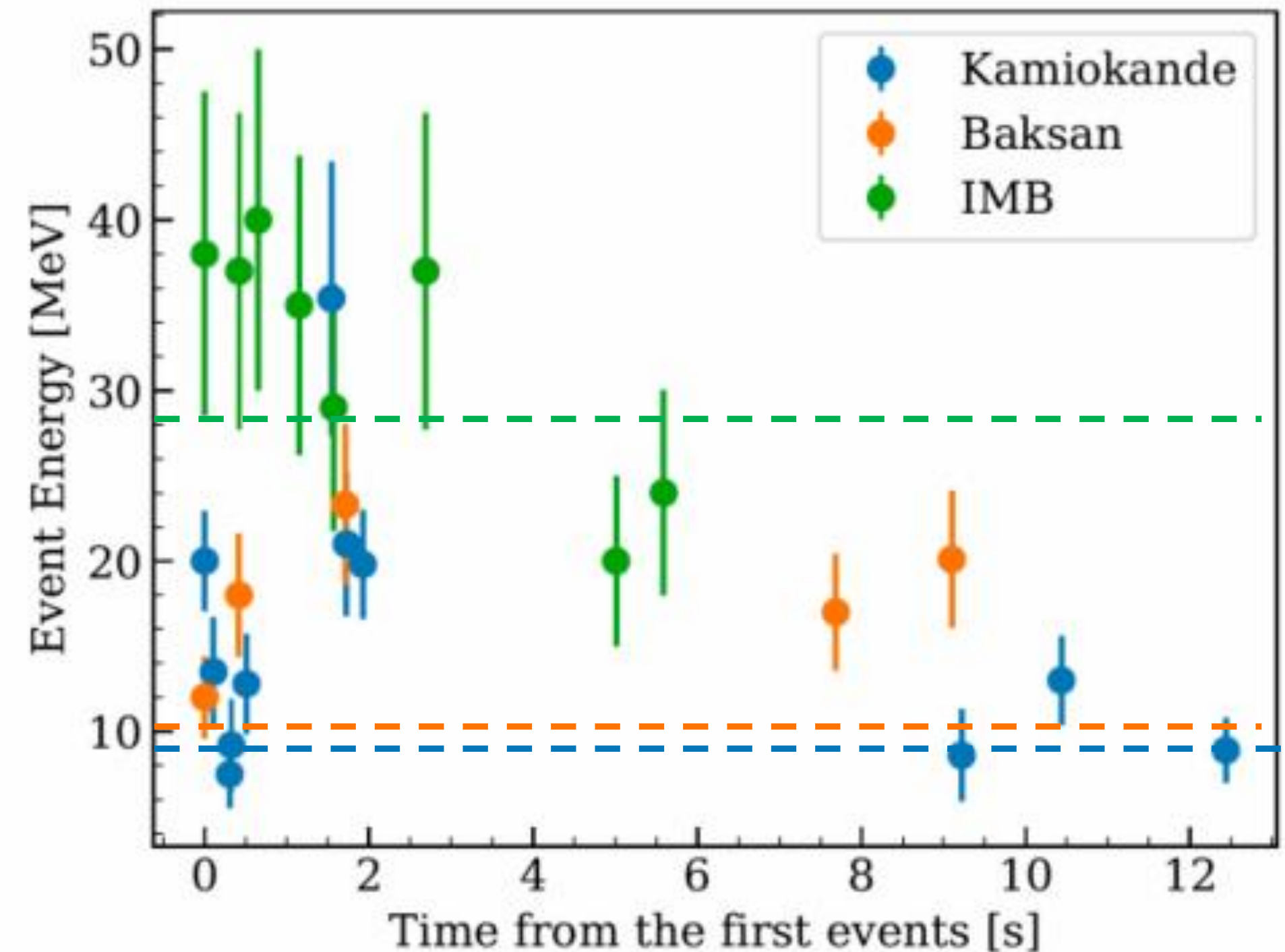

50% detection efficiency threshold

M. Mori

- [1] Hirata et al. 1987
- [2] Bionta et al. 1987
- [3] Alekseev et al. 1987

27-11



Sept 22, 2017  
290 TeV Neutrino  
Observed by IceCube

Pointed to Blazar:  
TXS 0506+056

TXS 0506+056

# GW170817 Neutron Star Merger

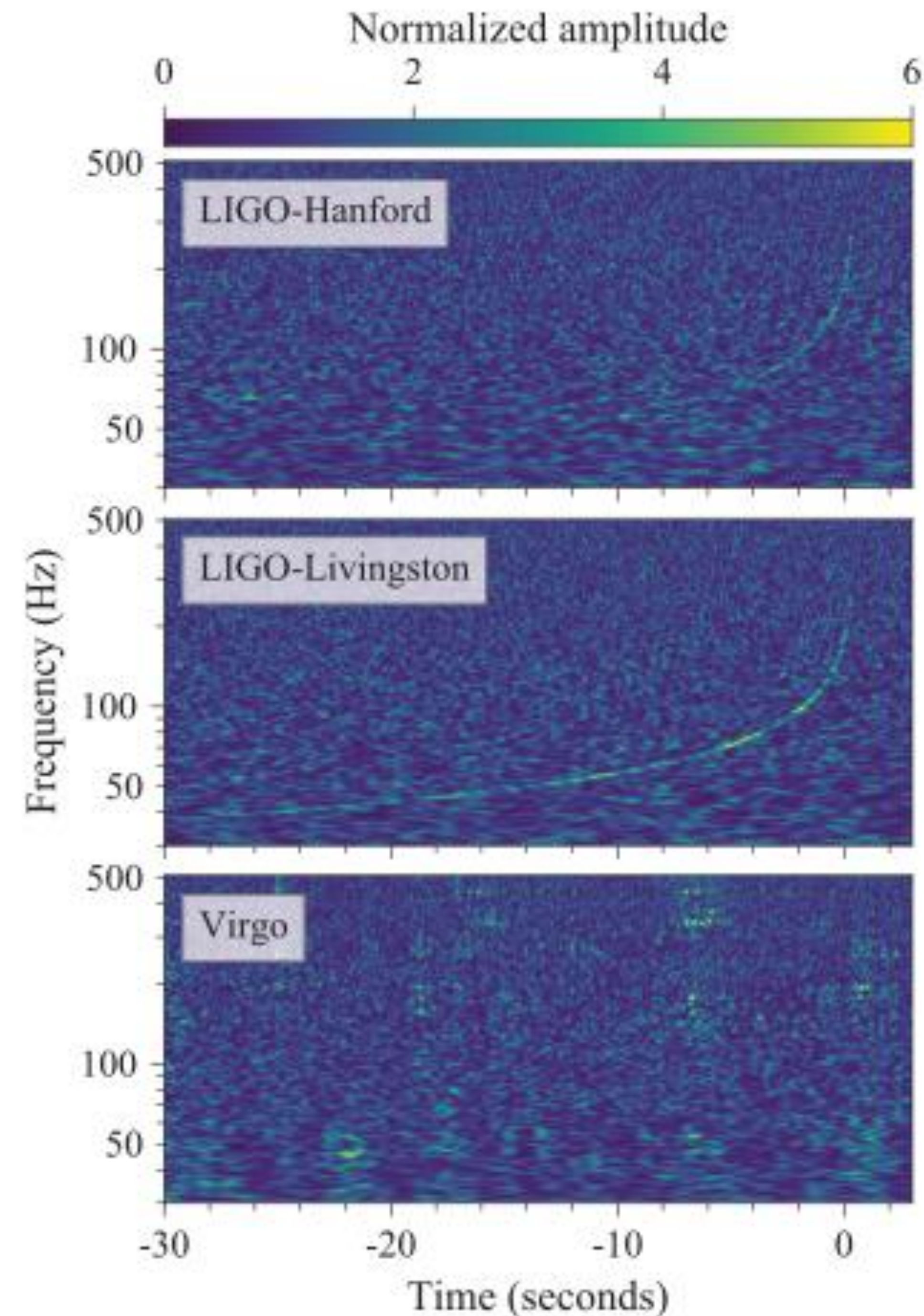

- Gravitational Waves observed by LIGO
- Short Gamma Ray Burst observed by satellites
- Followup in all EM Bands

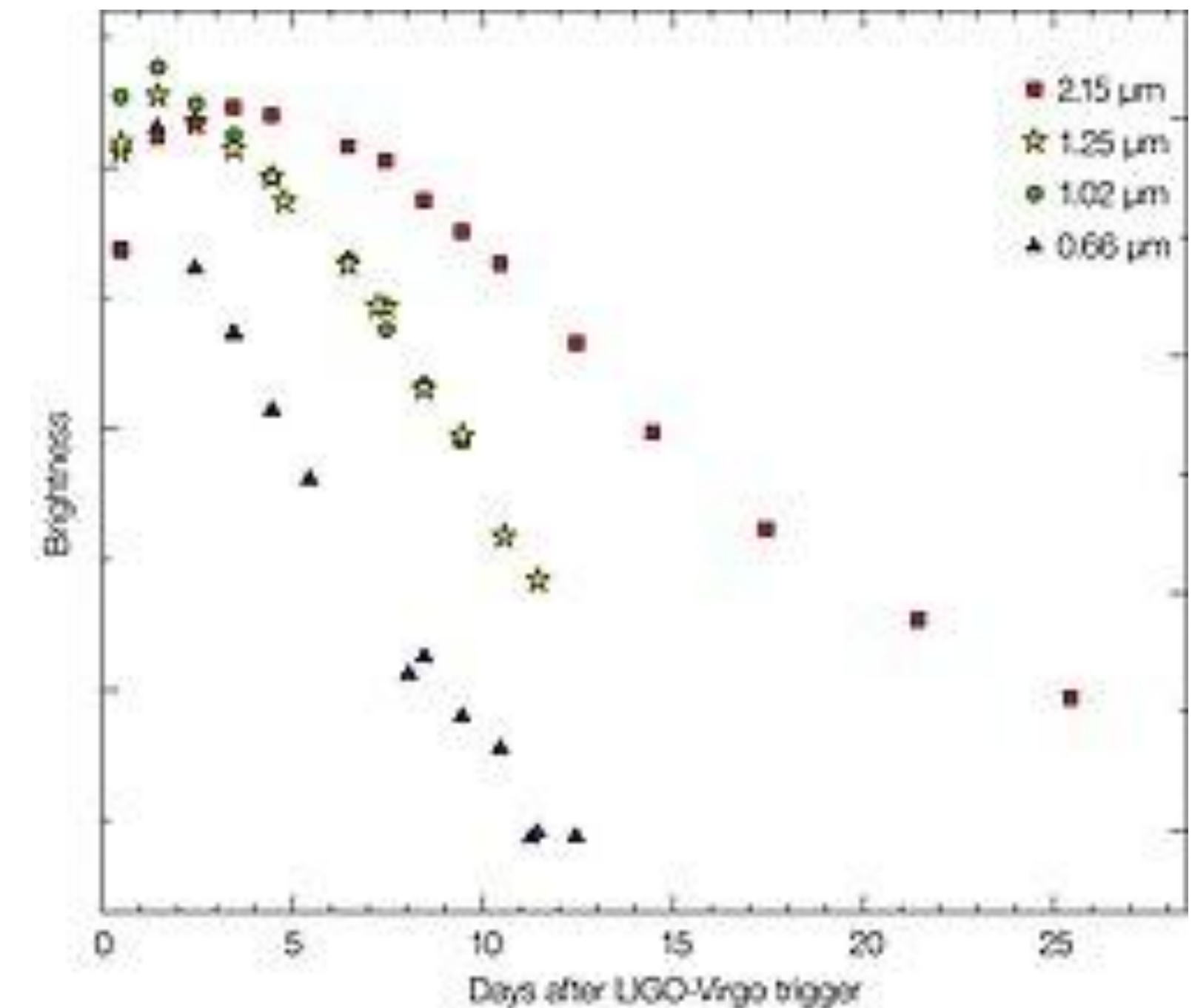

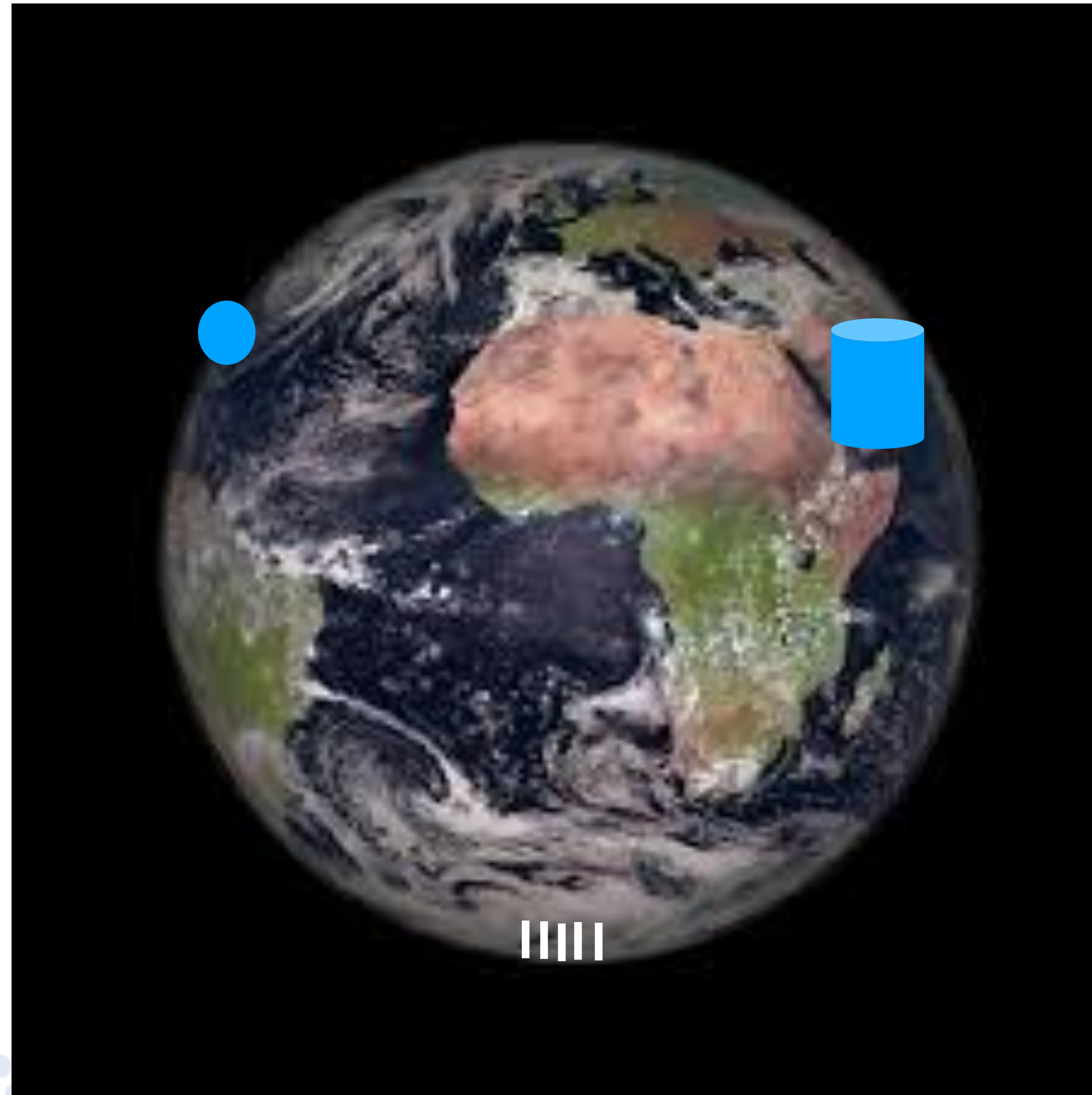

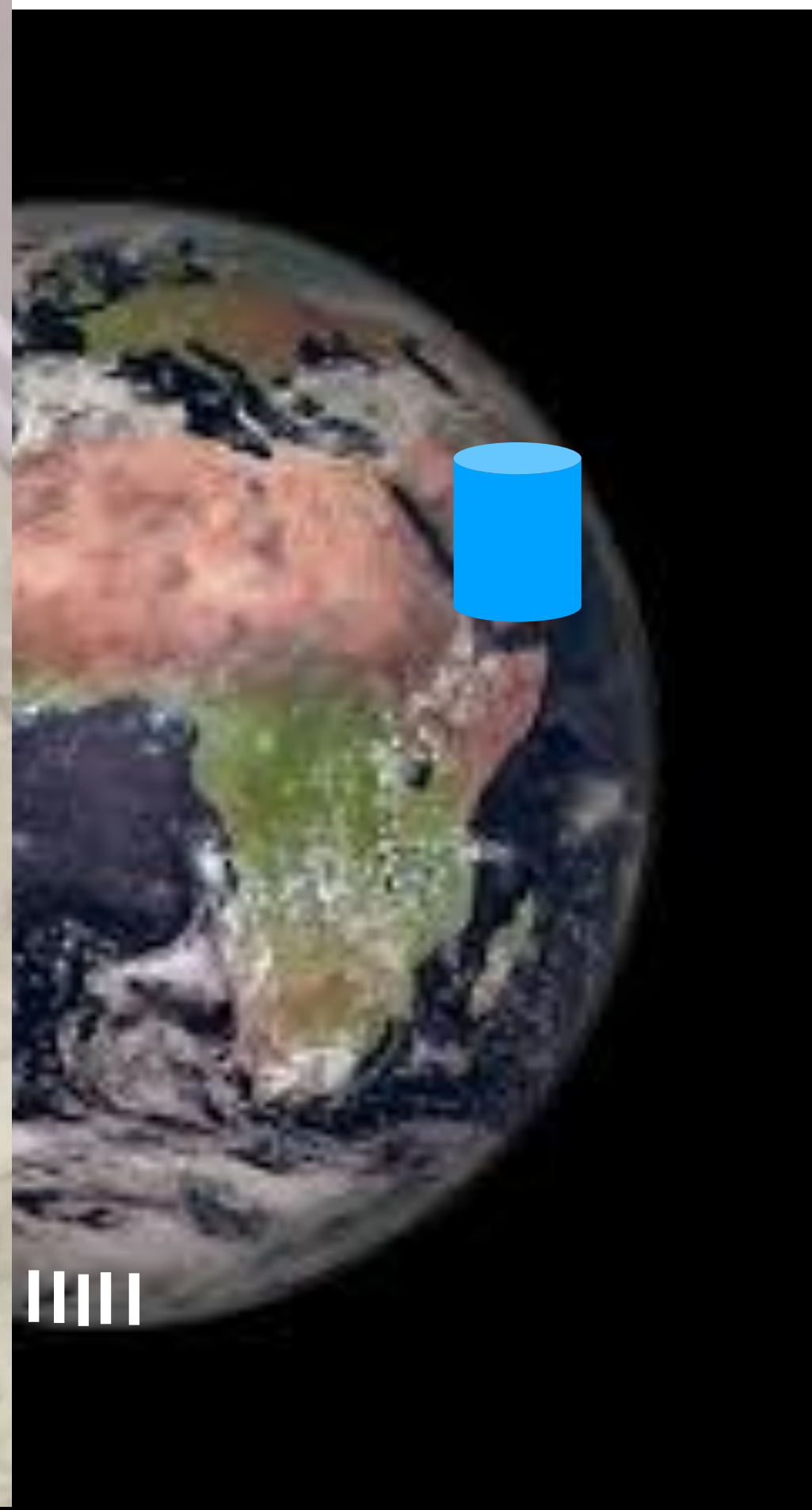

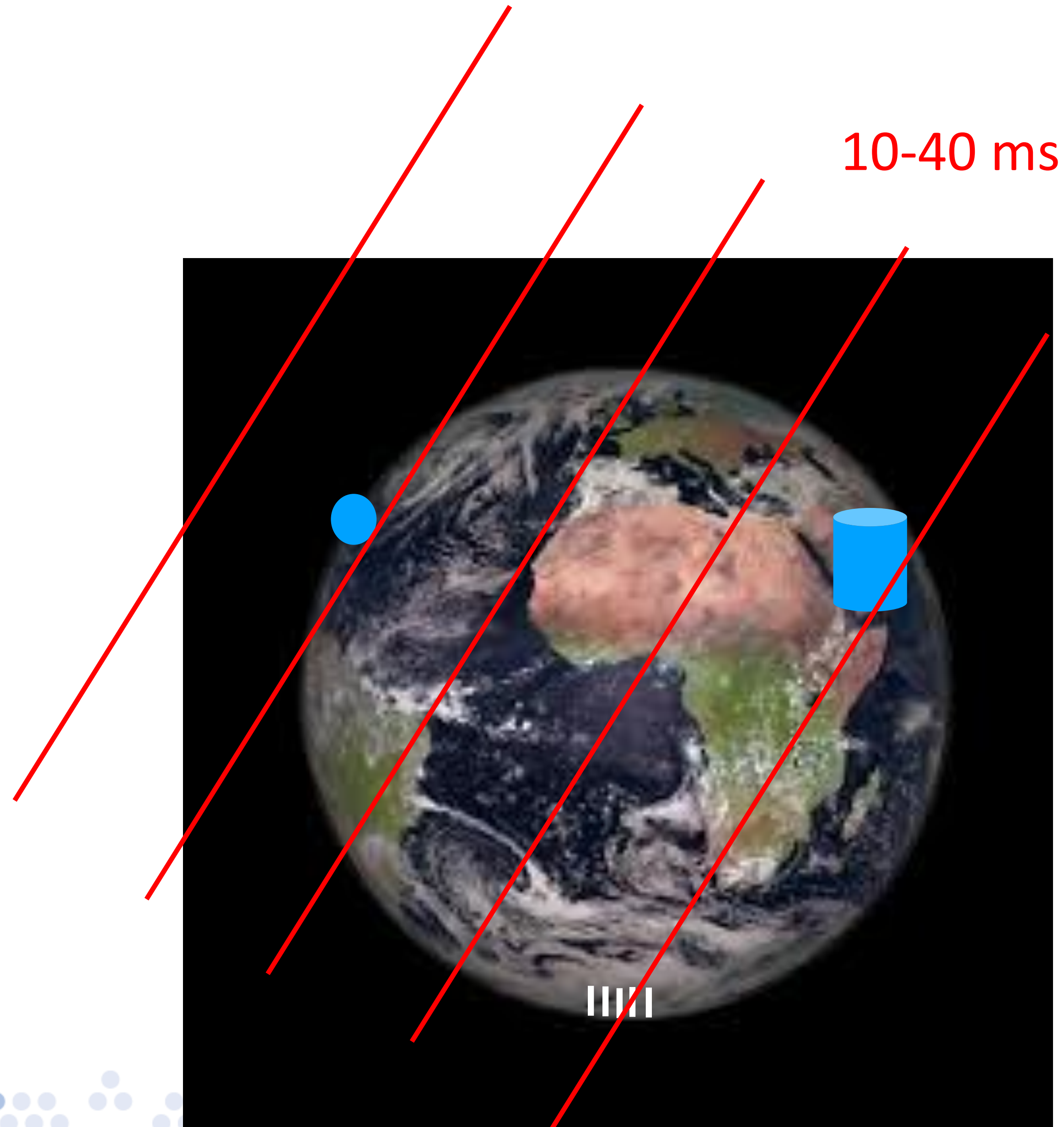



- GPS system provides few-ns timing worldwide.
- How do you get Satellite signals 2 km underground?

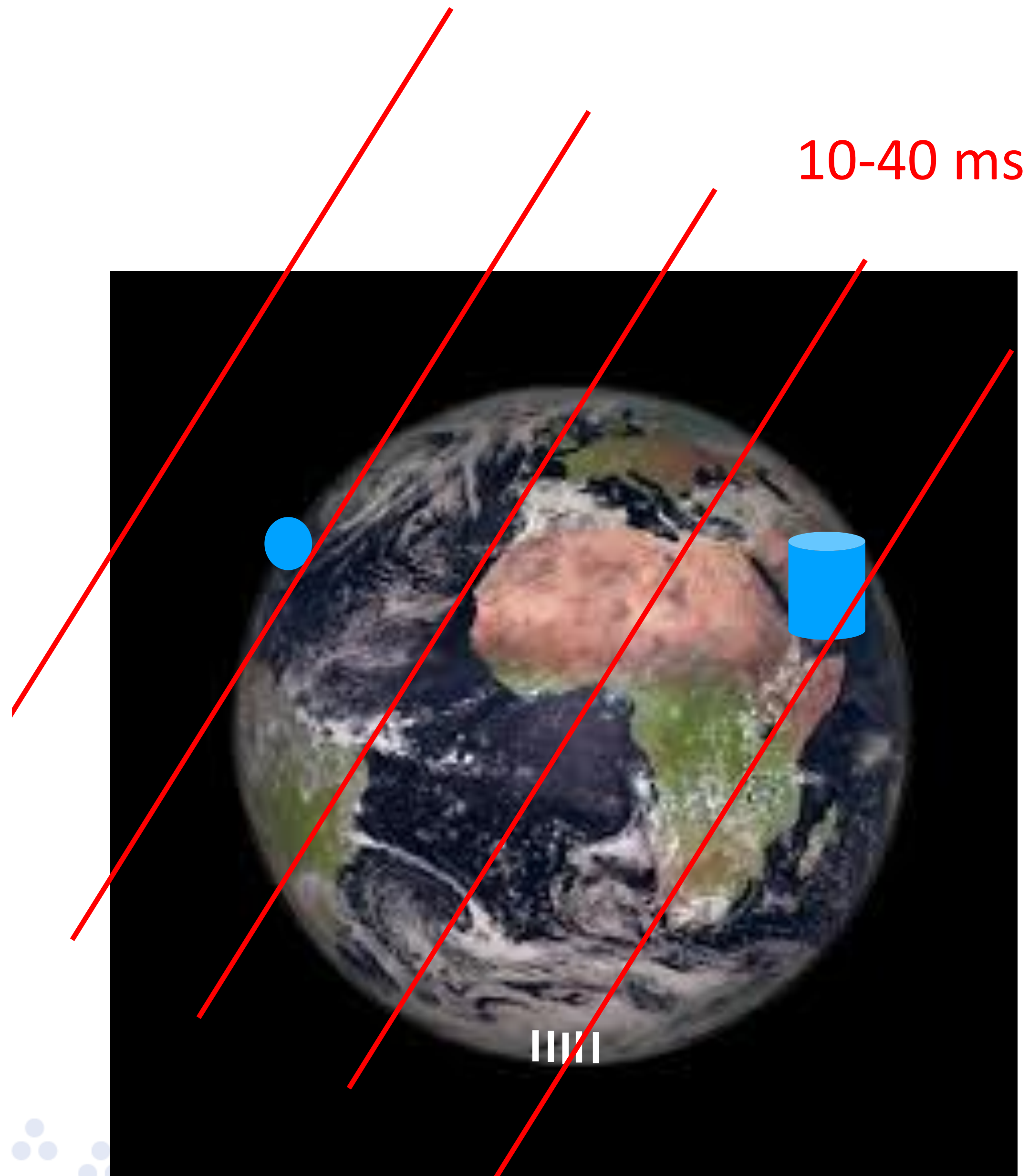

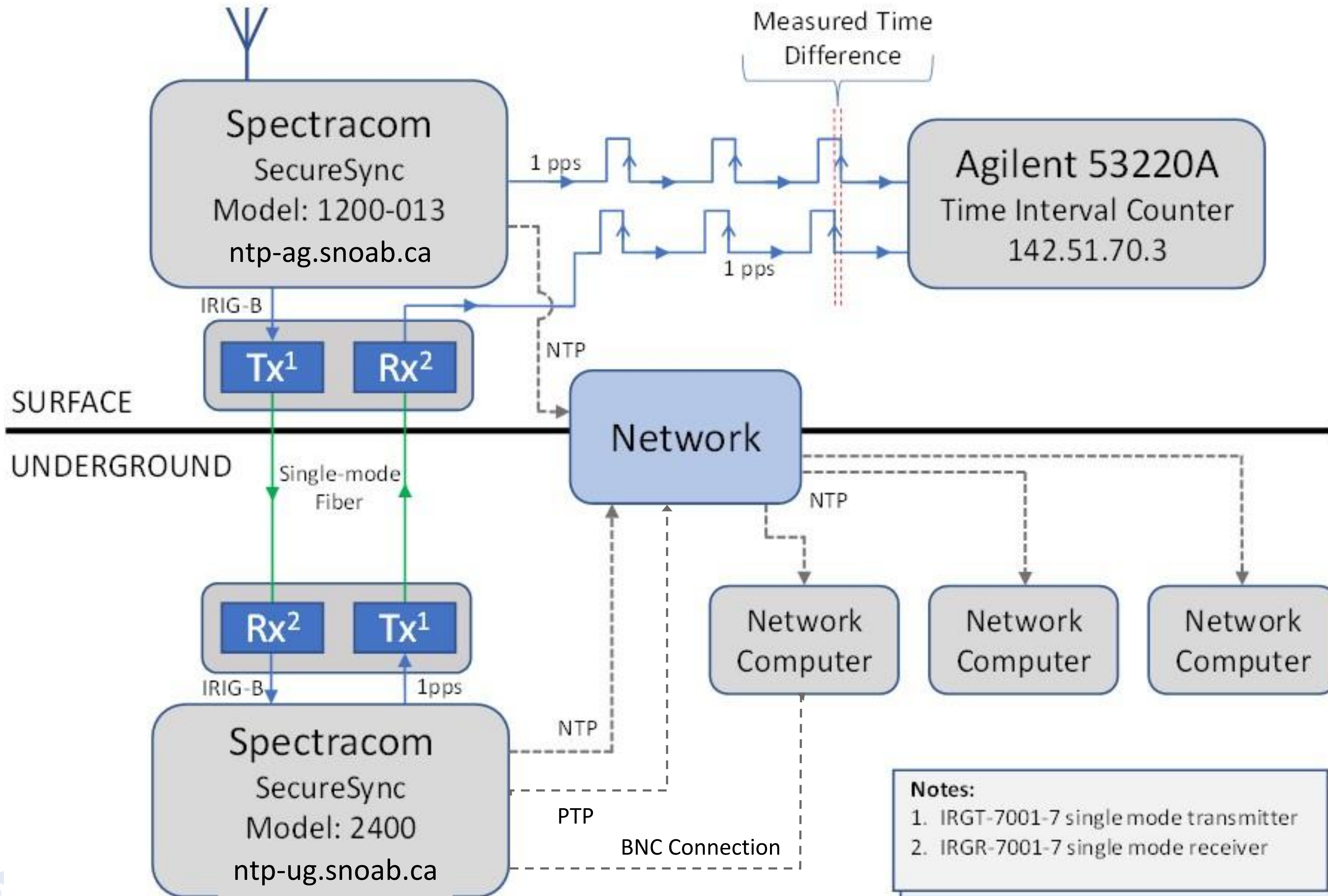

# NTP Protocol

- Easy
- All computers support this
- 20 us accuracy for HALO
- Watch for VLAN issues at SNOLAB

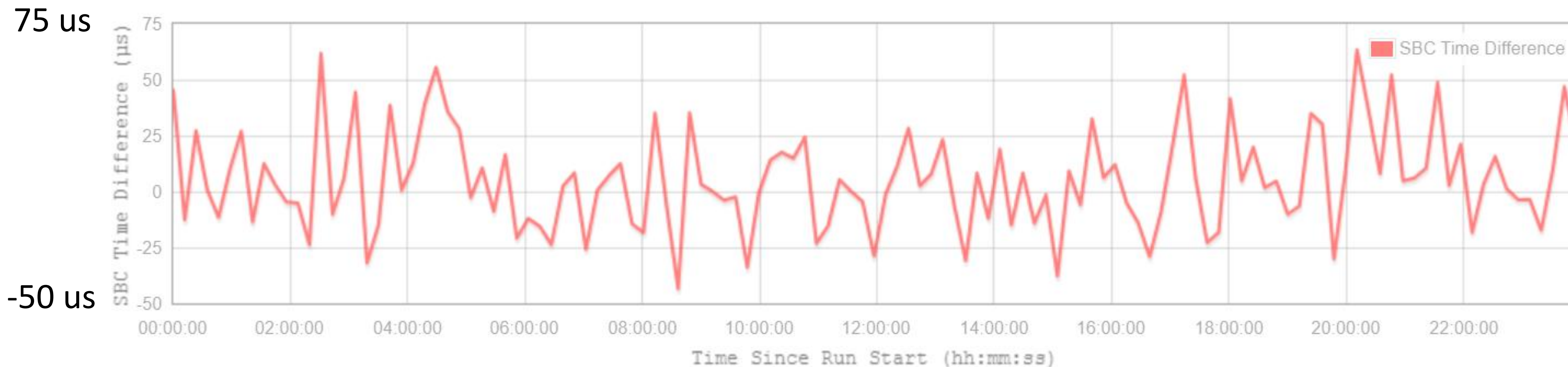
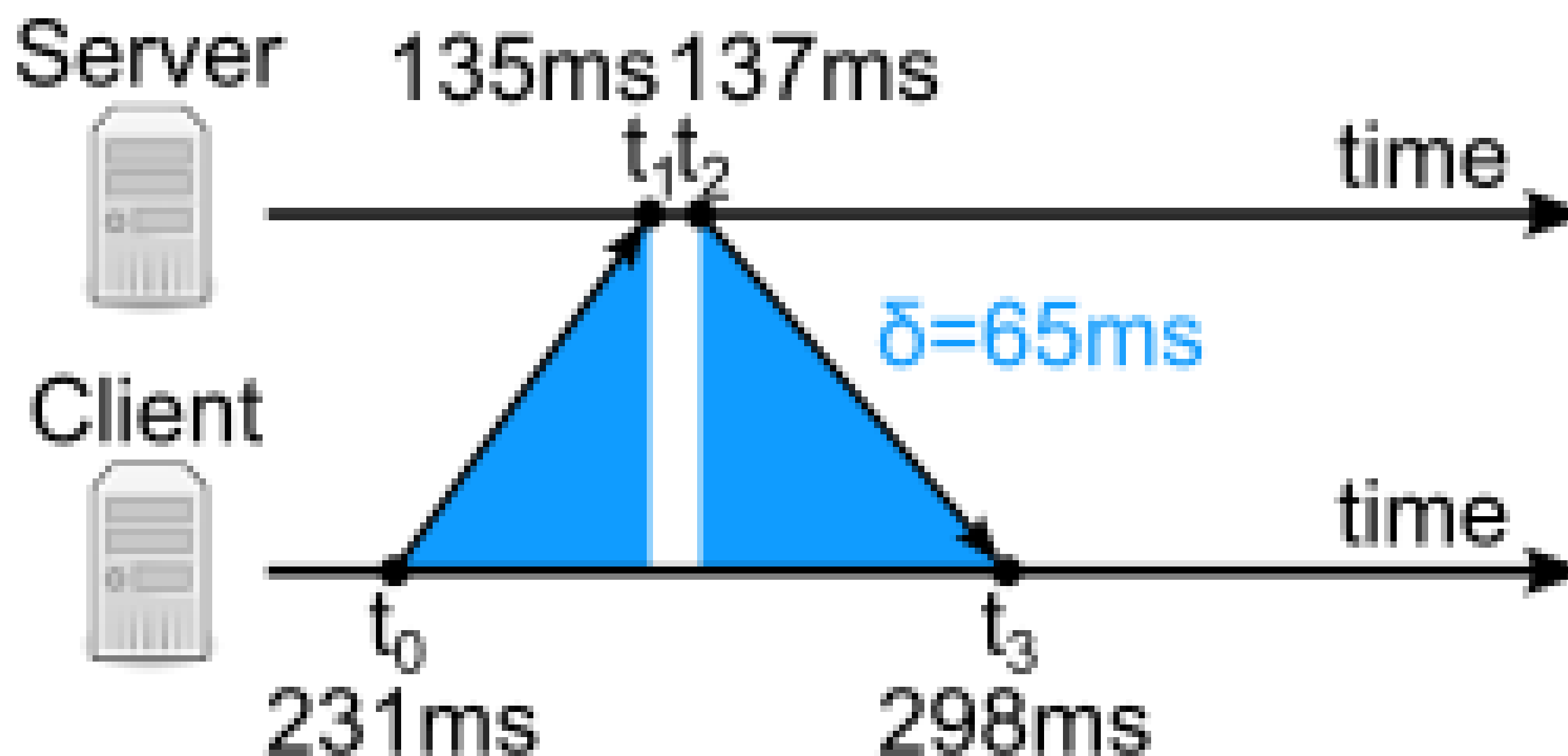

# PTP Protocol

- “Sub-Microsecond Timing”
- Same timing calculation
  - But EVERY switch tracks their  $t_2 - t_1$  in the chain
- NTP-UG is a PTP server (20ns accuracy from surface)
- Must coordinate with IT

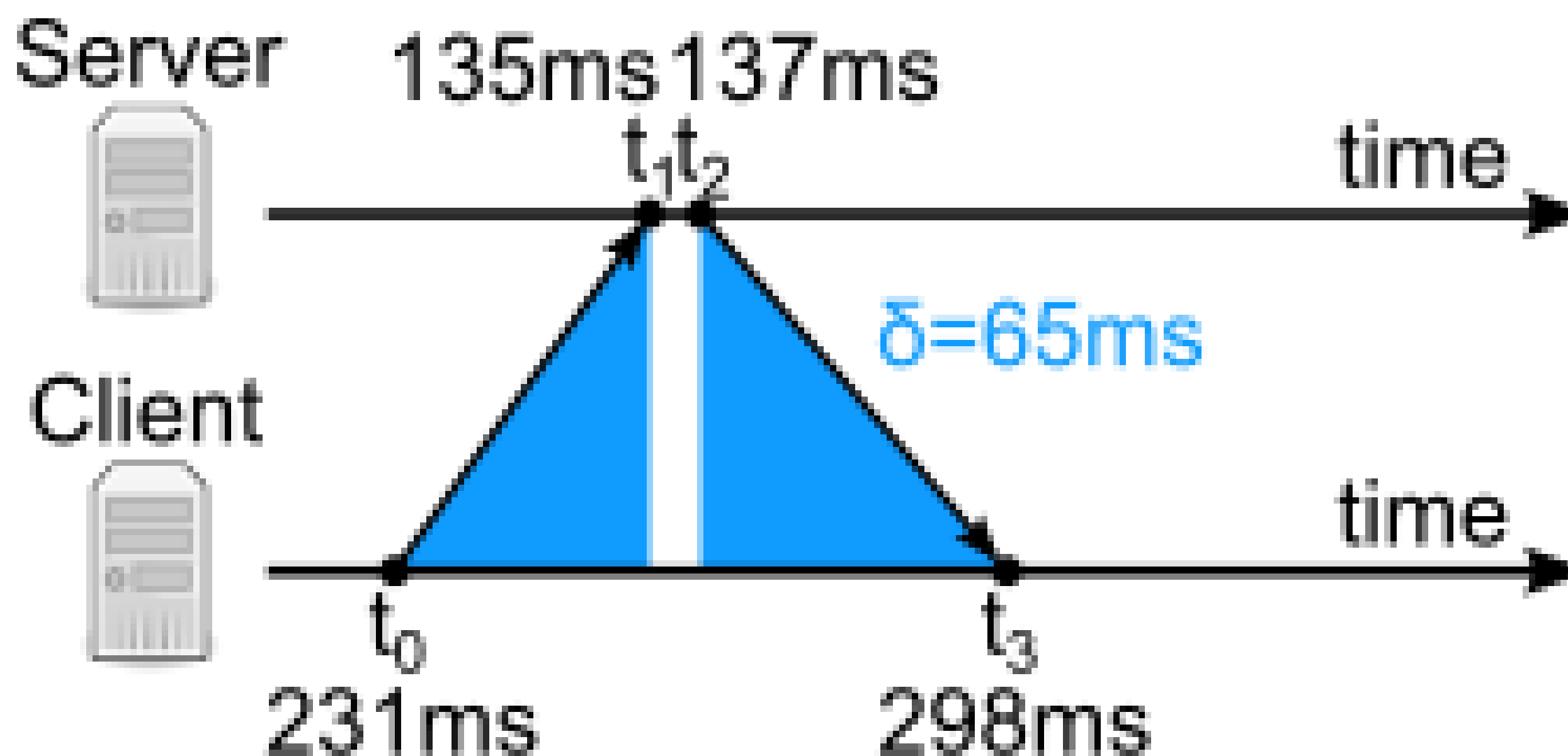

Seismometer near HALO  
1 Switch

Seismometer in LBL  
2 Switches

Offset from Master, nsec	28
One way delay, nsec	11264
HOPs (effective)	1.00

Offset from Master, nsec	15
One way delay, nsec	18992
HOPs (effective)	1.00

# Direct Connection

- 20 ns accuracy (1PPS, IRIG, other protocols available)
- Need a cable from CRU2 + receiver
- You are responsible for travel time correction

3 ns Offset

14 ns Standard Deviation

Average Time Delay:  $20.647 \pm 0.00063 \mu\text{s}$  StdDev:  $0.01375 \mu\text{s}$

Programmed Offset = 20.65 us

