

DORY

An Optical Monitoring and Calibration Module for the nEXO Outer Detector

Samin Majidi

PhD Candidate & CINP Graduate Fellow
McGill University & SNOLAB

Supervisors

Thomas Brunner & Erica Caden



A Fundamental Question

Why Are We Here?

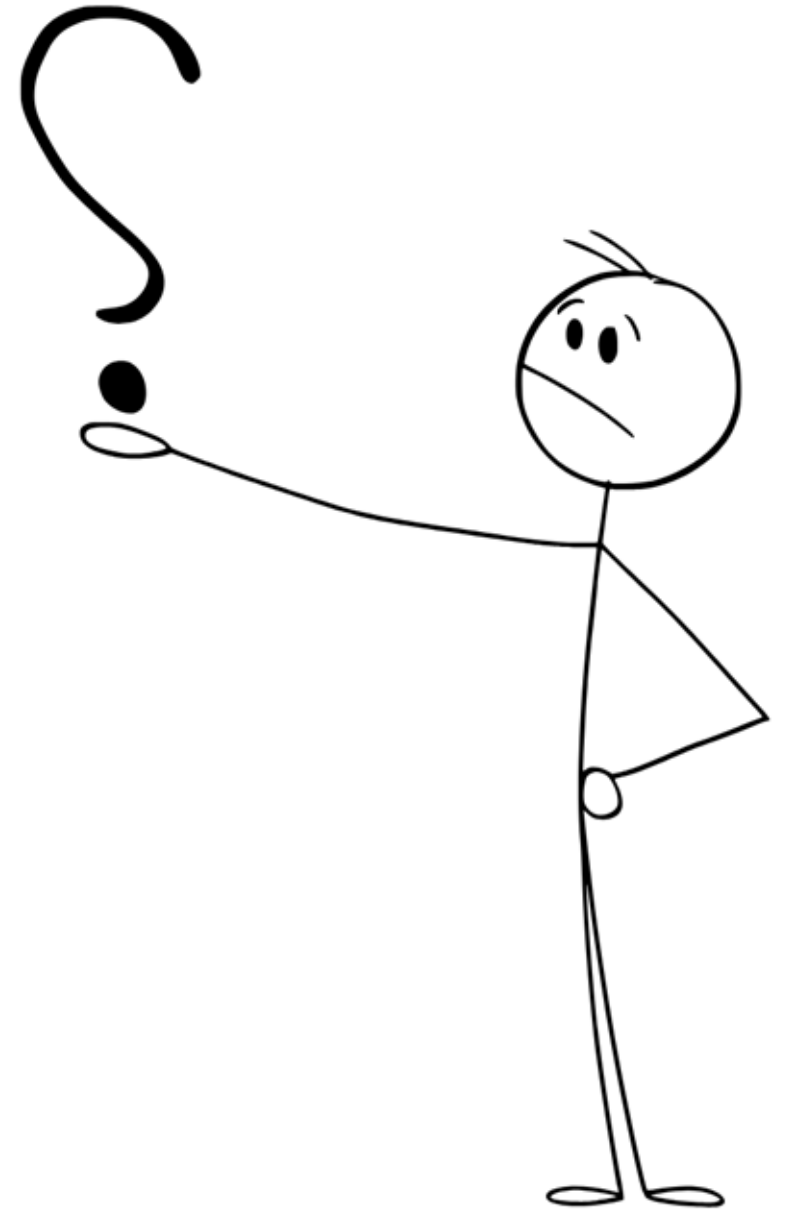

A Fundamental Question: Why Are We Here?

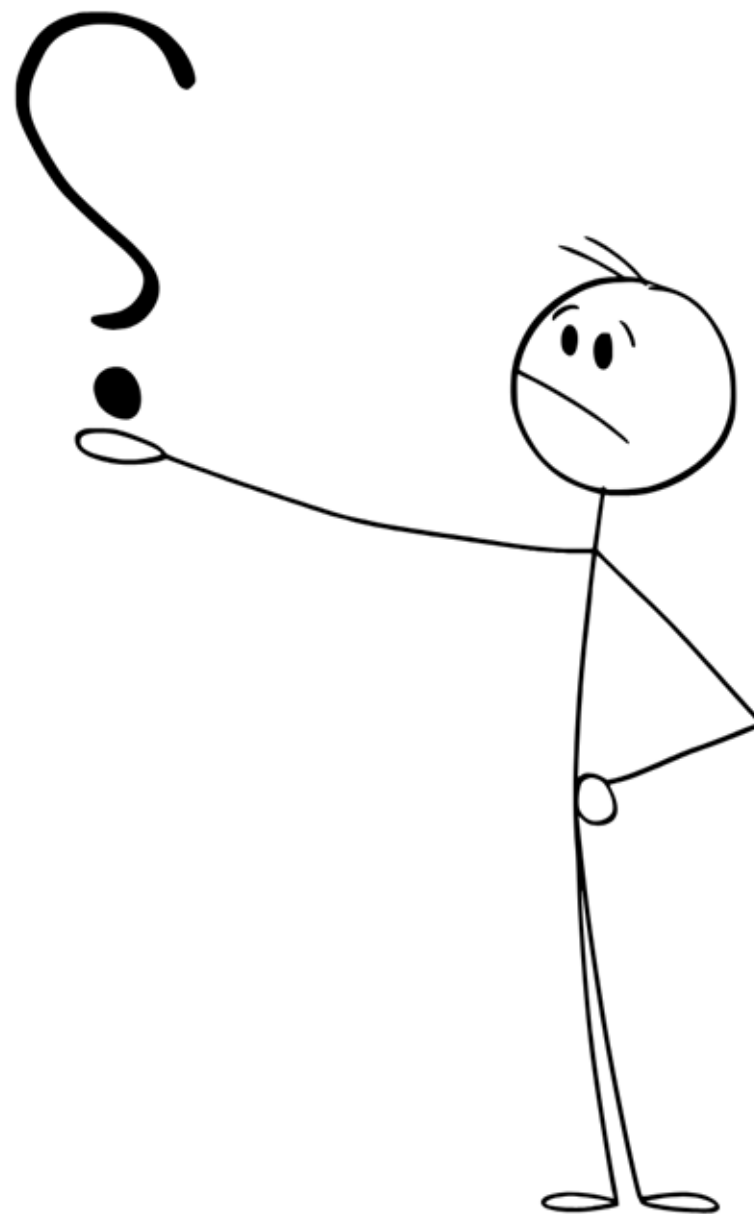

A Fundamental Question: Why Are We Here?



We are here
for the
SNOLAB User
Meeting.

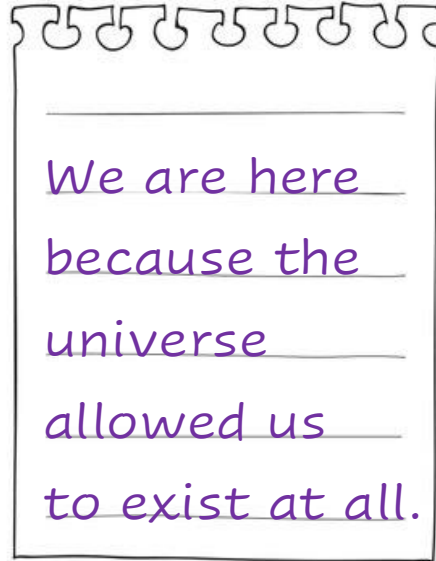

We are here
because the
universe
allowed us
to exist at all.

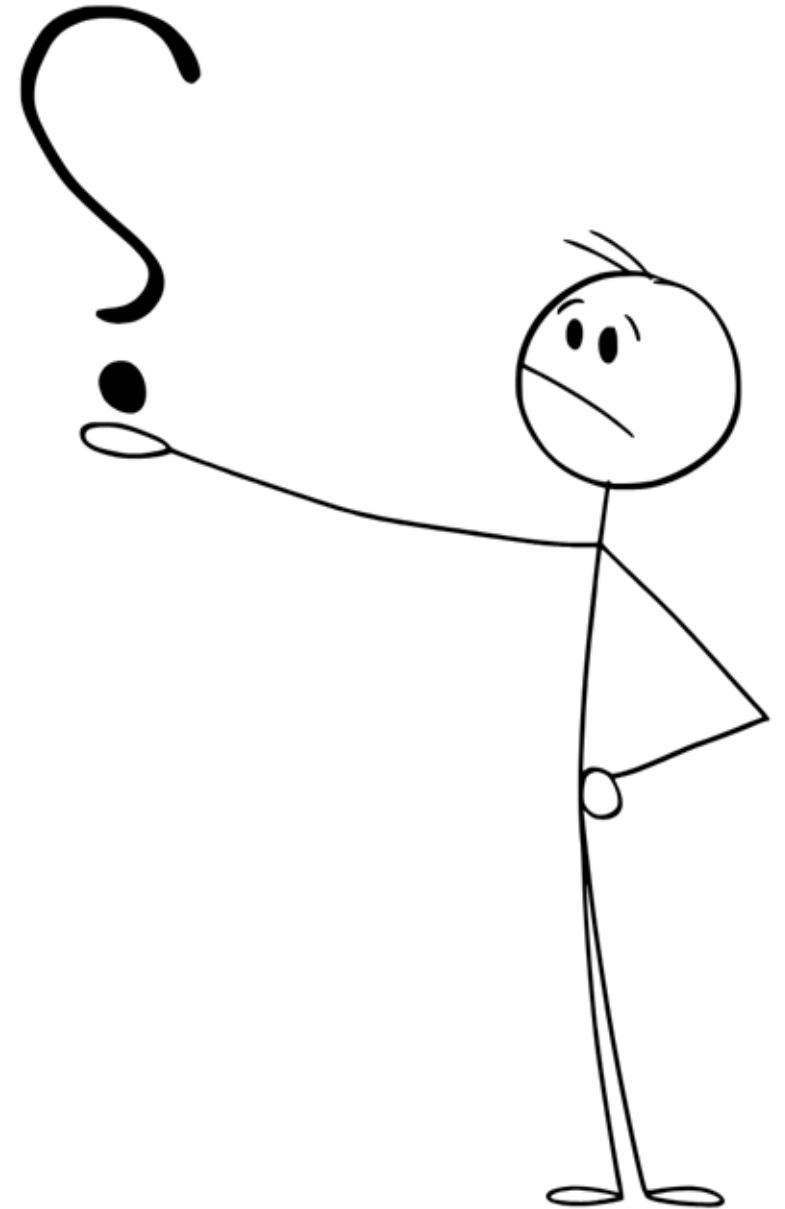

A Fundamental Question: Why Are We Here?



We are here
for the
SNOLAB User
Meeting.

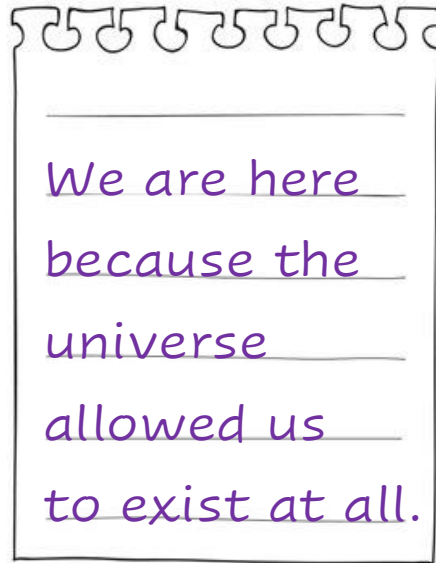

We are here
because the
universe
allowed us
to exist at all.

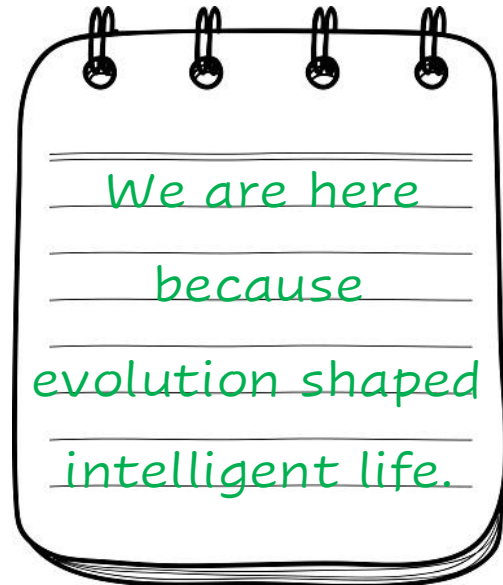

We are here
because
evolution shaped
intelligent life.

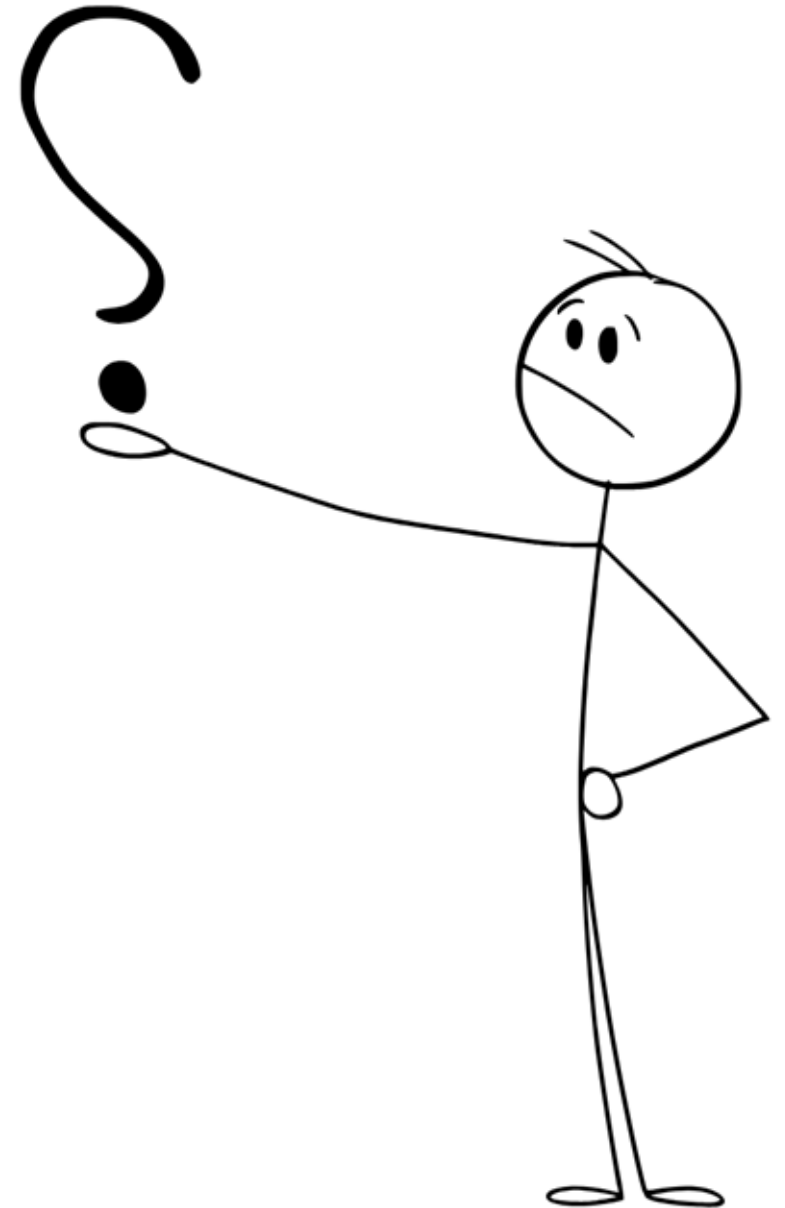

A Fundamental Question: Why Are We Here?



We are here
for the
SNOLAB User
Meeting.

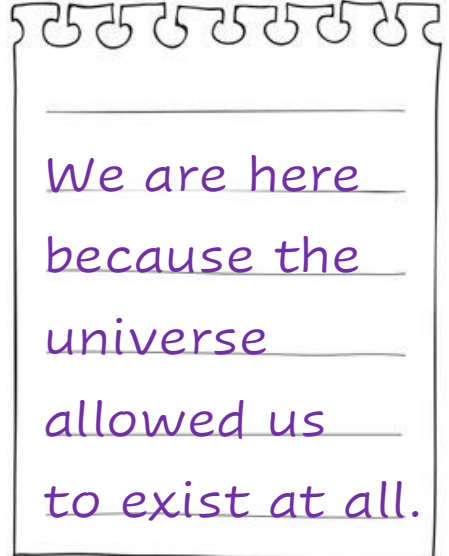

We are here
because the
universe
allowed us
to exist at all.



We are here
because
evolution shaped
intelligent life.



We are here
because, in the
early universe,
there was a
slight excess of
matter over
antimatter.

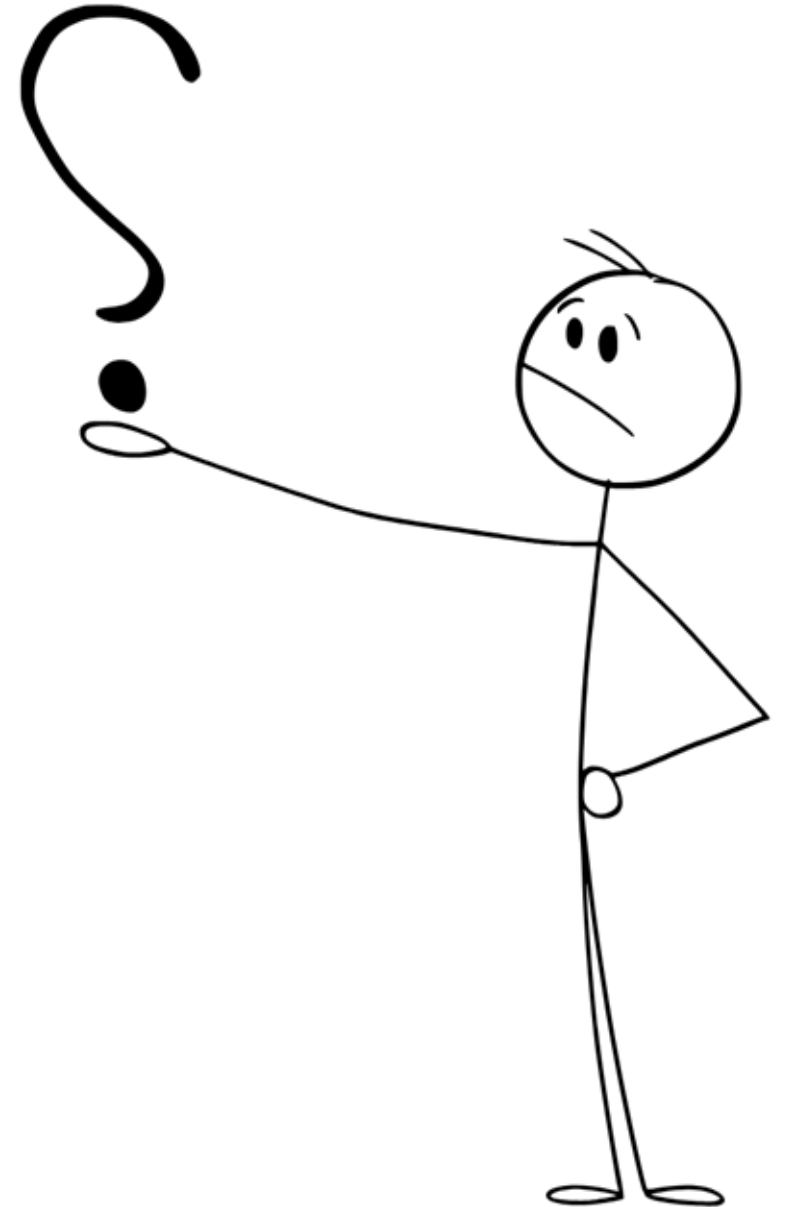

Matter-Antimatter Asymmetry

Based on the current ratio of photons to baryons, there were on the order of 10,000,000,001 matter particles for every 10,000,000,000 antimatter particles.

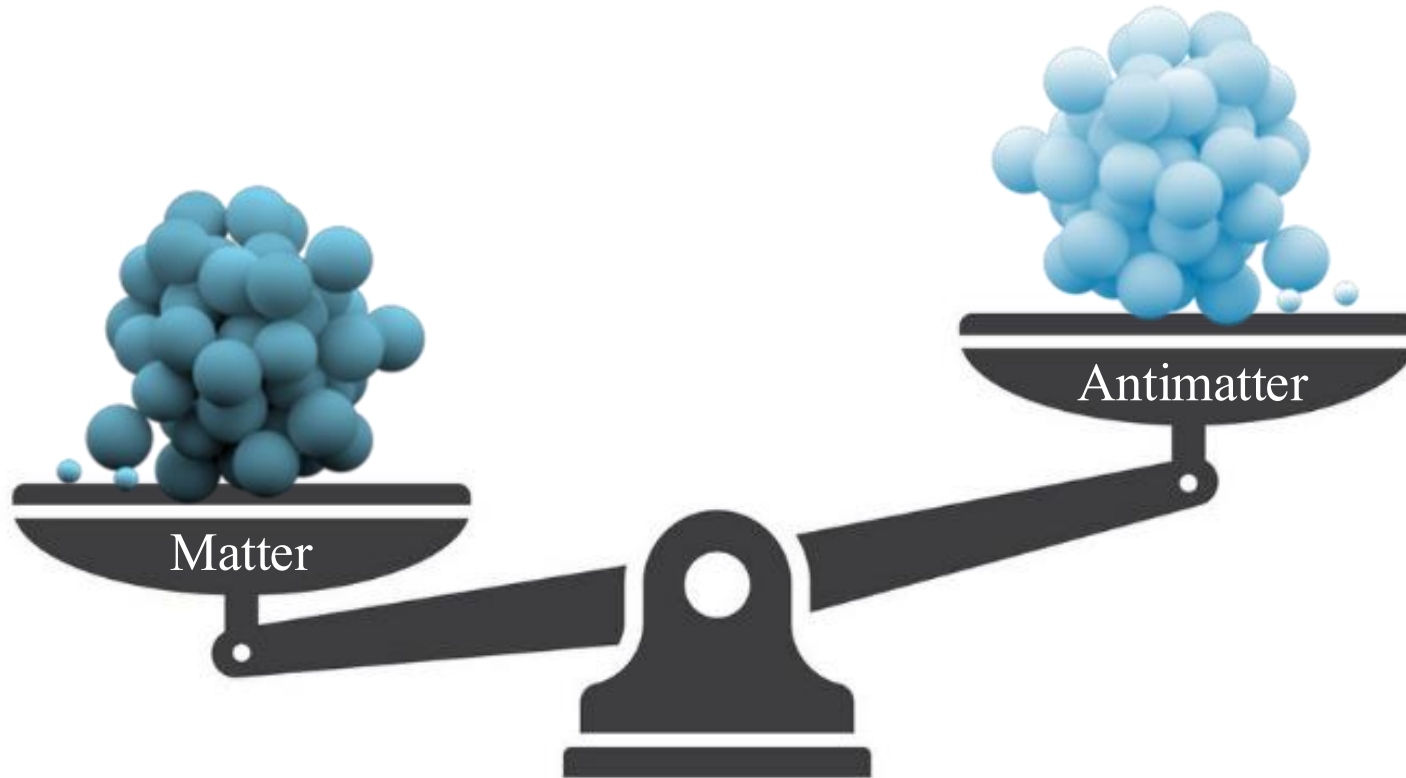

The fact that we have more matter in the universe, the Matter-Antimatter Asymmetry, is a problem in physics that has not been solved.

Leptogenesis and Majorana Neutrinos

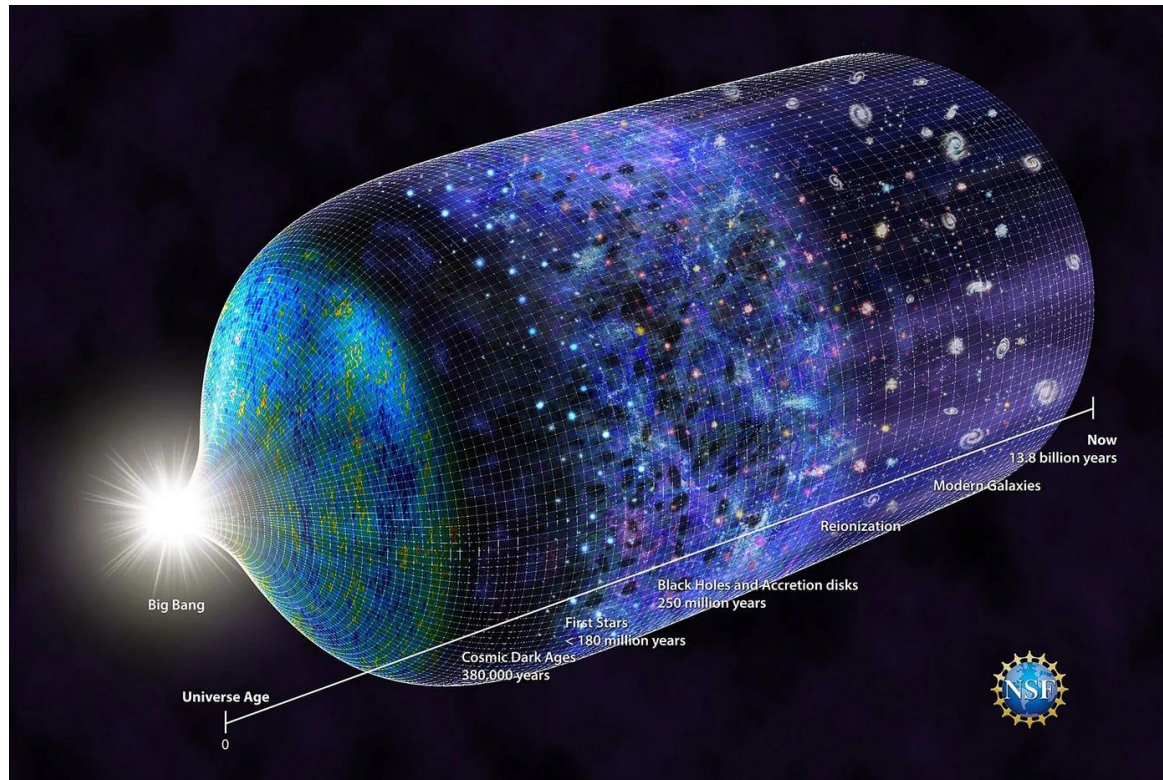

[Credit: Nicole Rager Fuller, National Science Foundation]

Leptogenesis is an explanation for the matter–antimatter asymmetry.

Early Universe

- excess of leptons over antileptons
- converted into baryon asymmetry (matter today)

Leptogenesis and Majorana Neutrinos

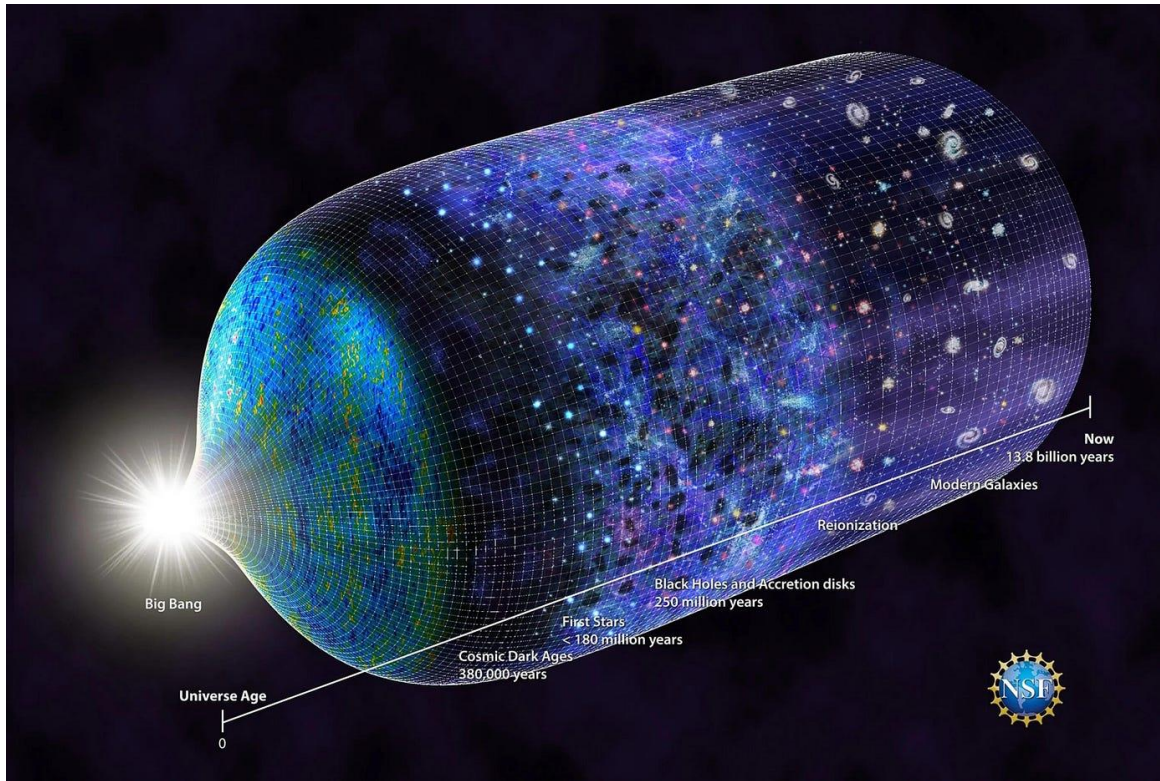

[Credit: Nicole Rager Fuller, National Science Foundation]

Leptogenesis is an explanation for the matter–antimatter asymmetry.

Early Universe

- excess of leptons over antileptons
- converted into baryon asymmetry (matter today)

In leptogenesis, neutrinos are assumed to be **Majorana particles** (meaning they are their own antiparticles).

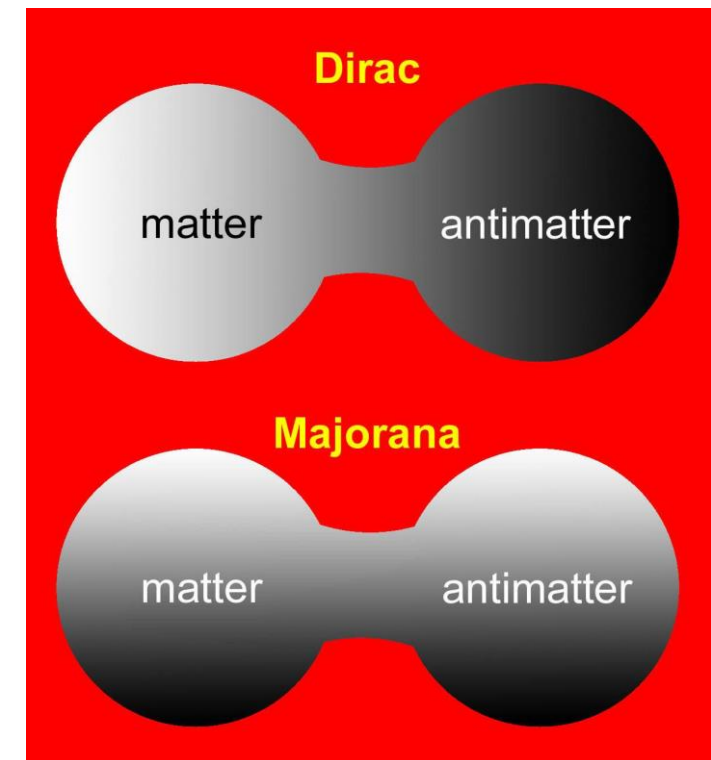

Neutrinoless Double Beta Decay

$2\nu\beta\beta$

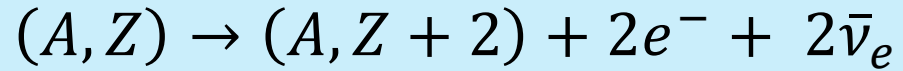

$0\nu\beta\beta$

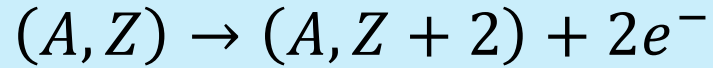

Neutrinoless double beta decay ($0\nu\beta\beta$) is forbidden in the Standard Model as it violates lepton number conservation in weak interactions.

A positive observation of $0\nu\beta\beta$ would demonstrate that neutrinos are Majorana particles.

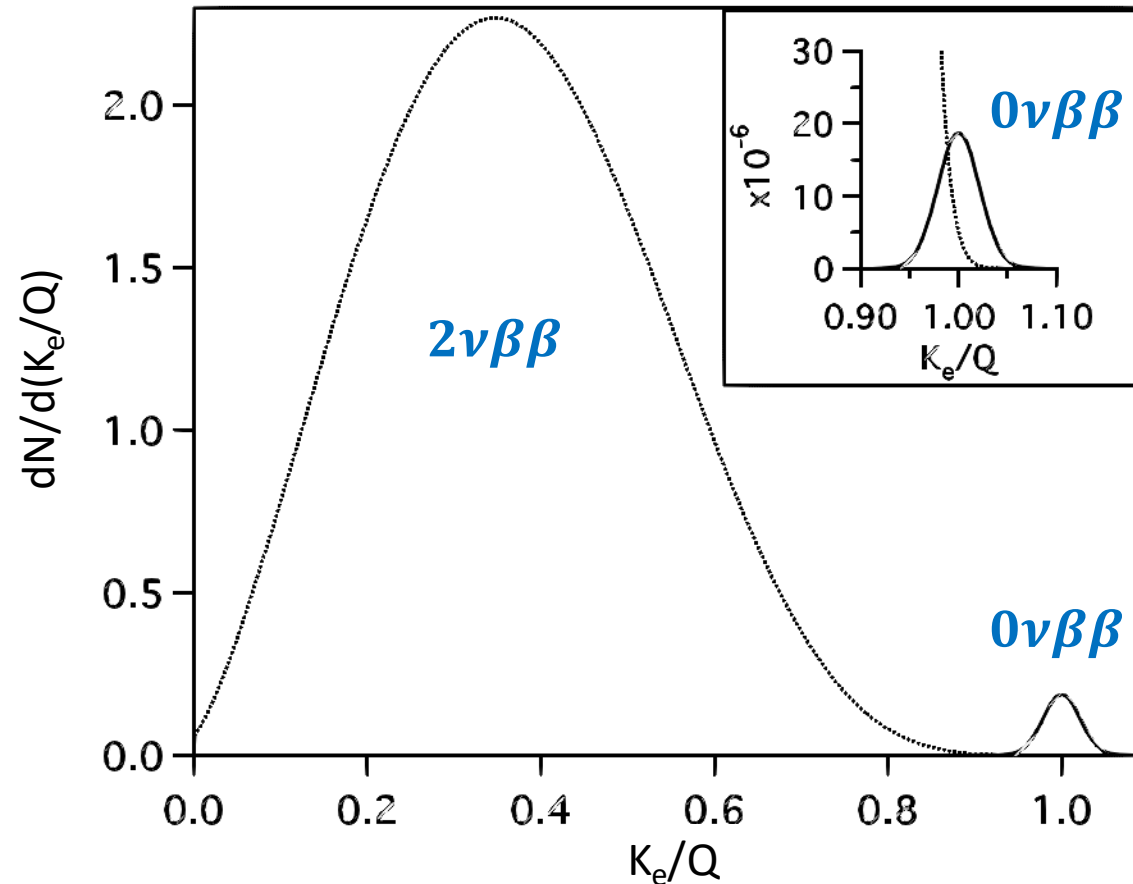

The nEXO Experiment

- nEXO is a proposed tonne-scale $0\nu\beta\beta$ search using ~ 5000 kg of ^{136}Xe .
- Liquid xenon (LXe) is housed in a cylindrical copper Time Projection Chamber (TPC).
- The TPC is submerged in HFE-7200 cryogenic fluid and housed inside a vacuum-insulated cryostat.
- The central detector is surrounded by the Outer Detector (OD), a water Cherenkov muon veto system.

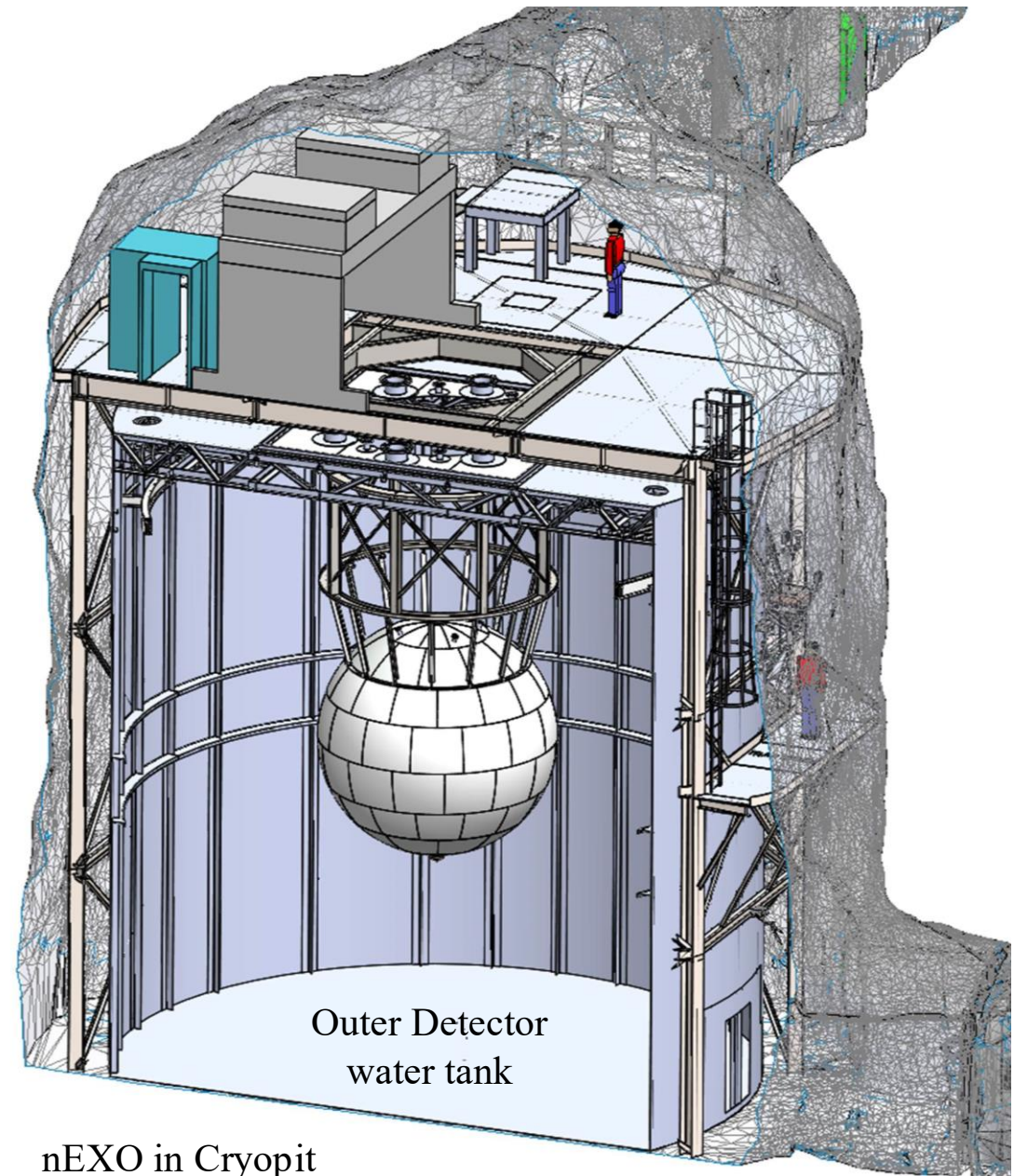
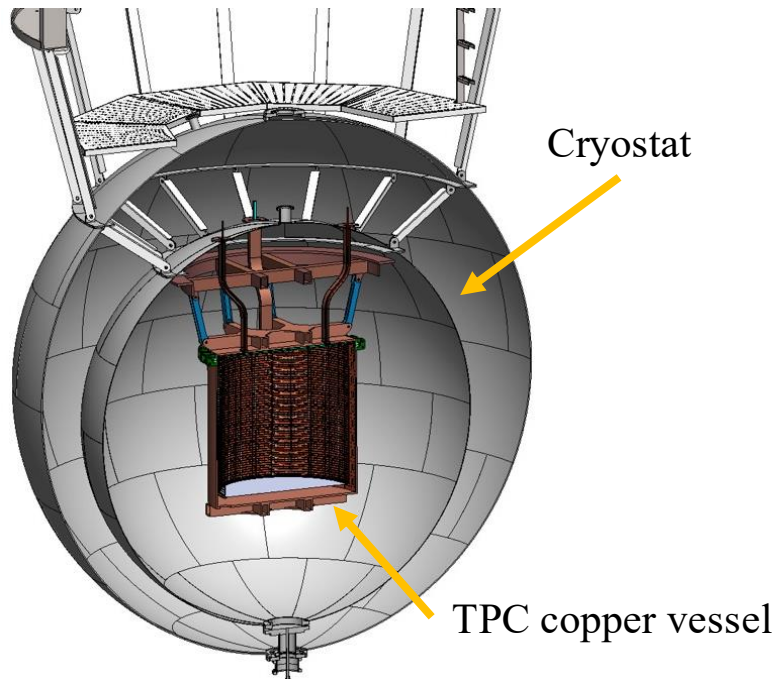

nEXO Outer Detector

Outer Detector is a:

- Water tank with a 12.3 meters diameter and 12.8 meters height.
- Contains 1.5 kilotonnes of ultra-pure water.
- Equipped with 125 Hamamatsu R5912 photomultiplier tubes (PMTs).

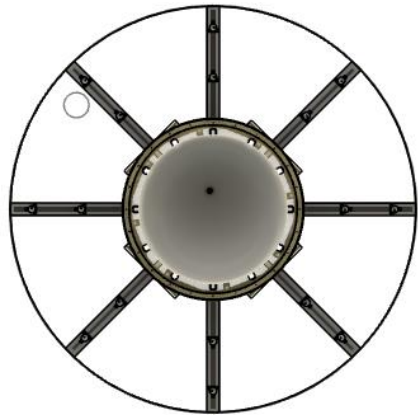

Top: 16 PMTs

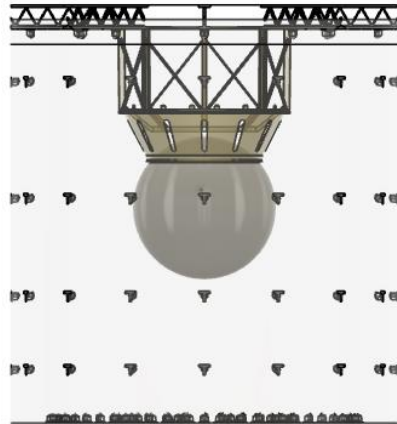

Side: 64 PMTs

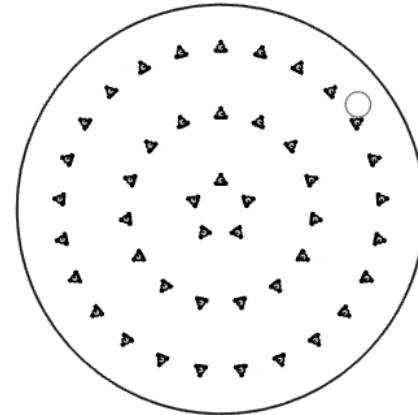

Bottom: 45 PMTs

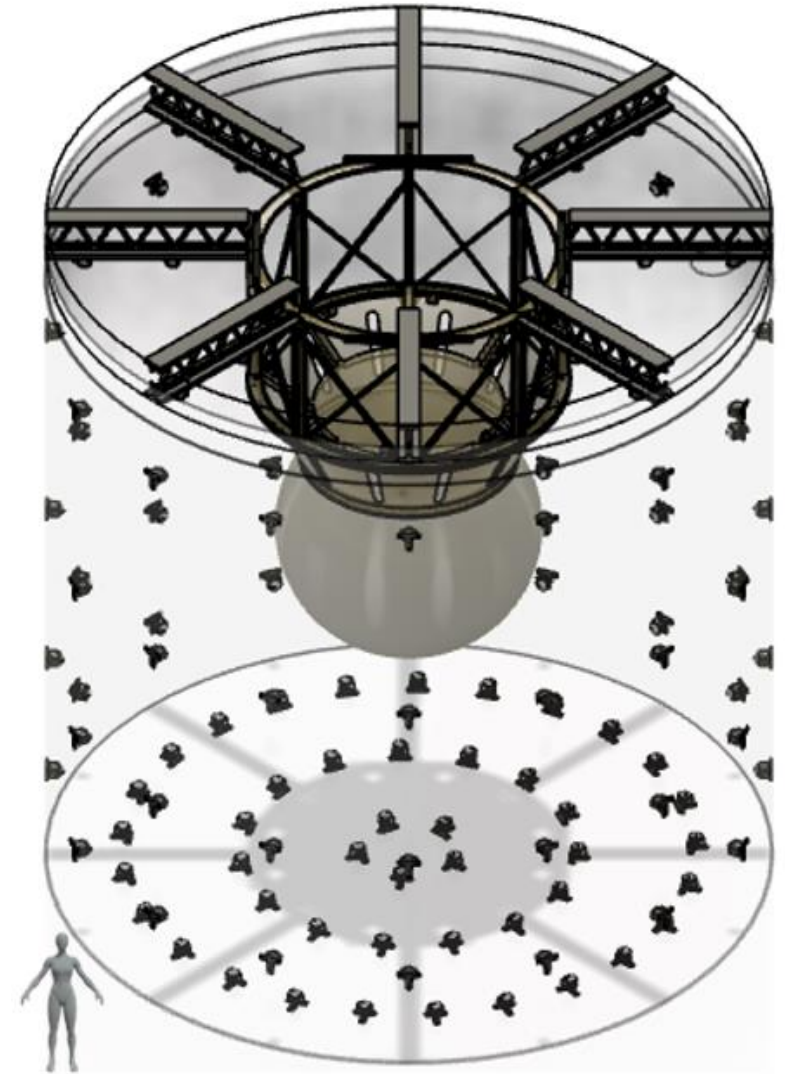

Outer Detector provides:

- Passive shielding – Reduces external gamma and neutron radiation entering the TPC.
- Active muon tagging – Detects muons through their Cherenkov light in water.

nEXO Outer Detector PMTs

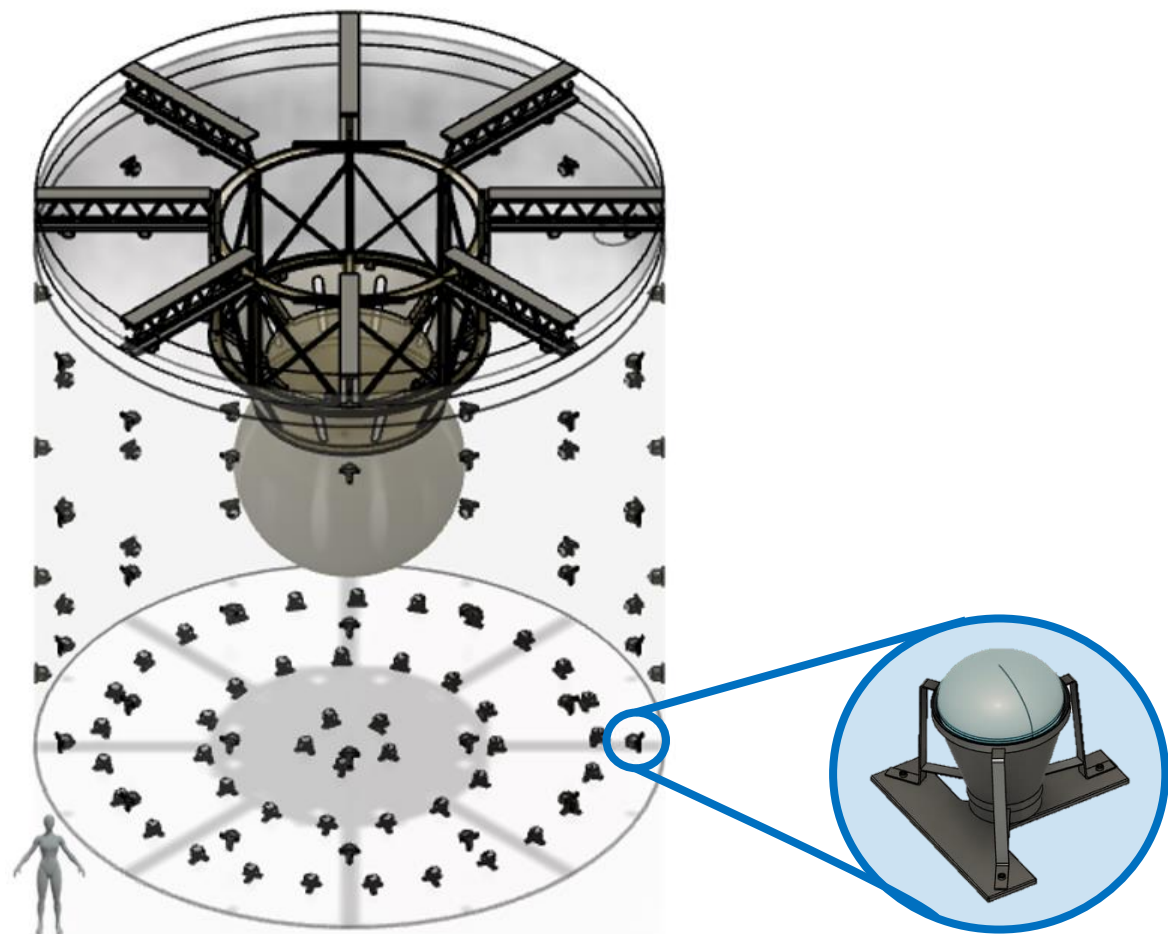

*Hamamatsu R5912 Photomultiplier Tube
from the Daya Bay Reactor Neutrino Experiment*
📍 PMT Testing Facility, Laurentian University, Canada
📷 Photo by Erica Caden



Water Cherenkov Muon Veto

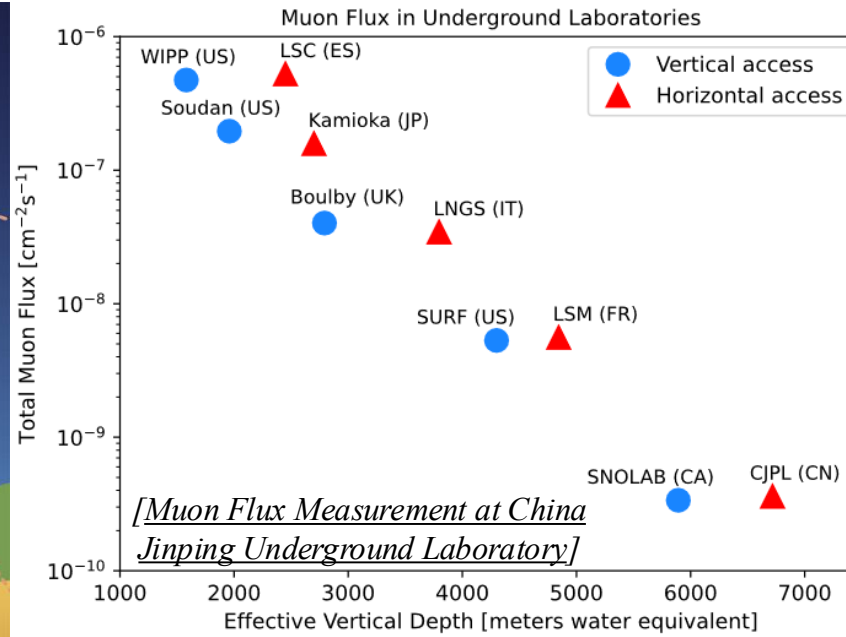
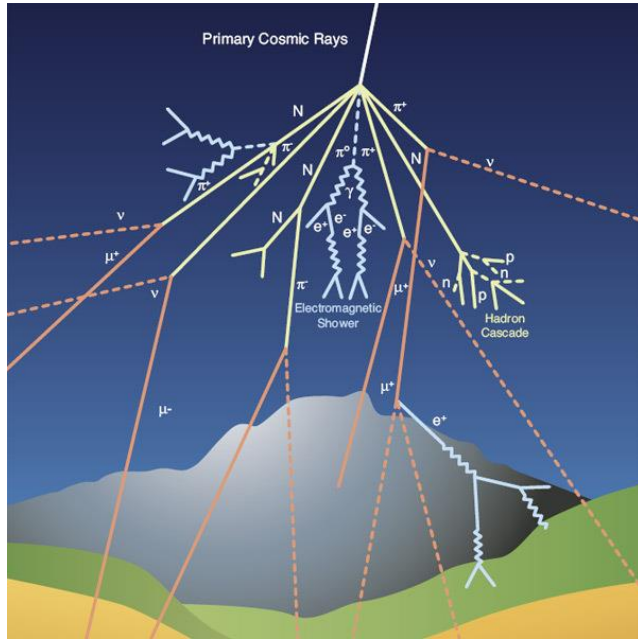

Water Cherenkov Muon Veto

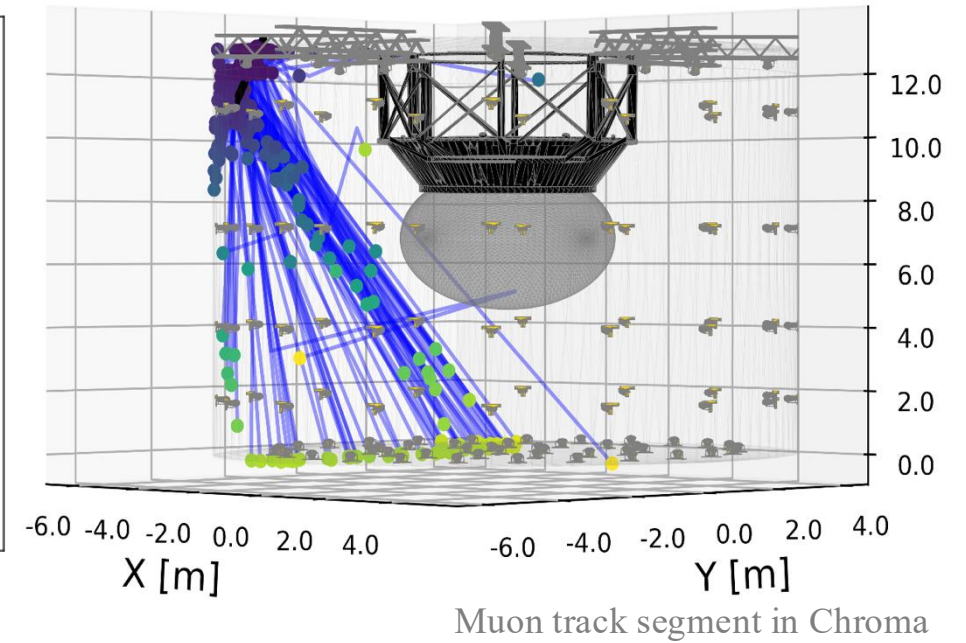
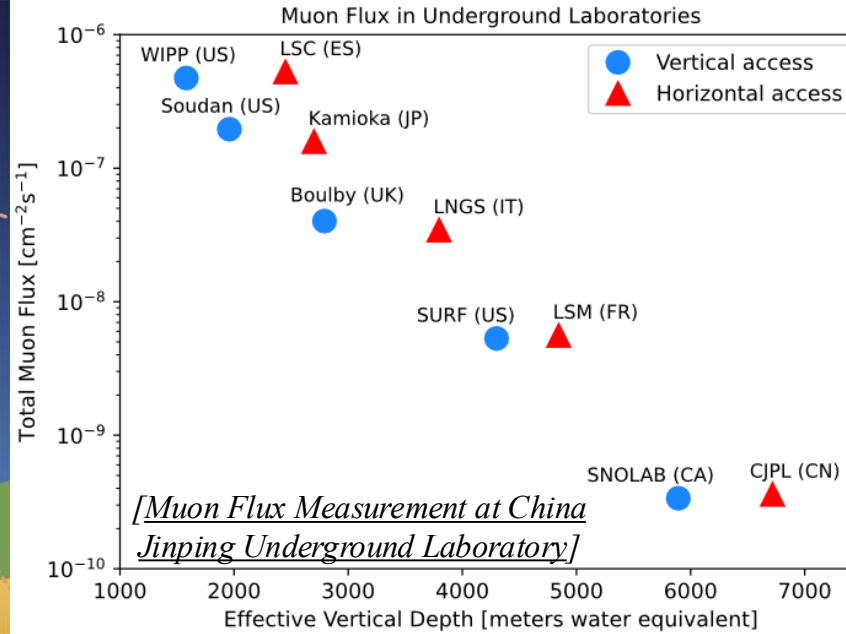
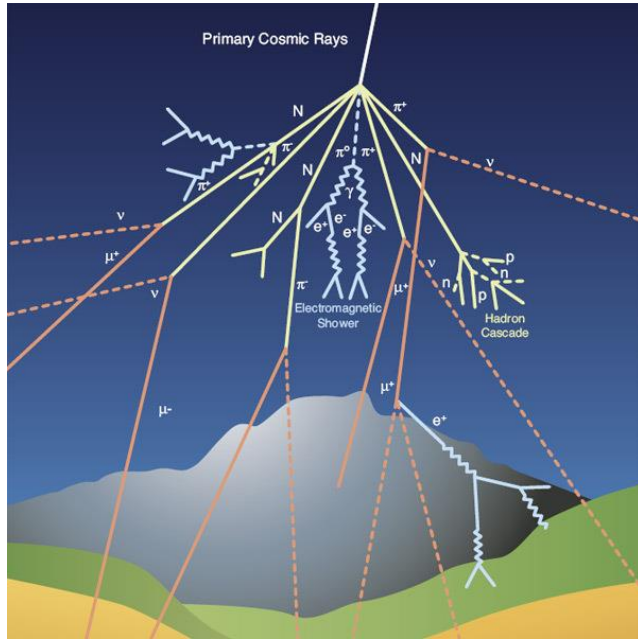

A muon passing through the water tank produces hundreds of neutrons

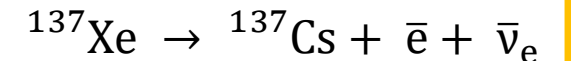
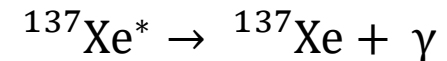
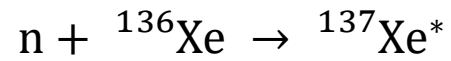

Water Cherenkov Muon Veto

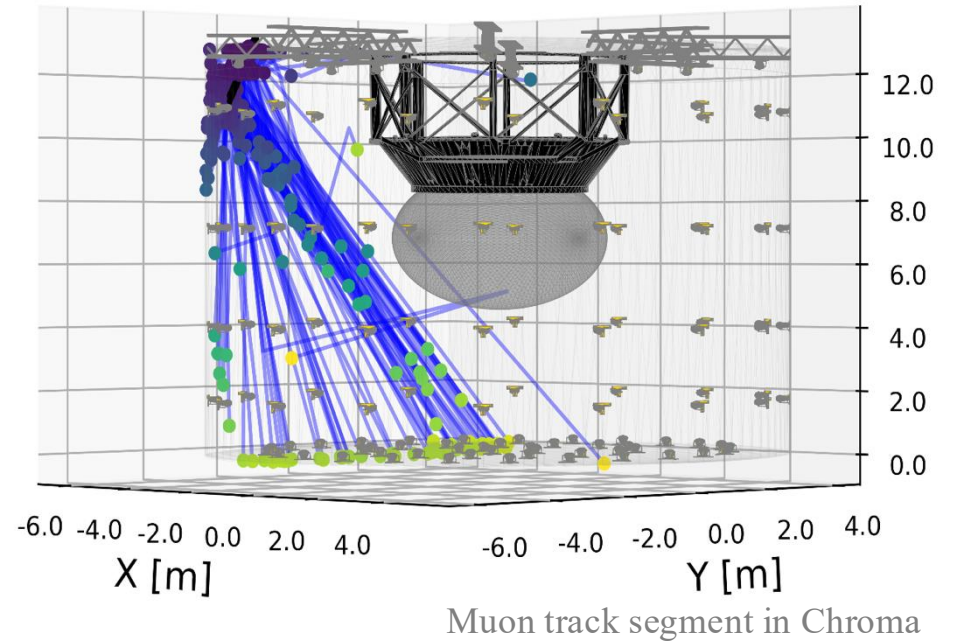
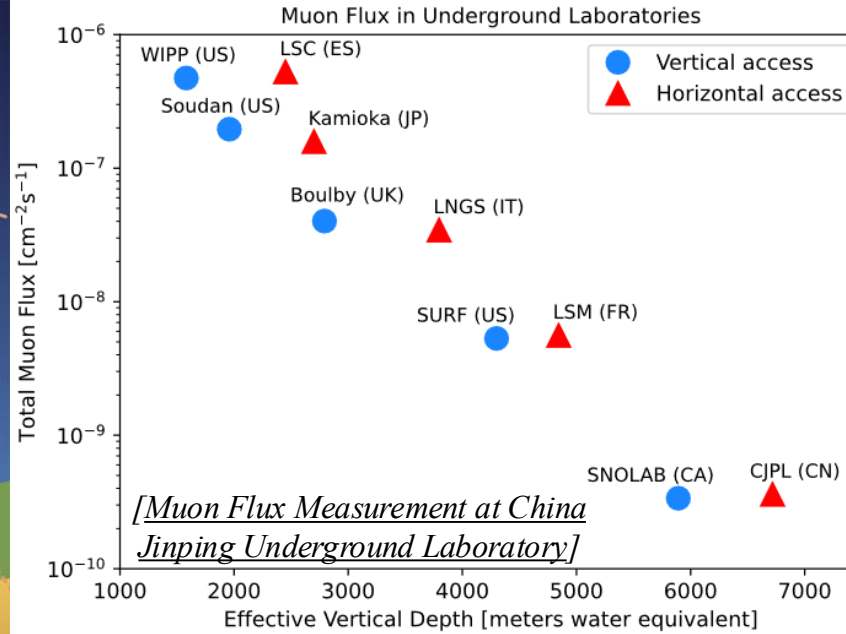
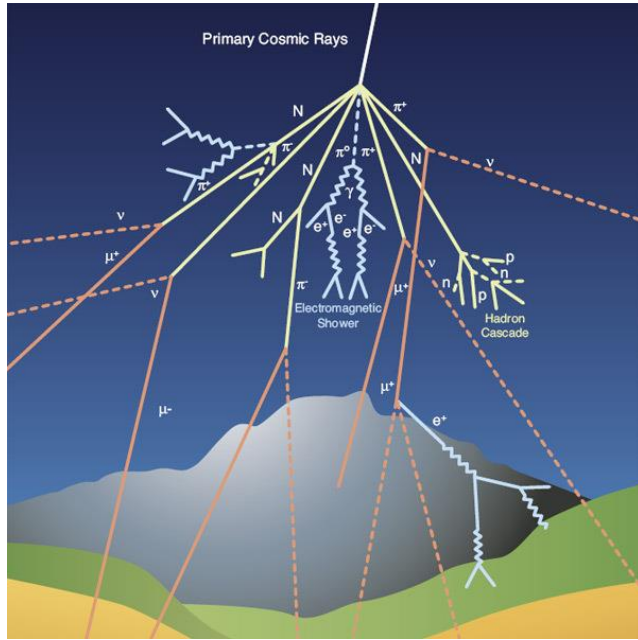

A muon passing through the water tank produces hundreds of neutrons

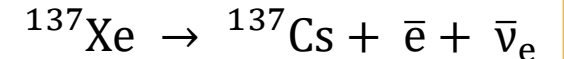
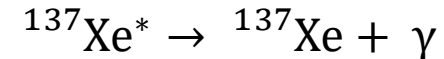

Tag muons via their Cherenkov emission in the water tank

Select ~ 10 milliseconds of TPC data

Search for gamma signatures from ${}^{136}\text{Xe}(n, \gamma){}^{137}\text{Xe}$

If gamma signatures are detected, veto the TPC readout for an additional number of half-lives of ${}^{137}\text{Xe}$

Outer Detector Monitoring & Calibration System

A calibration and monitoring system is being developed for OD;

- Purpose: To **calibrate the timing properties of the PMT readout system, monitor the optical properties and quality of the water**, and **track the performance of OD** throughout the lifetime of the experiment.
- System concept: **Laser-based fiber-optic setup** delivering light to optical modules (**DORY**) inside the water tank.

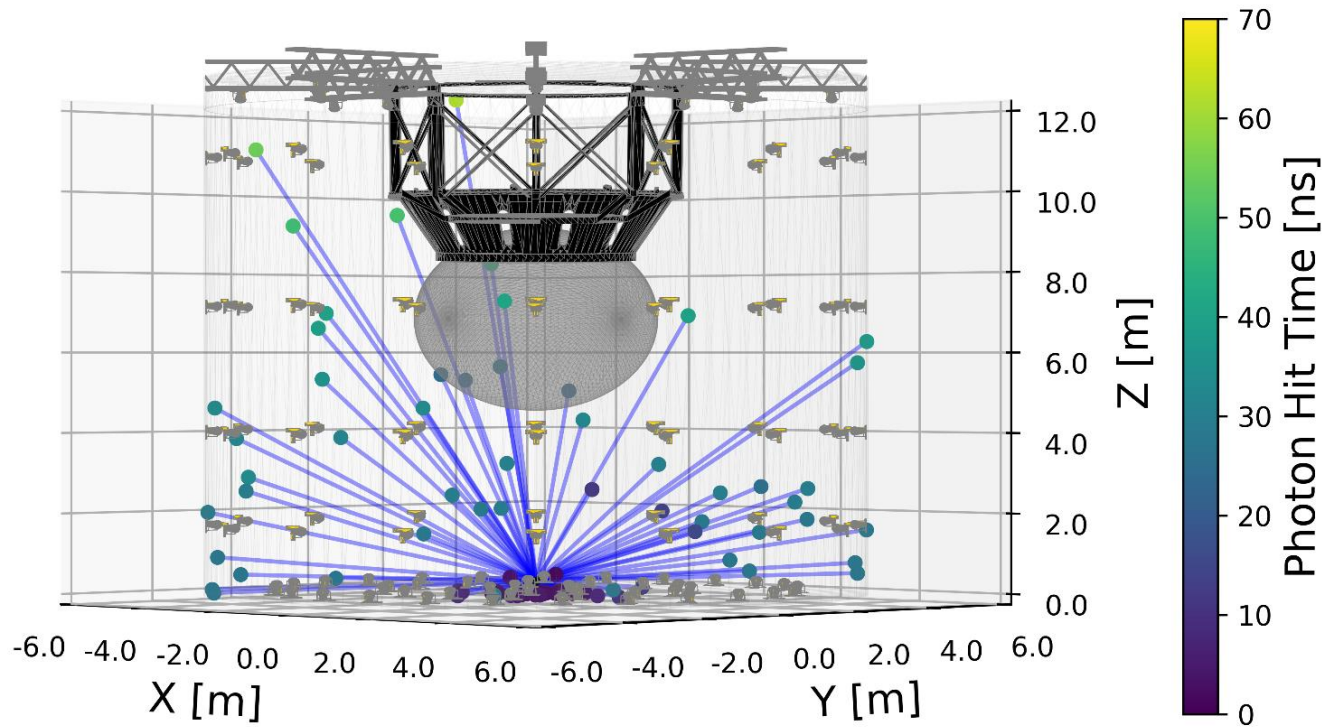

Simulation of a 390 nm point light source emitting isotropically across the OD.

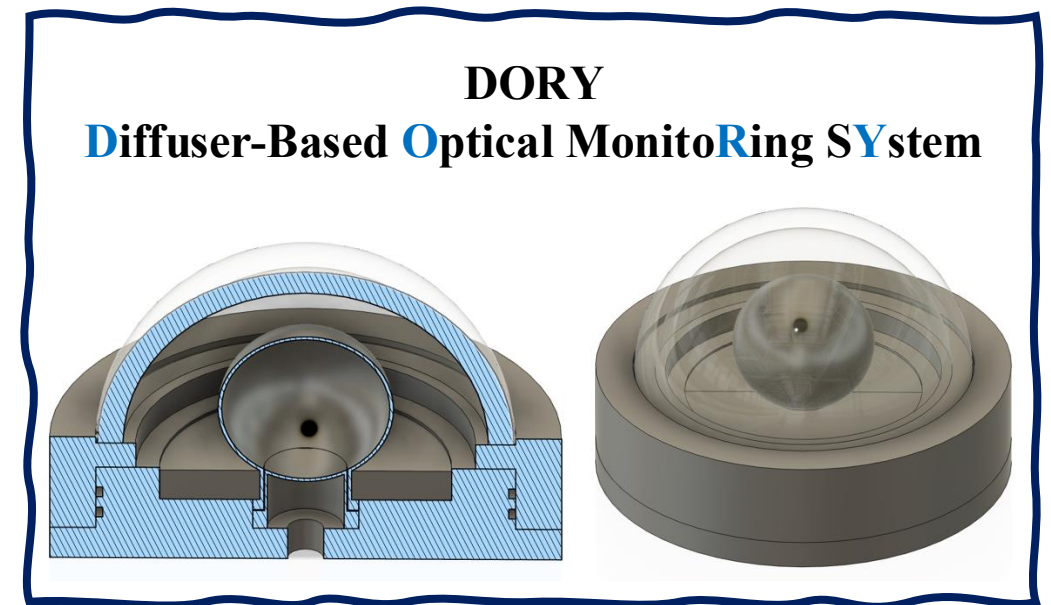

DORY: An Optical Module for Outer Detector Monitoring & Calibration

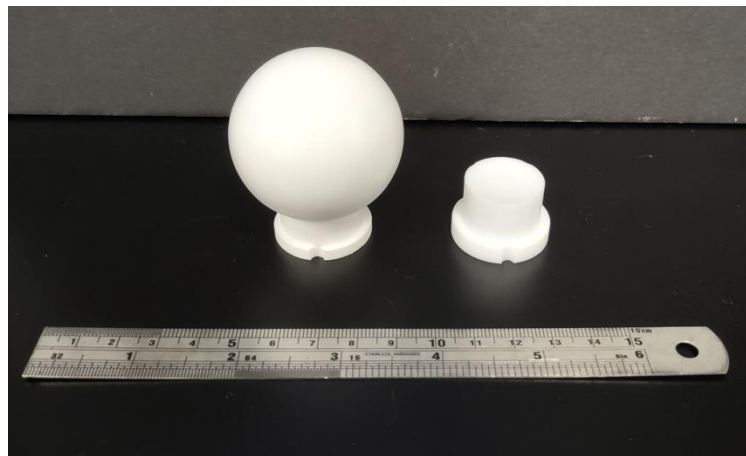

Optical Teflon (PTFE) plug and sphere

DORY: An Optical Module for Outer Detector Monitoring & Calibration

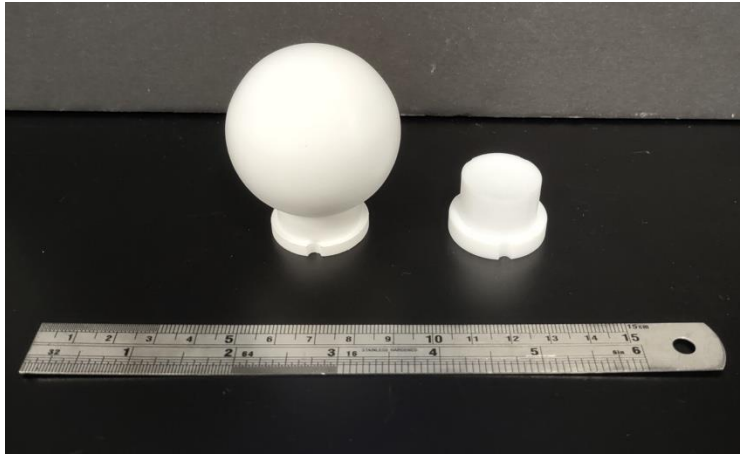

Optical Teflon (PTFE) plug and sphere



Assembly of the PTFE diffuser

[A self-monitoring precision calibration light source for large-volume neutrino telescopes]

DORY: An Optical Module for Outer Detector Monitoring & Calibration

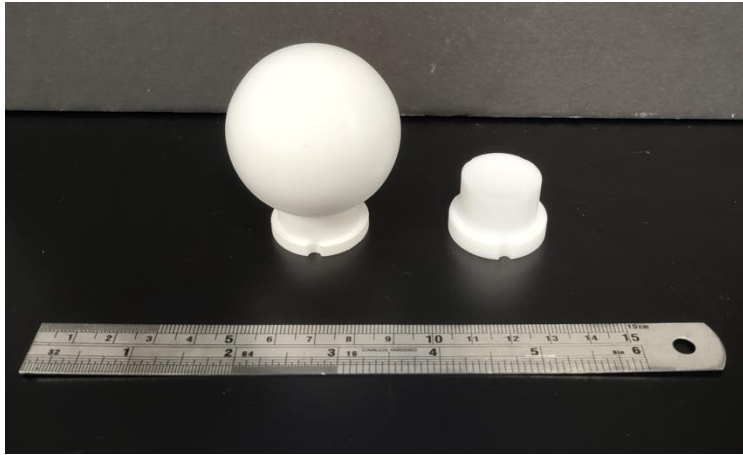

Optical Teflon (PTFE) plug and sphere



Assembly of the PTFE diffuser

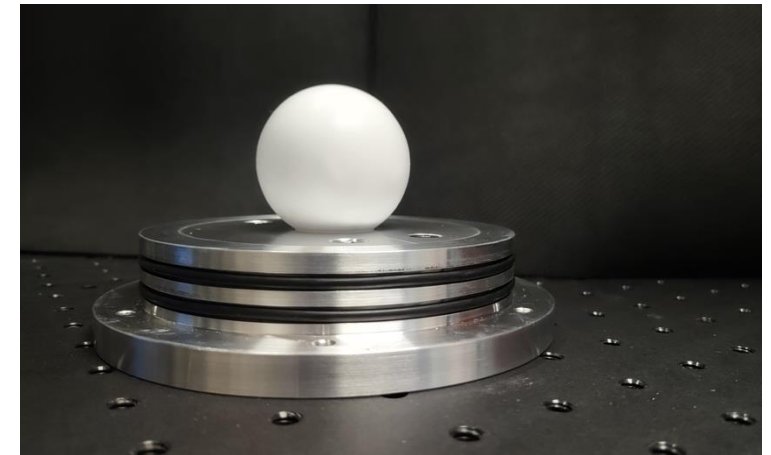

Diffuser assembly with aluminum components and O-rings

DORY: An Optical Module for Outer Detector Monitoring & Calibration

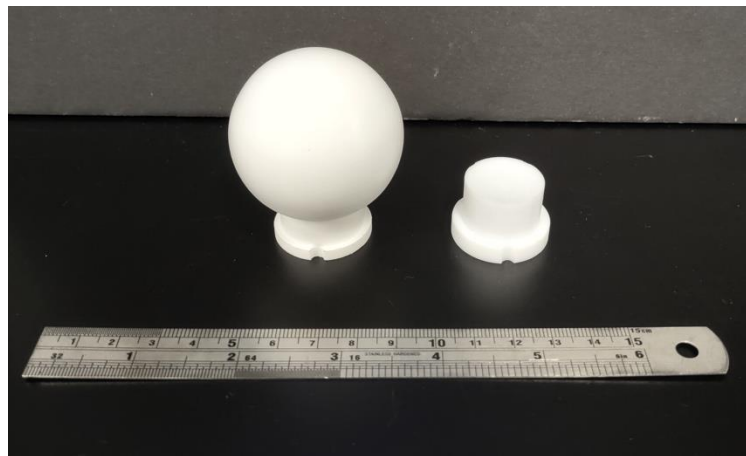

Optical Teflon (PTFE) plug and sphere



Assembly of the PTFE diffuser

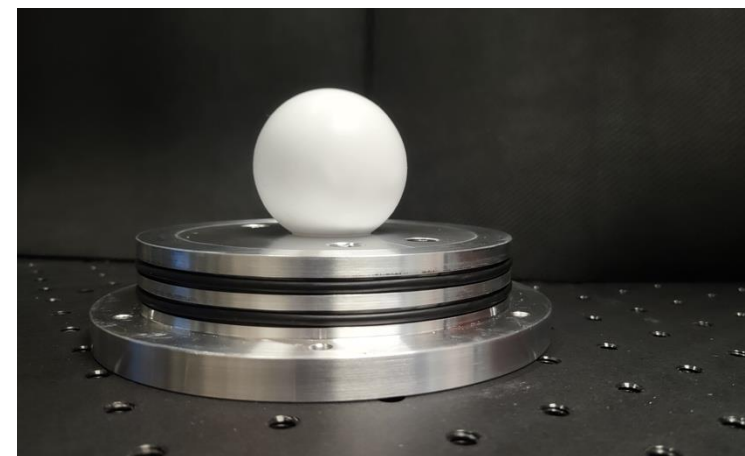

Diffuser assembly with aluminum components and O-rings

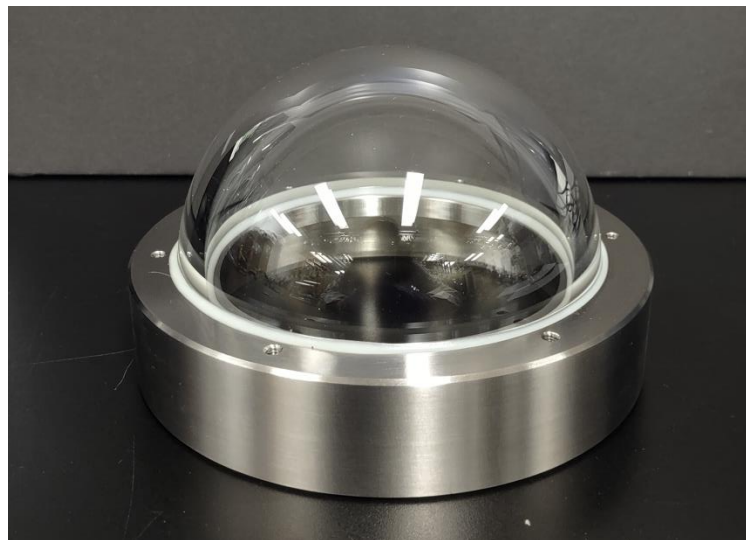

Pressure housing made of borosilicate (H-K9L) glass and titanium flange

DORY: An Optical Module for Outer Detector Monitoring & Calibration

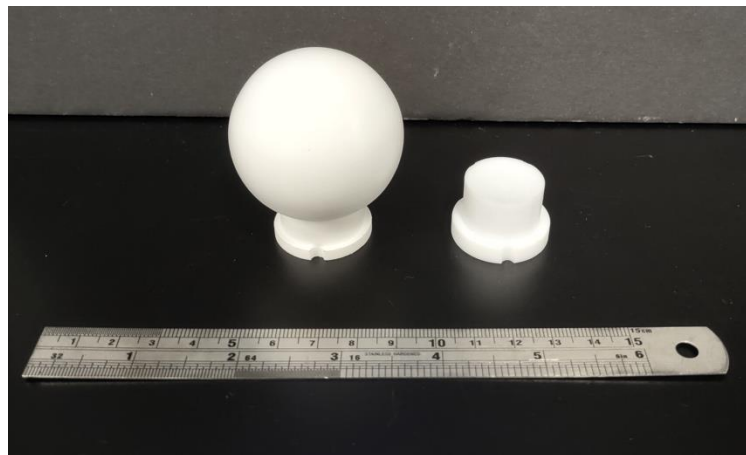

Optical Teflon (PTFE) plug and sphere



Assembly of the PTFE diffuser

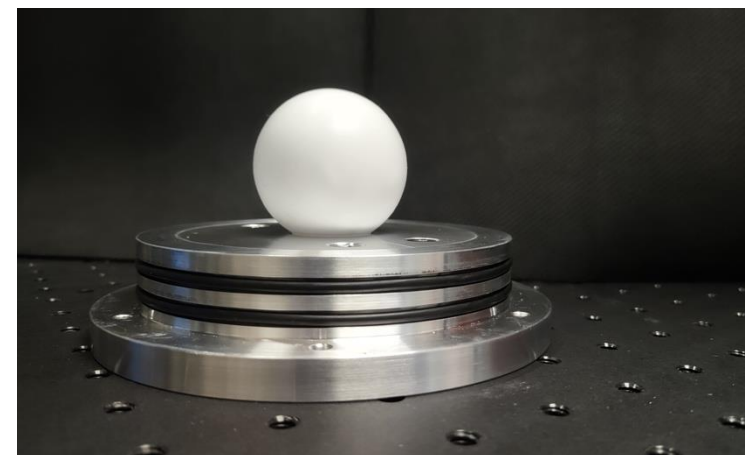

Diffuser assembly with aluminum components and O-rings

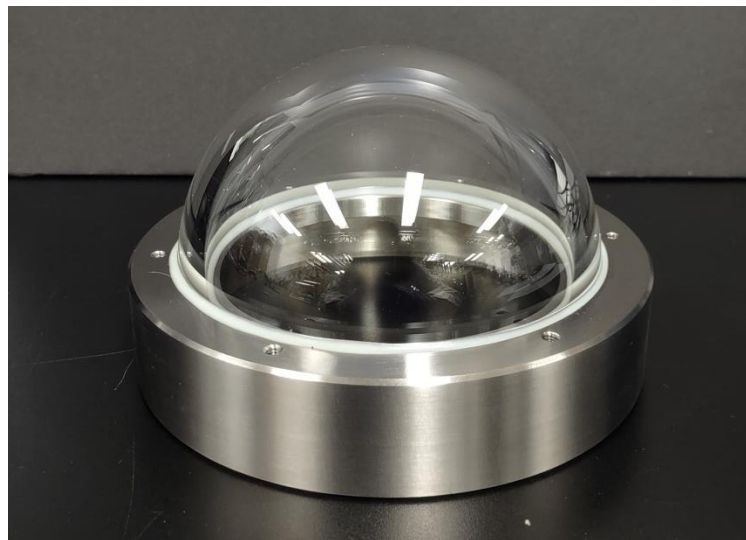

Pressure housing made of borosilicate (H-K9L) glass and titanium flange

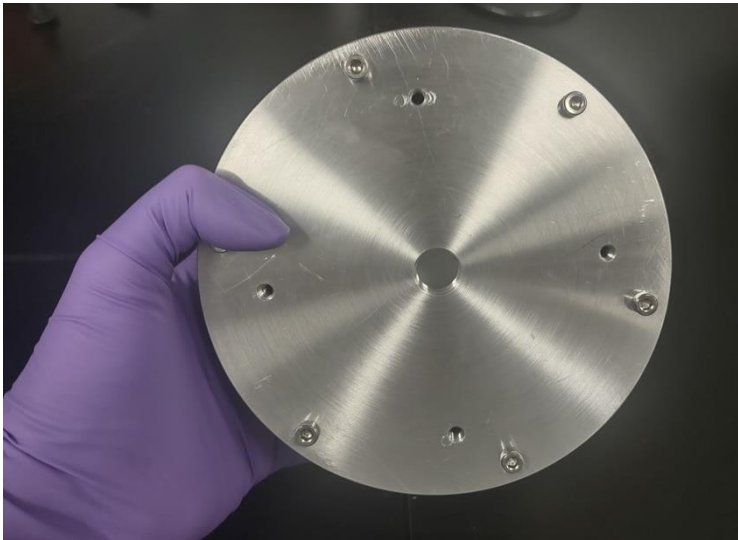

Back of DORY

DORY: An Optical Module for Outer Detector Monitoring & Calibration

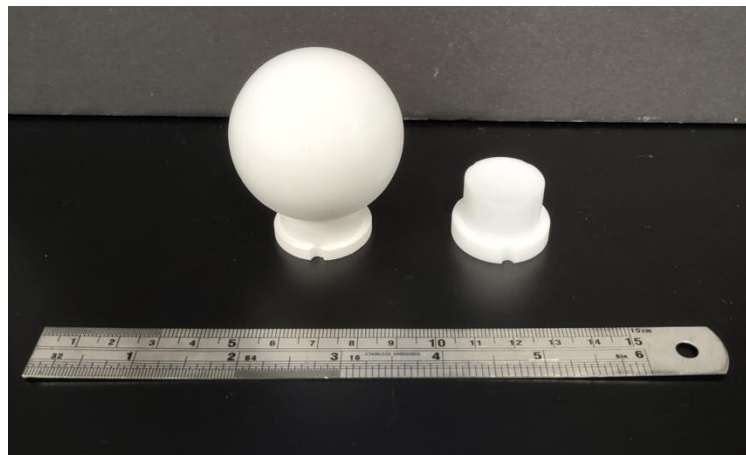

Optical Teflon (PTFE) plug and sphere



Assembly of the PTFE diffuser

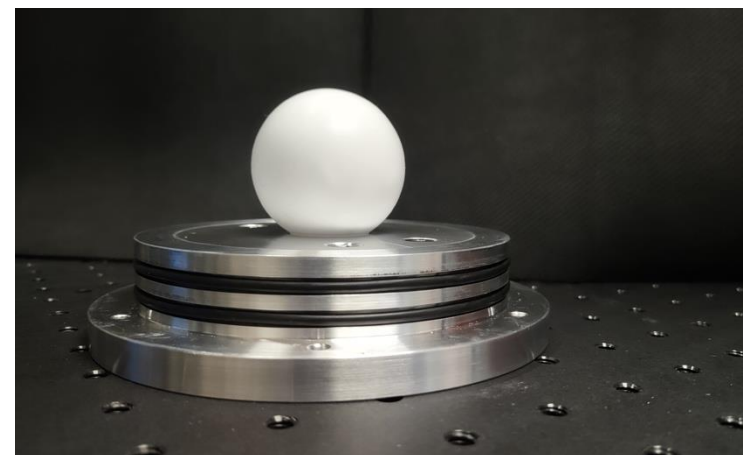

Diffuser assembly with aluminum components and O-rings

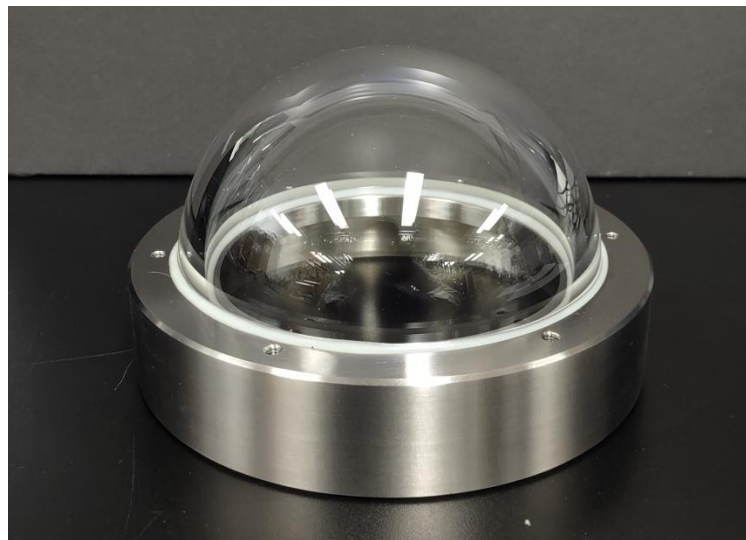

Pressure housing made of borosilicate (H-K9L) glass and titanium flange

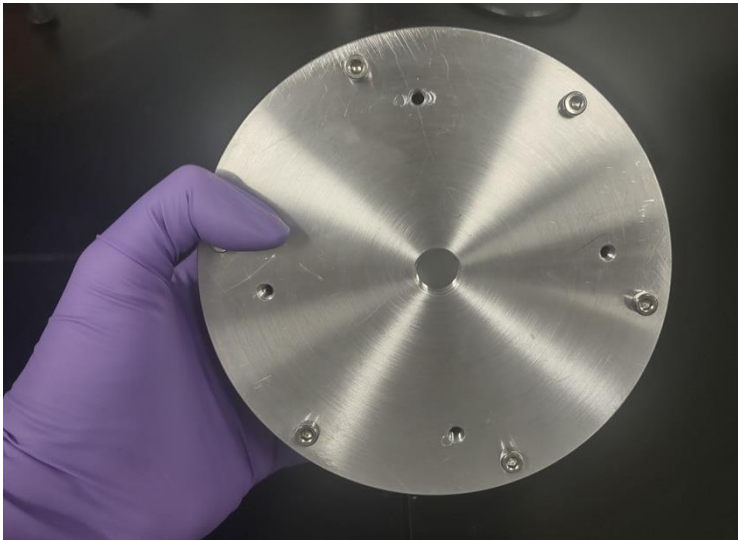

Back of DORY

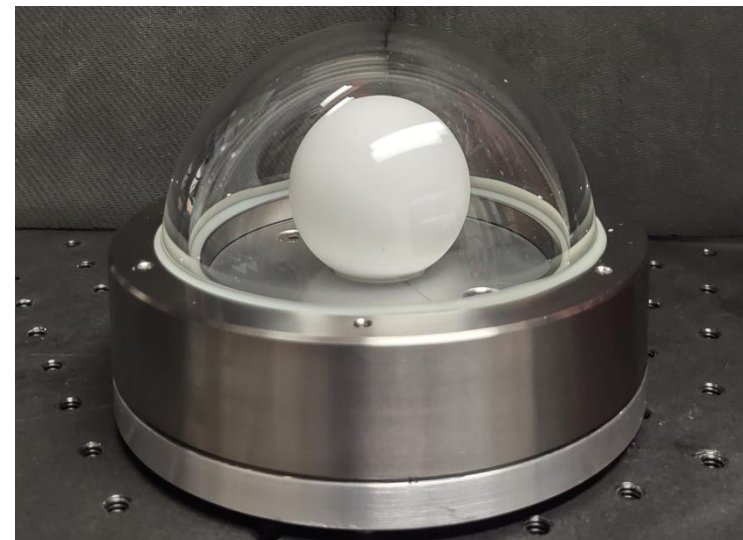

First DORY prototype

Chroma Simulations



Chroma is a GPU-accelerated optical photon Monte Carlo framework for particle physics detectors. Using ray tracing and triangulated detector geometries, it simulates optical processes while propagating millions of photons per second. Chroma performs $50\times$ faster than equivalent GEANT4 optical simulations.

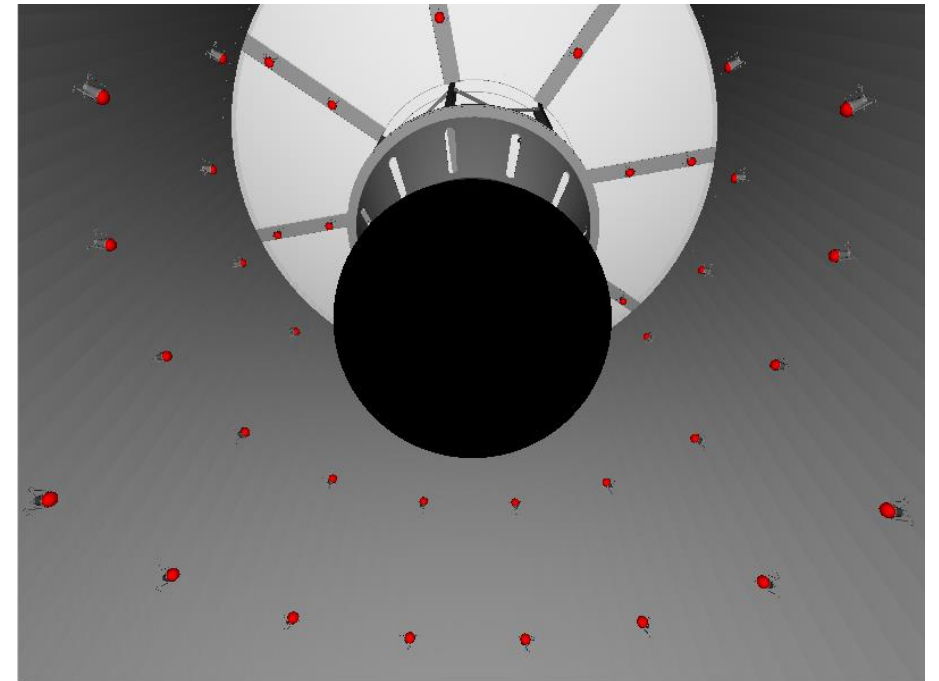
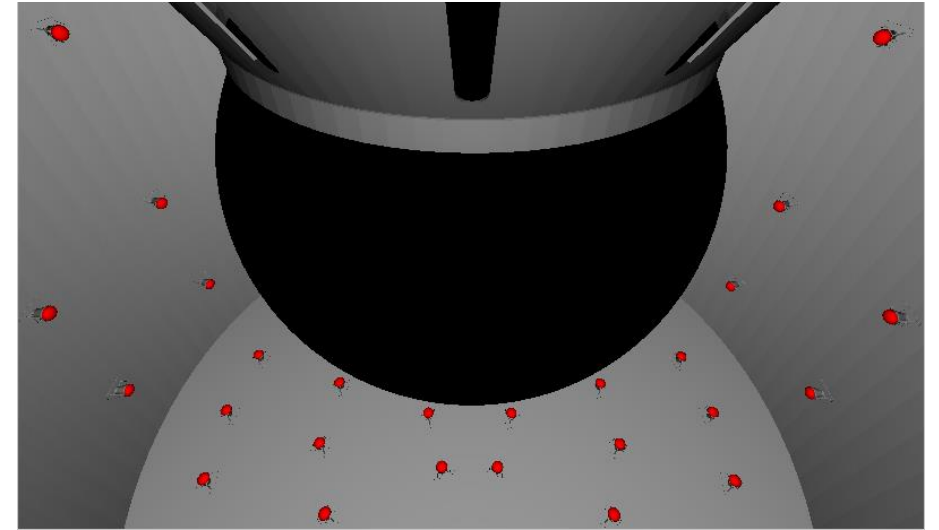

Simulation Parameters

Monitoring and calibration system requirements:

- All PMTs receive at least 10 photons per pulse
- All PMTs receive no more than 10^7 photons per second.

Simulation Parameters

Monitoring and calibration system requirements:

- All PMTs receive at least 10 photons per pulse
- All PMTs receive no more than 10^7 photons per second.

Light Generator:
Photon Bomb

Simulation Parameters

Monitoring and calibration system requirements:

- All PMTs receive at least 10 photons per pulse
- All PMTs receive no more than 10^7 photons per second.

Light Generator:
Photon Bomb

Wavelength:
390 nm

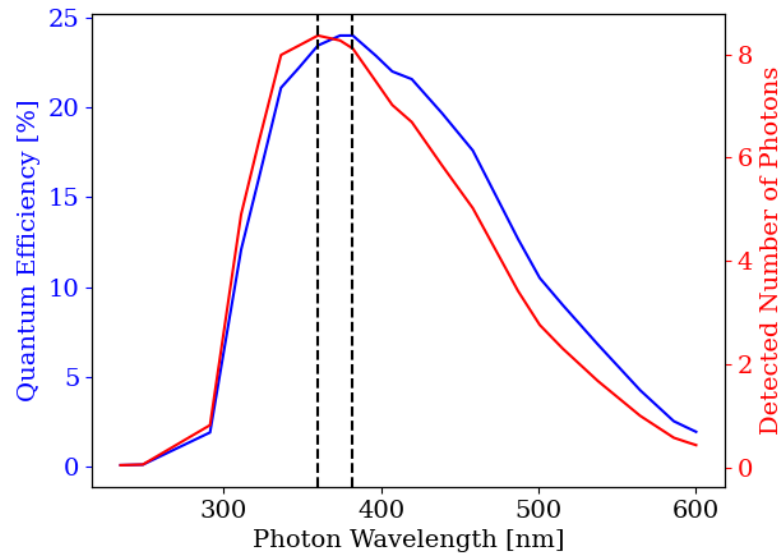

Simulation Parameters

Monitoring and calibration system requirements:

- All PMTs receive at least 10 photons per pulse
- All PMTs receive no more than 10^7 photons per second.

Light Generator:
Photon Bomb

Wavelength:
390 nm

Initial Intensity:
2,000,000

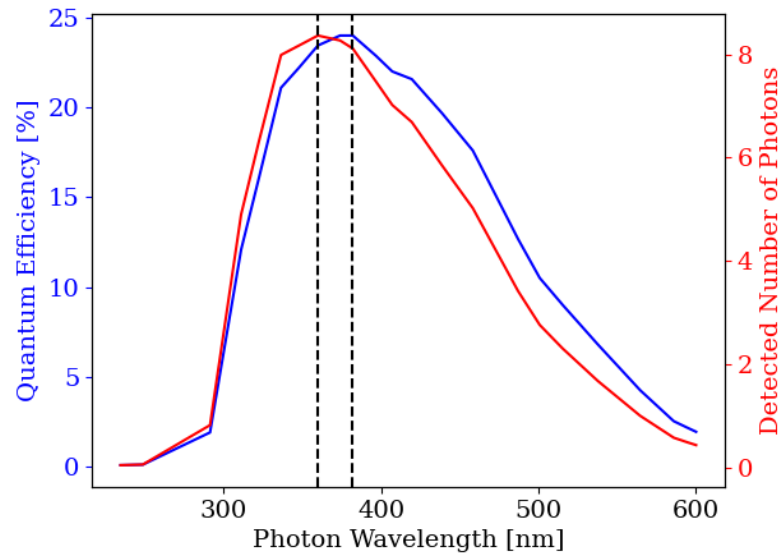

Simulation: Concept Validation

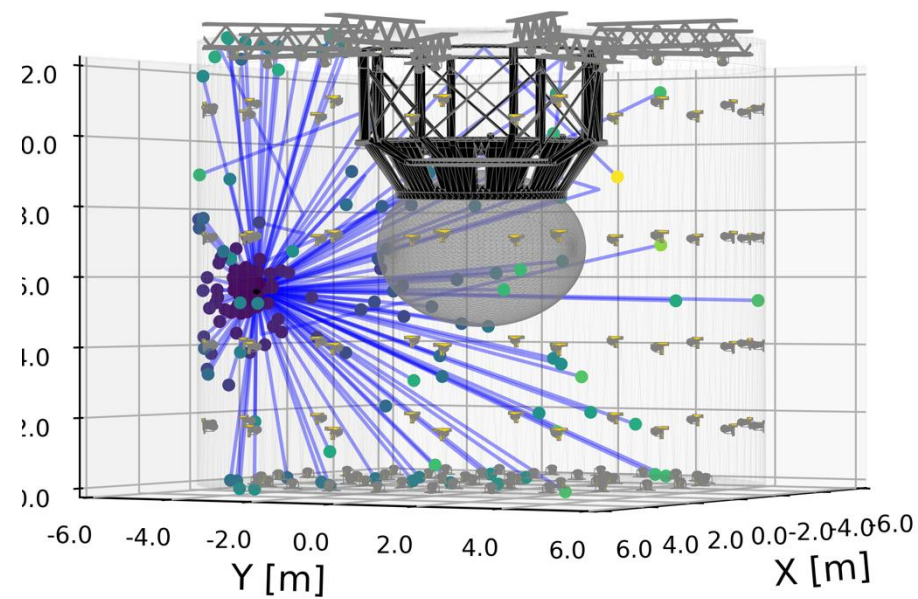
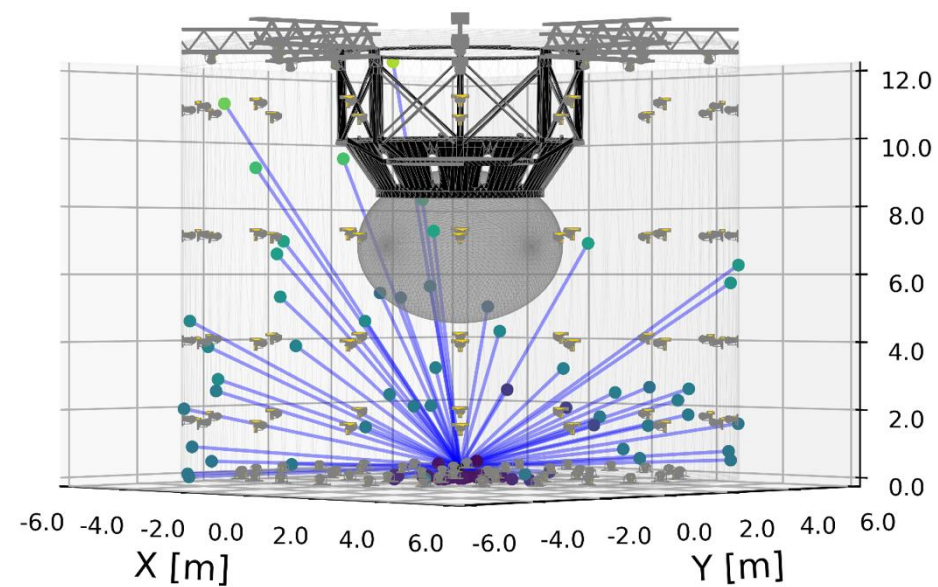
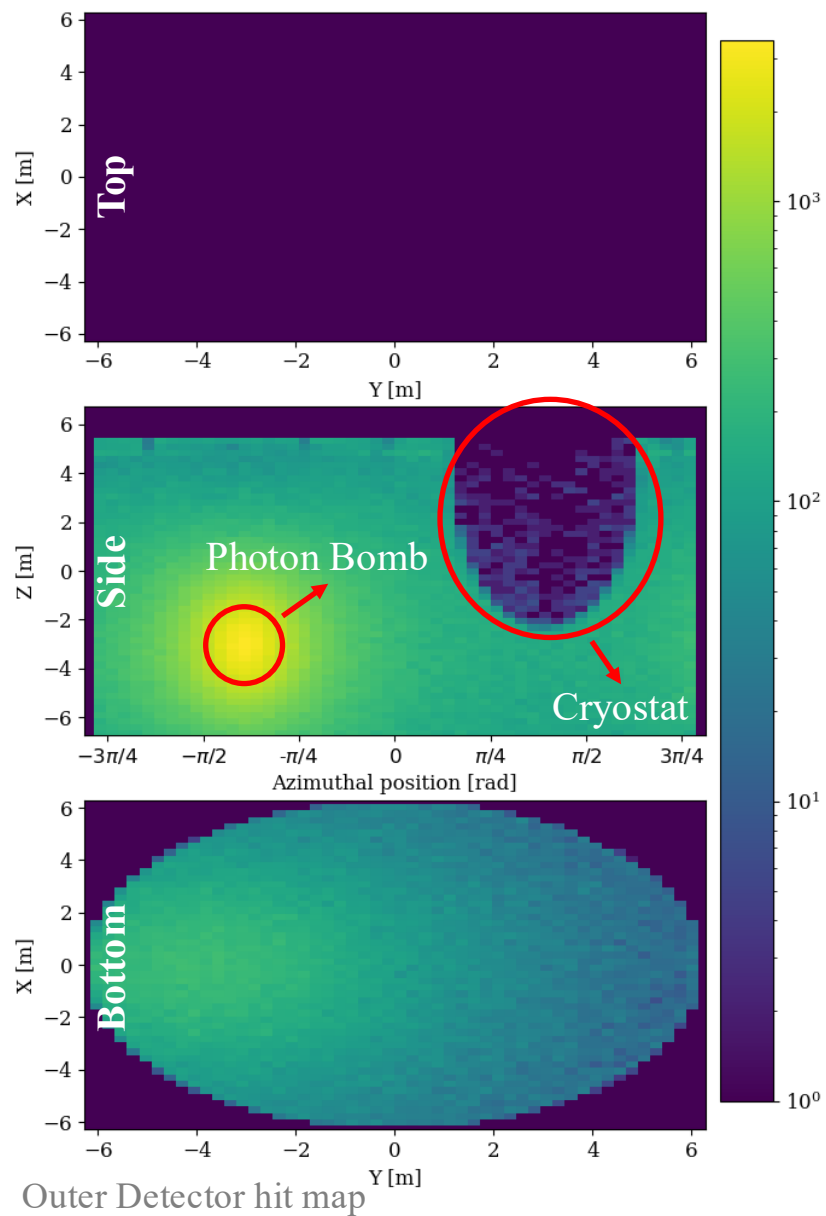

Simulation: Optimization

- A single DORY cannot illuminate all PMTs due to shadowing by the cryostat.
- Using two or three DORY units requires high initial light intensity, causing saturation of nearby PMTs.
- Four DORY units can illuminate all PMTs in a specific configuration.
- We chose **five DORY units** as the optimal setup to ensure full coverage and provide redundancy in case one unit fails.
- As long as the five DORY units are distributed **uniformly** around the tank, the system operates effectively.

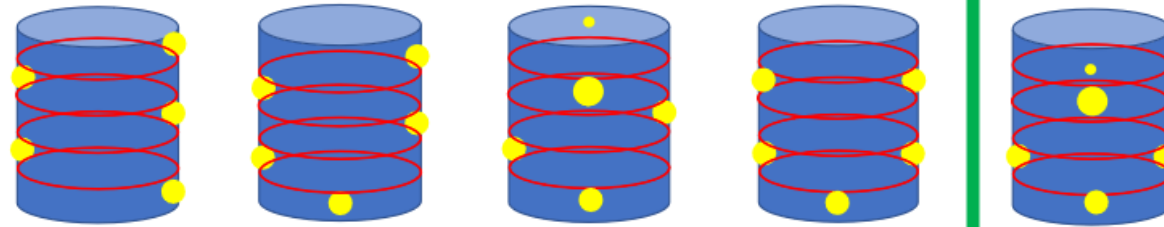

Configuration ID	5.0	5.1	5.2	5.3	5.4
Uncalibrated PMT IDs	#70 (8.91 ± 0.38)	-	-	-	-

Configuration ID	4.1	4.2	4.3	4.4
Uncalibrated PMT IDs	#8 (7.61 ± 0.33) #70 (8.91 ± 0.38) #83 (10.39 ± 0.43)	#8 (7.61 ± 0.33) #70 (8.91 ± 0.38)	#70 (9.76 ± 0.33) #83 (9.33 ± 0.33)	-



Irina Nitu

Simulation: DORY Emission Profile

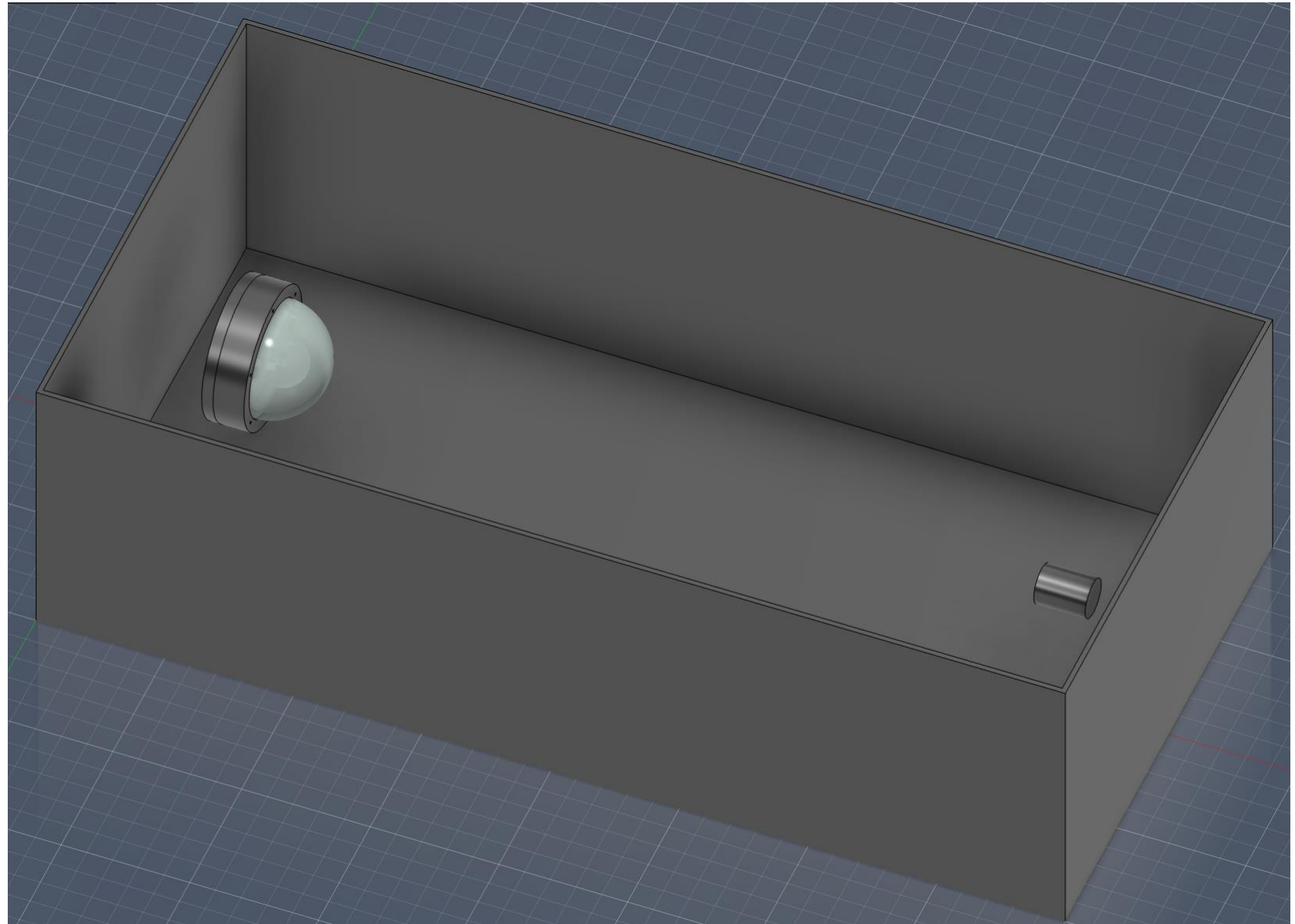

David Paz

Simulation: DORY Emission Profile

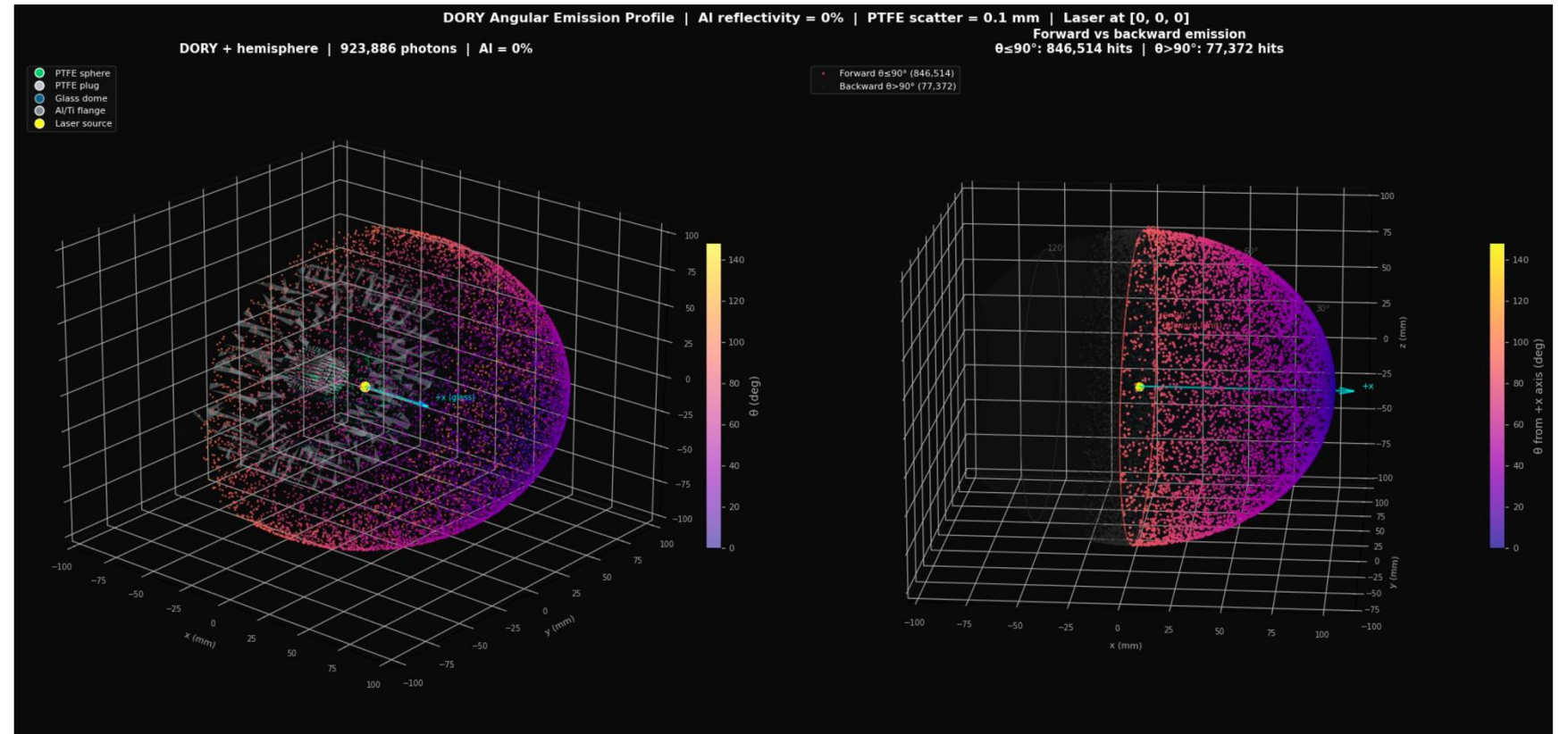
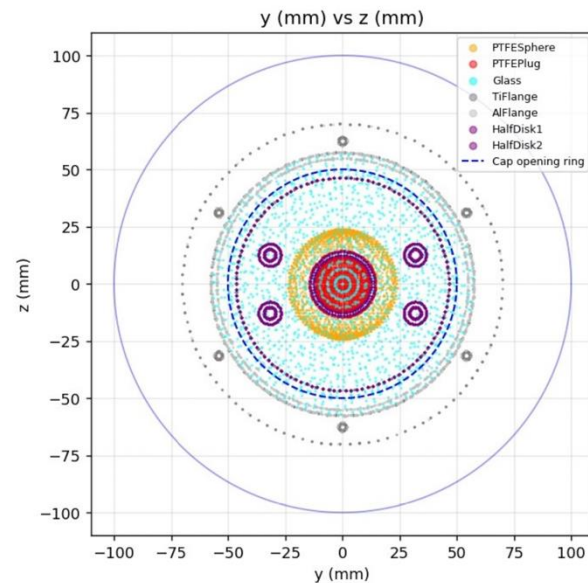
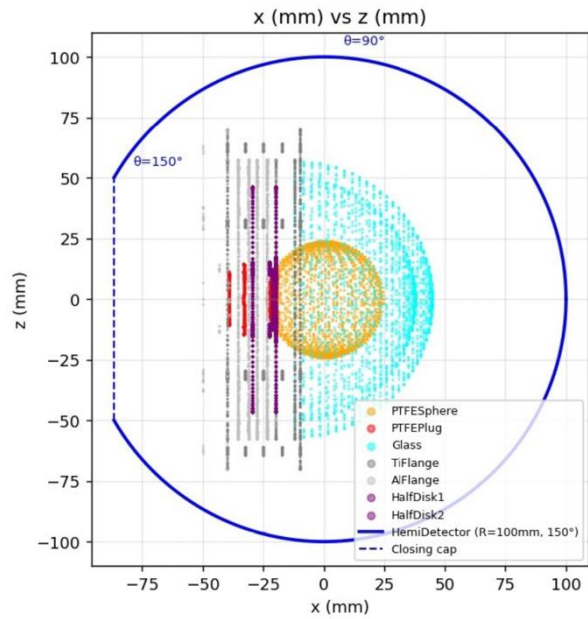

Material	n	λ_s (mm)	λ_a (mm)	Reflectivity
PTFE	1.35	0.1	10,000	Diffuse
Borosilicate glass	1.52	10,000	10,000	None
Aluminum	1.0	100,000	0.0001	0% (default)
Titanium	1.0	100,000	0.0001	0% (fully absorbing)
Air	1.0003	100,000	100,000	None

Simulation: DORY Emission Profile

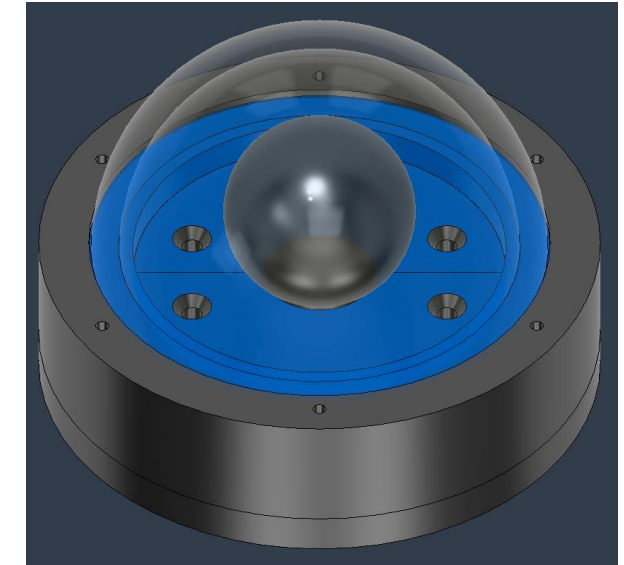
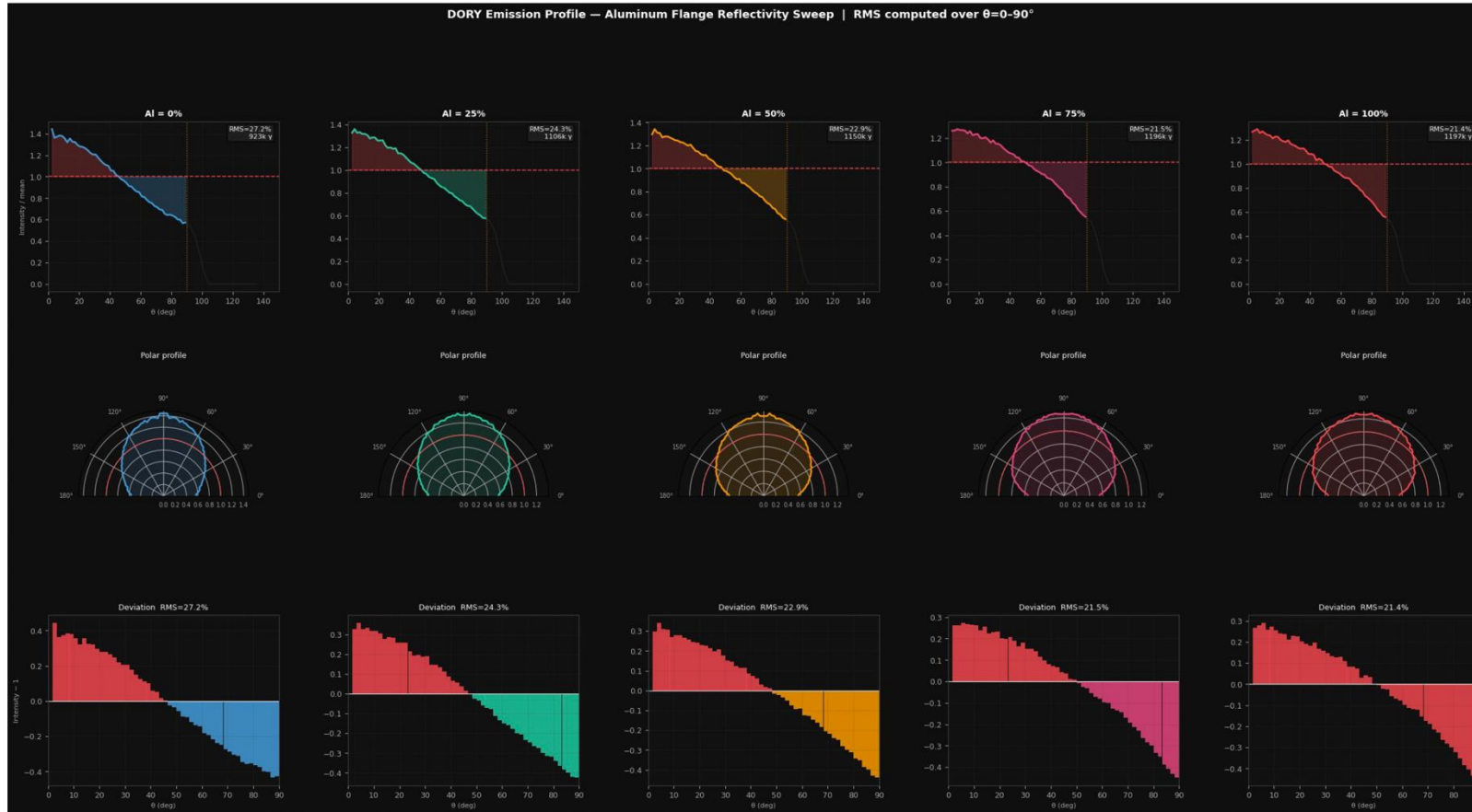

R_{AI} (%)	Photons on hemisphere	σ_{RMS} (%)
0	923,886	27.2
25	1,106,846	24.3
50	1,150,897	22.9
75	1,196,649	21.6
100	1,197,998	21.4

Simulation: DORY Emission Profile

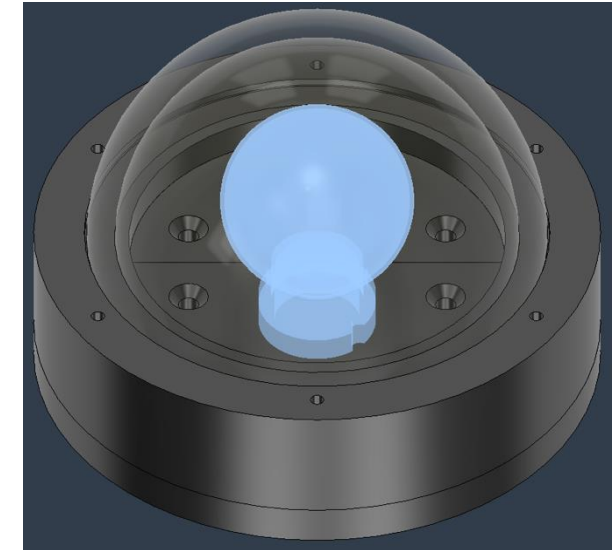

λ_s (mm)	Photons on hemisphere	σ_{RMS} (%)
0.05	743,621	22.4
0.1	1,067,819	26.1
0.5	1,450,383	48.0
1.0	1,549,017	65.1
2.0	1,628,901	79.2

Simulation: DORY Emission Profile

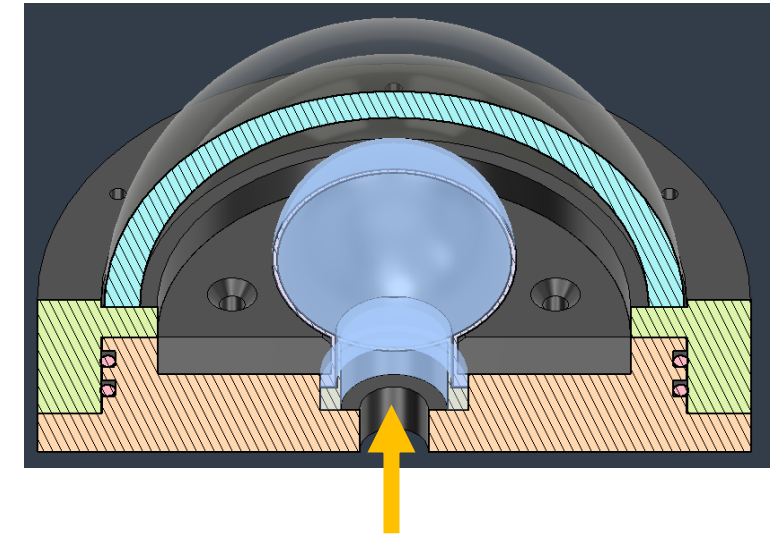

x (mm)	Photons on hemisphere	σ_{RMS} (%)
-35.0	57,895	4.6
-26.6	100,767	4.3
-19.0	1,025,344	7.1
-10.0	1,056,926	14.1
0.0	1,067,232	26.2

Simulations: Optimizing DORY Design



Configuration	R_{Al} (%)	λ_s (mm)	σ_{RMS} (%)
Current DORY ($x = 0$)	0	0.1	21.4
Current DORY, $x = -26.6$	0	0.1	9.0
Al run, plug position	95	0.1	9.6
	80	0.1	8.3
Short scatter + Al run	0	0.05	8.6
	80	0.05	10.6
Default scatter + Al run	0	0.1	4.7
	10	0.1	4.6
Combined optimum	20	0.1	3.9
	40	0.1	5.6

Simulations: DORY Test Setup

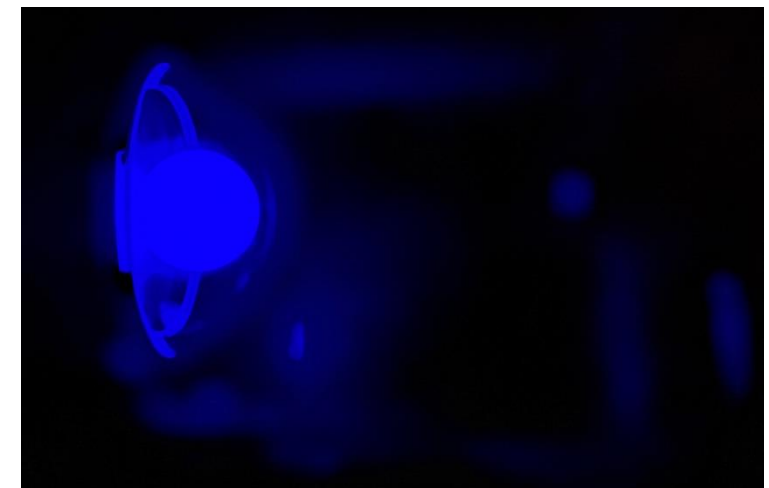
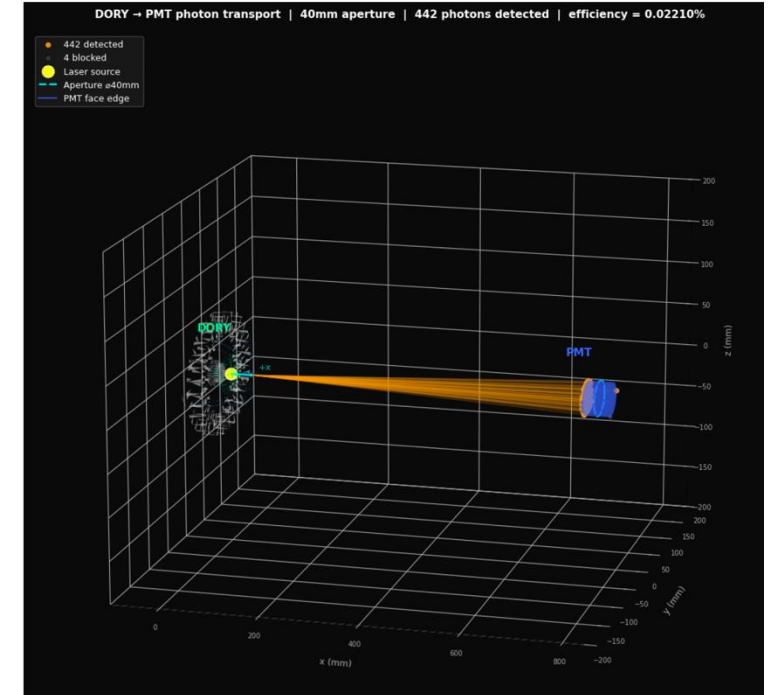

Aperture diam. (mm)	r_{ap} (mm)	N_{det}	η (%)
40 (full)	20.0	442	0.0221 ± 0.0011
30	14.1	232	0.0116 ± 0.0008
20	9.1	105	0.0053 ± 0.0005
10	4.1	19	0.00095 ± 0.00022
5	1.6	0	< 0.0001 (95% CL)

DORY Test Setup

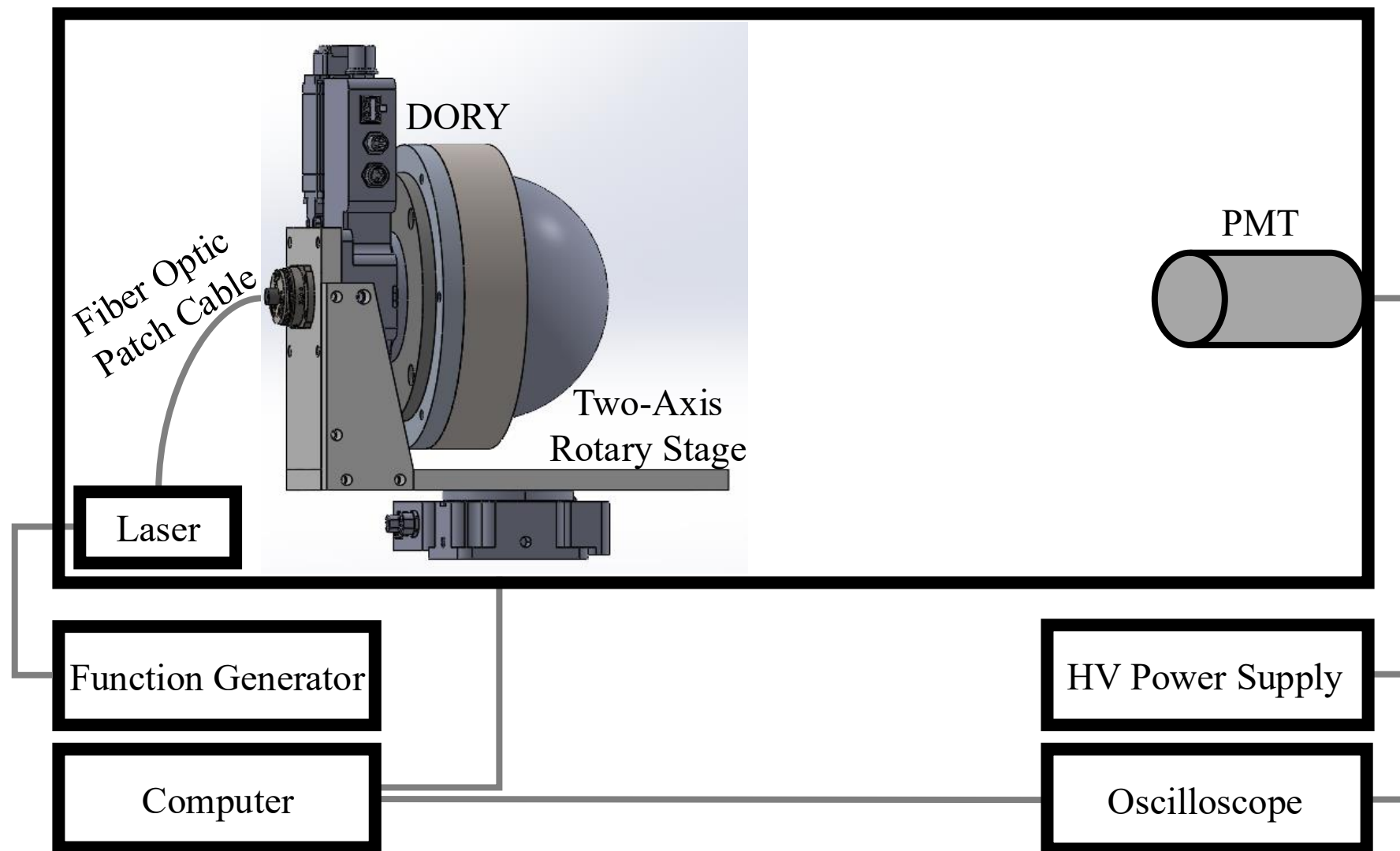

DORY Test Setup

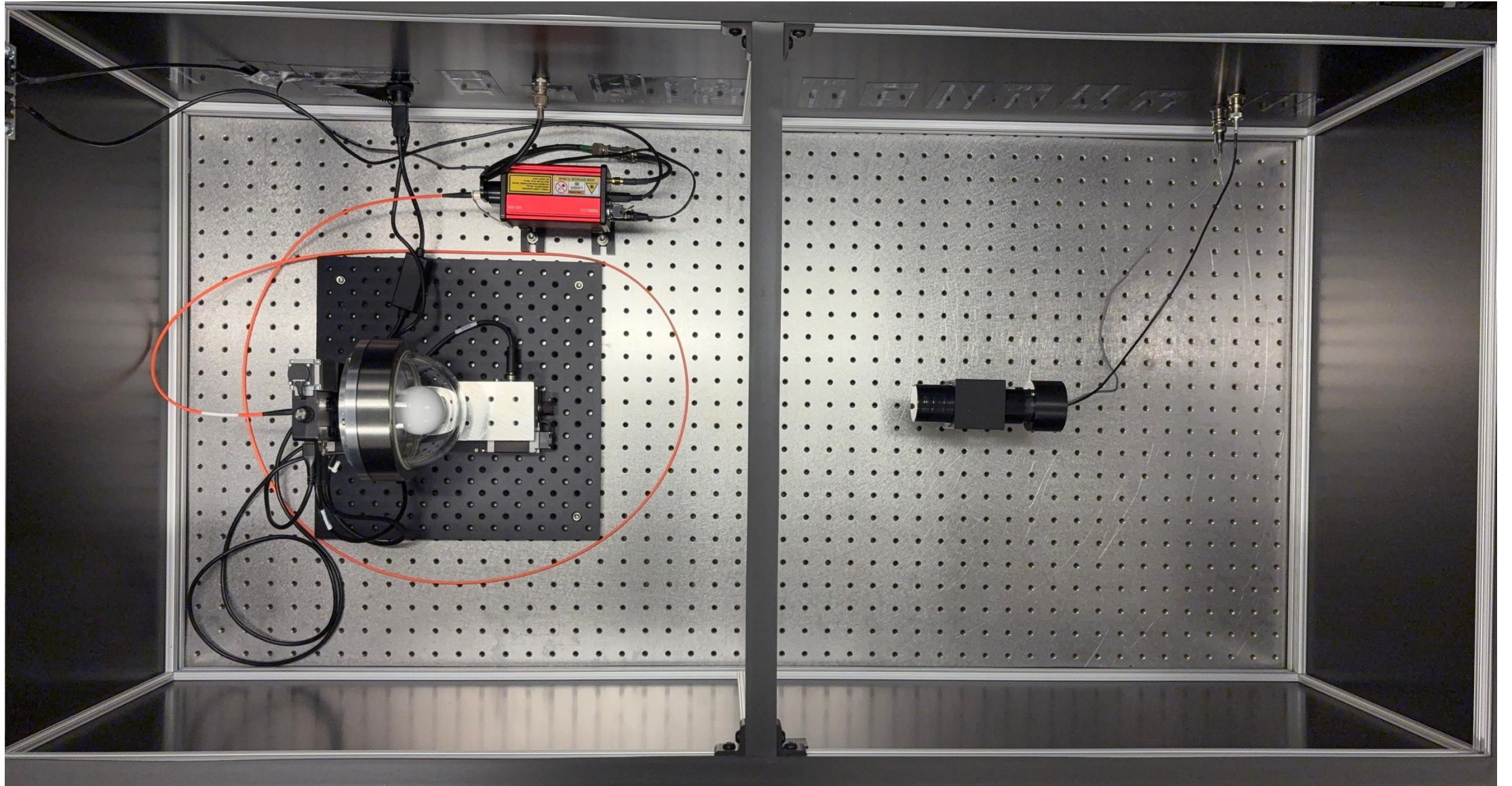

DORY Test Setup DAQ

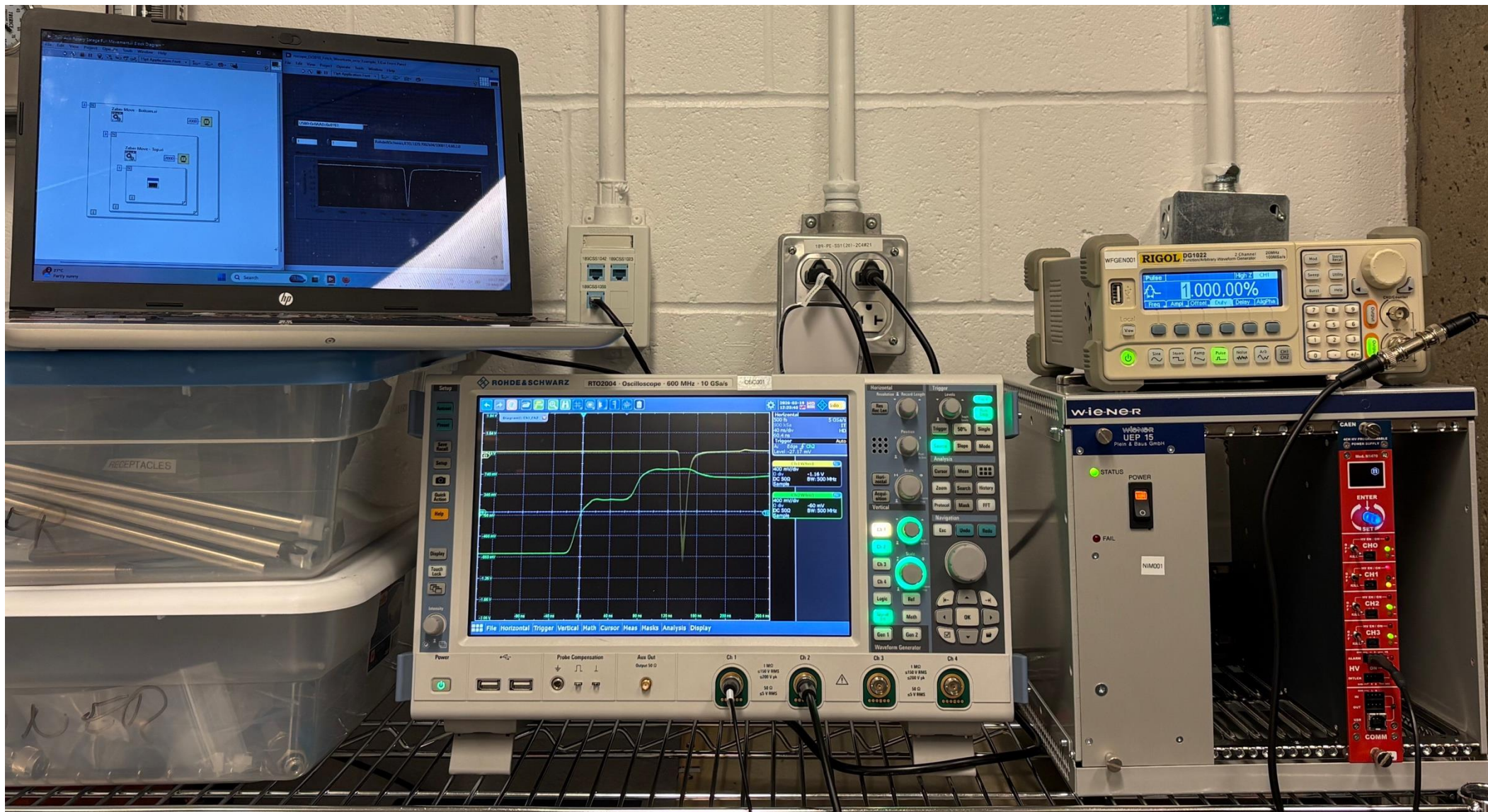

DORY Test Setup: Motorized Two Axis Rotary Stage

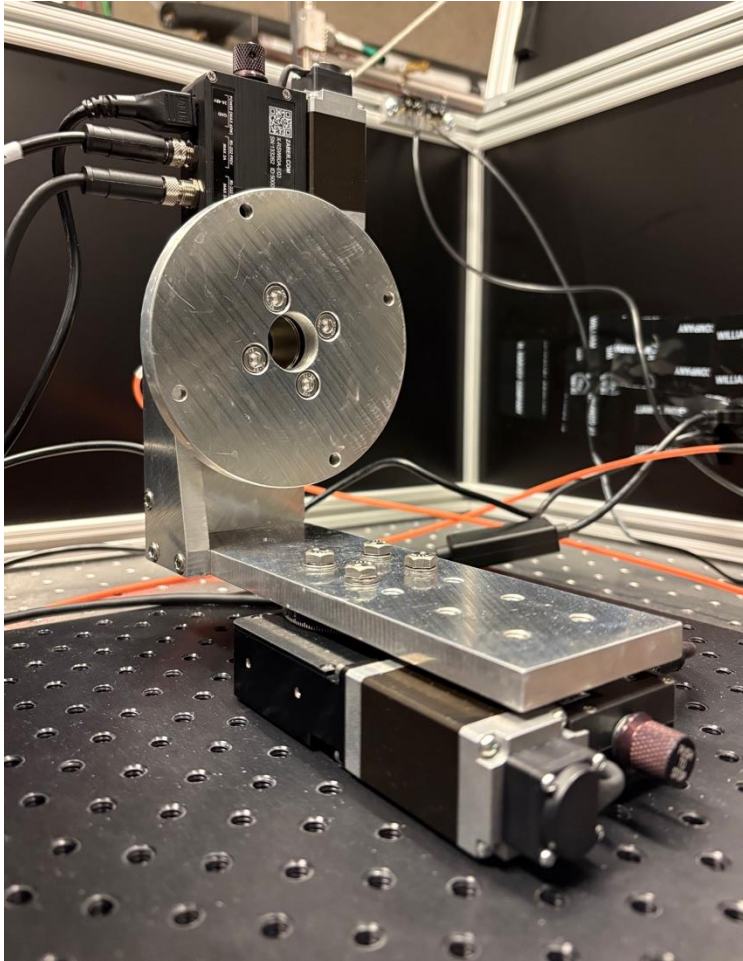

Two Zaber X-RSW60A-E03 motors, an angle bracket, and an adapter plate used to mount DORY.

DORY Test Setup: Motorized Two Axis Rotary Stage

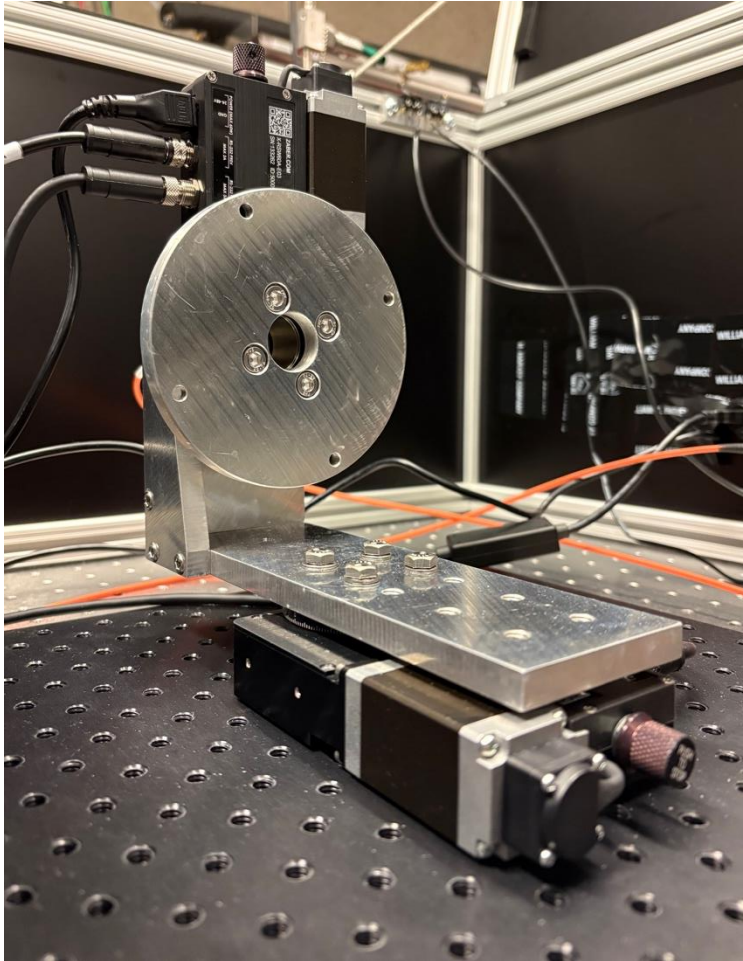

Two Zaber X-RSW60A-E03 motors, an angle bracket, and an adapter plate used to mount DORY.

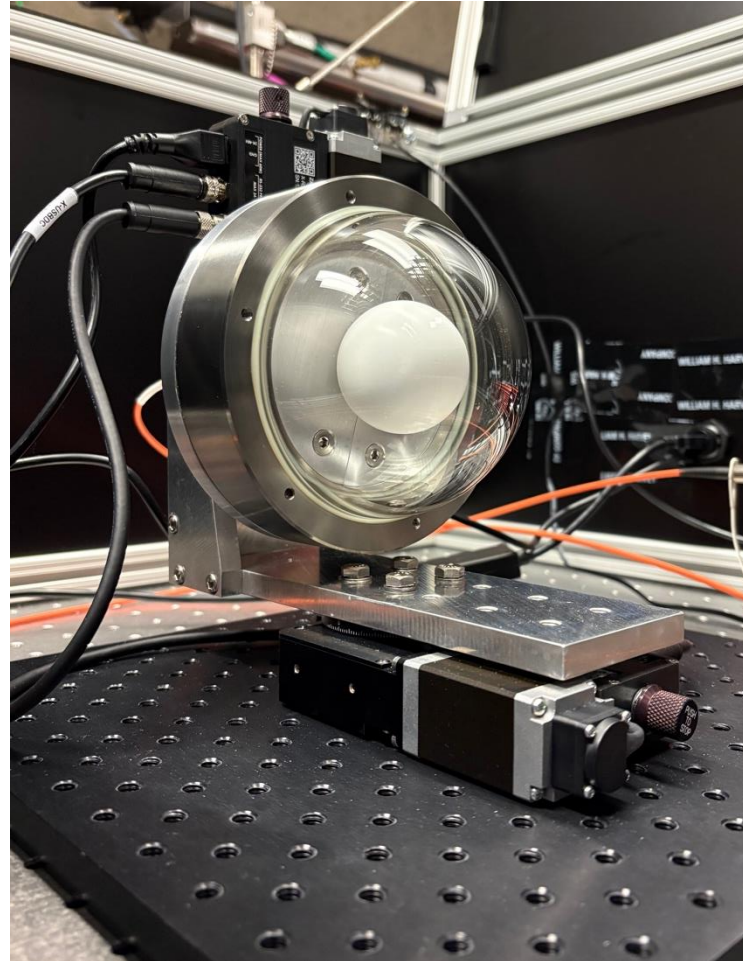

Rotary stage with DORY mounted.

DORY Test Setup: Motorized Two Axis Rotary Stage

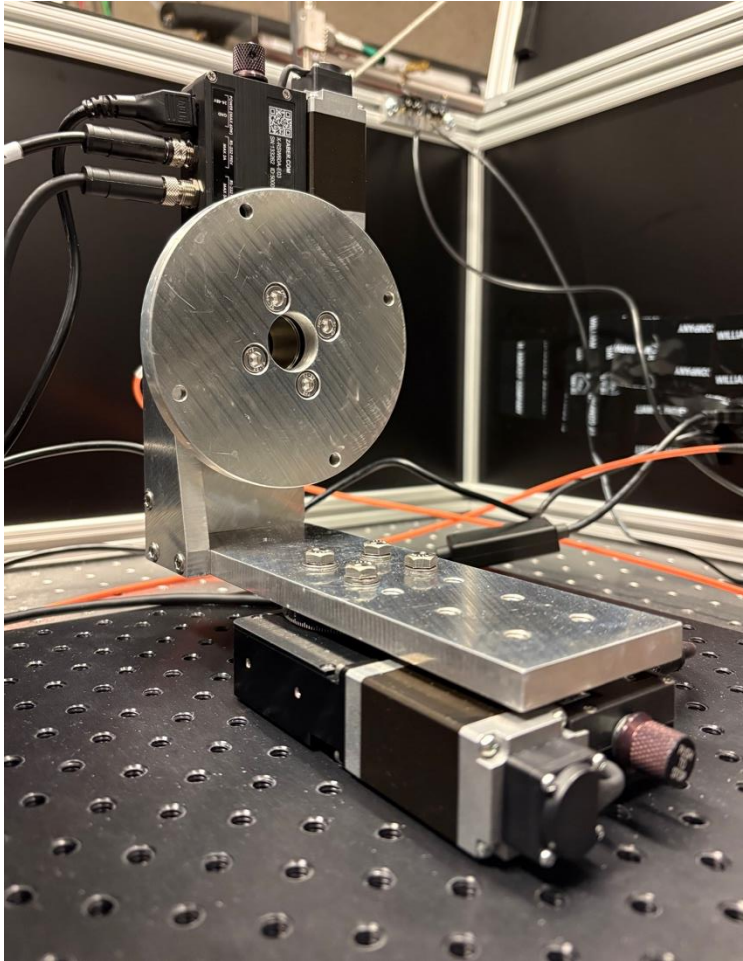

Two Zaber X-RSW60A-E03 motors, an angle bracket, and an adapter plate used to mount DORY.

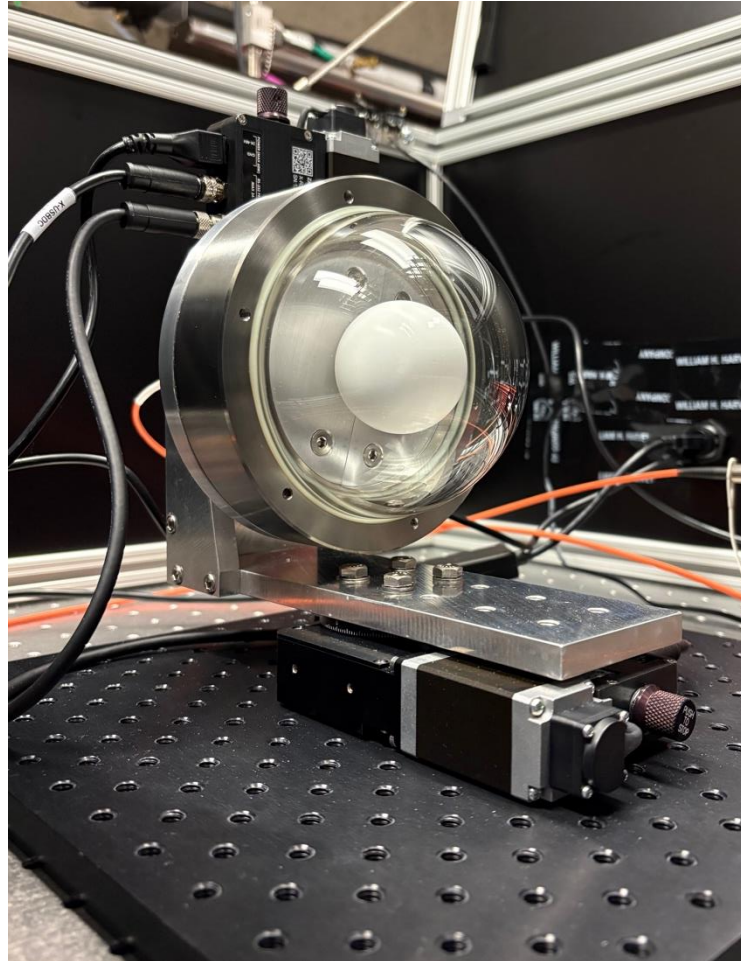

Rotary stage with DORY mounted.

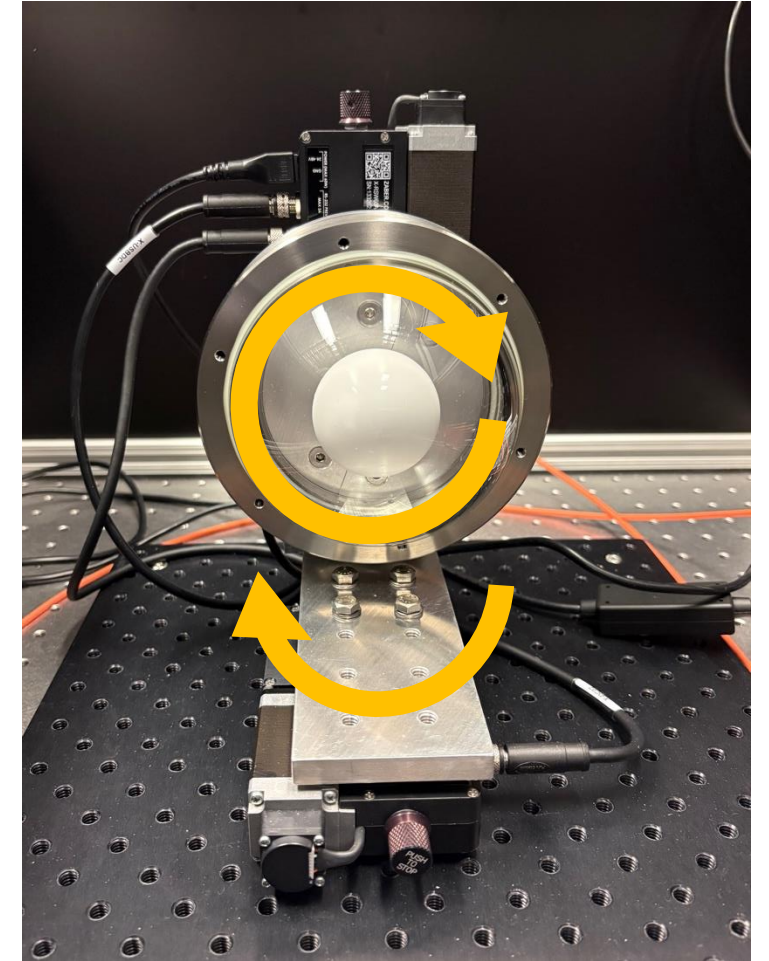

The stage provides 4π rotational coverage, both the polar and azimuthal angles.

DORY Test Setup: Laser

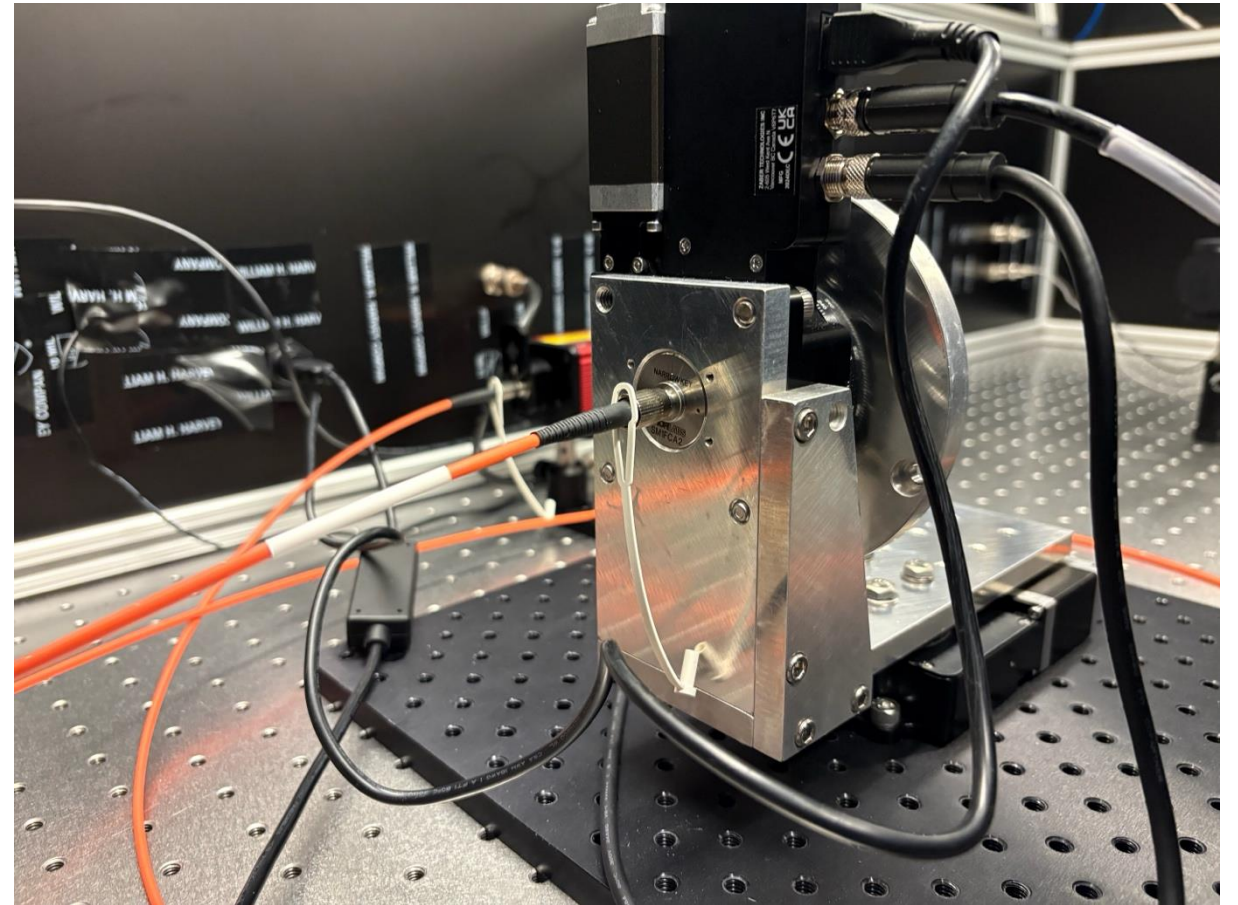
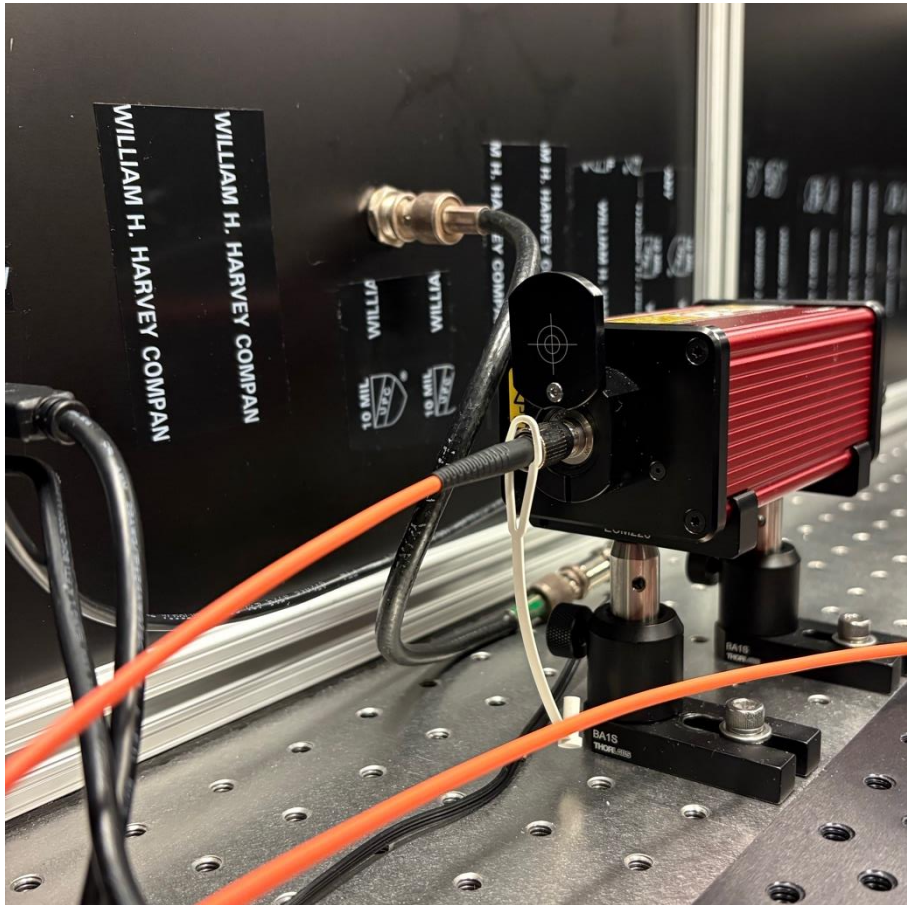

- Laser: Thorlabs NPL45B, 450 nm
- Direct laser-to-fiber coupling via a Thorlabs SM05FCA2 port
- Fiber: Thorlabs M160L02, $\text{\O}600 \mu\text{m}$, 0.22 NA, fiber patch cable
- Fiber is connected to the DORY stage through a SM1FCA2 fiber adapter plate

DORY Test Setup: PMT

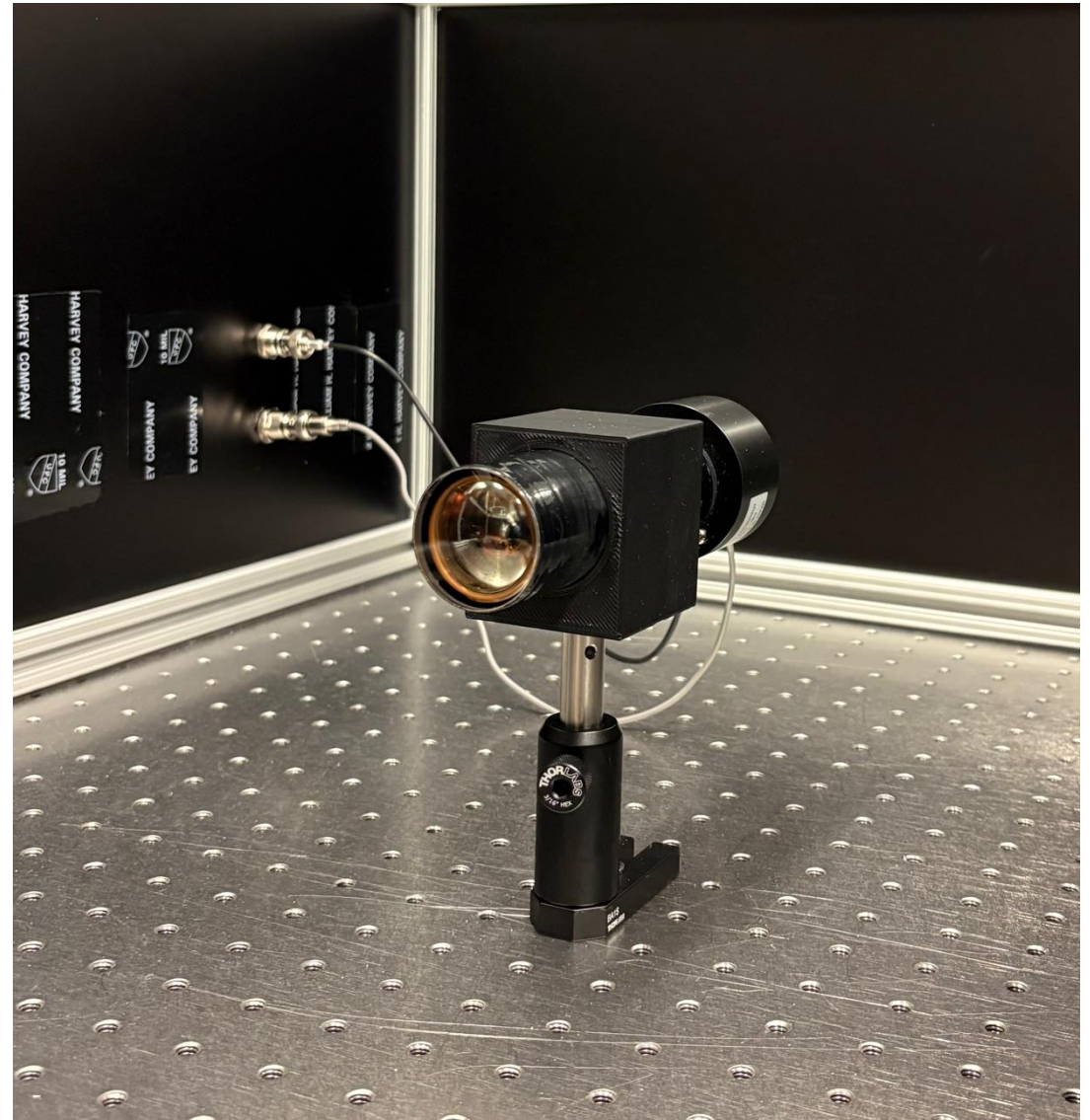
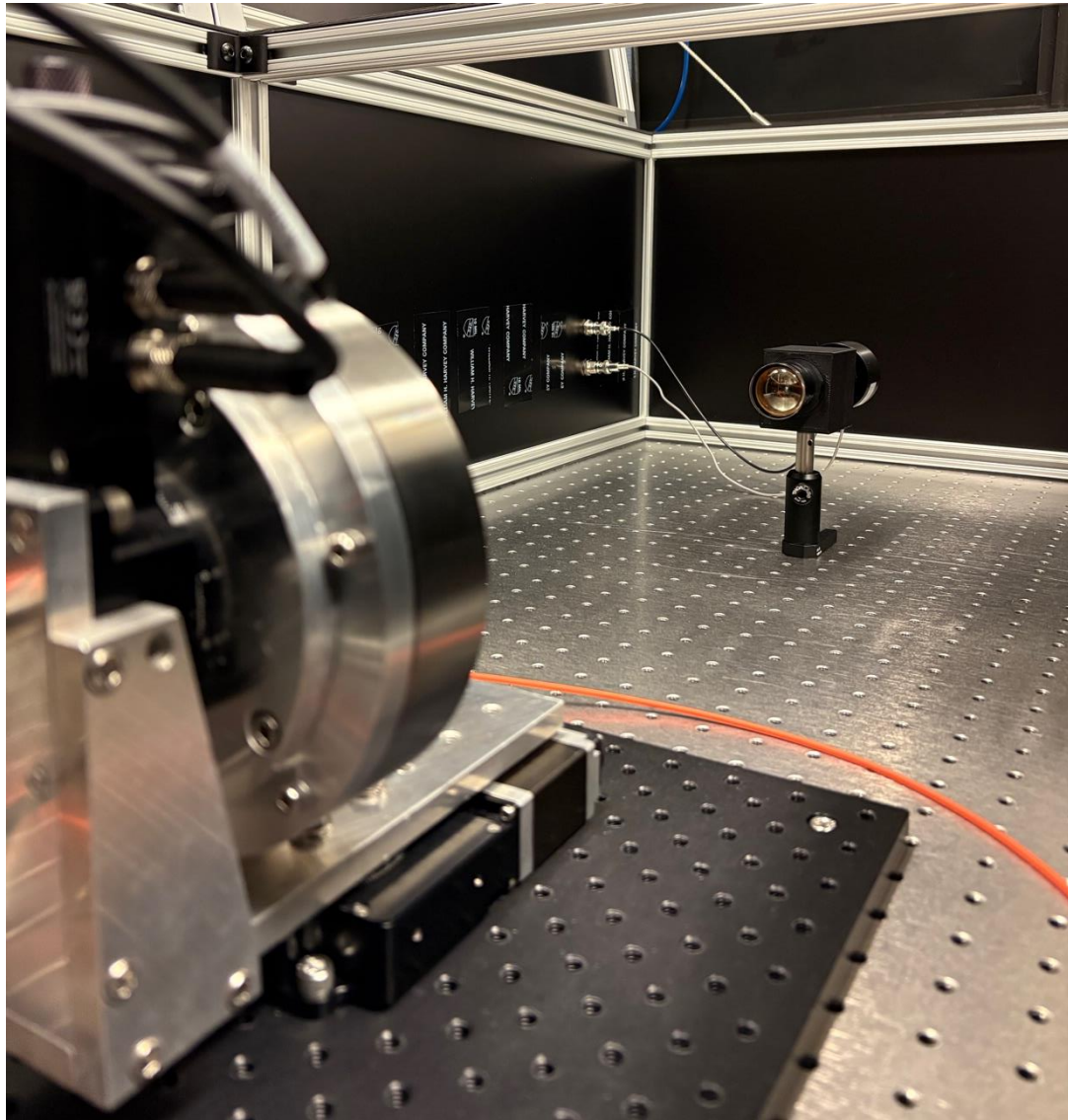

DORY Under Laser Illumination

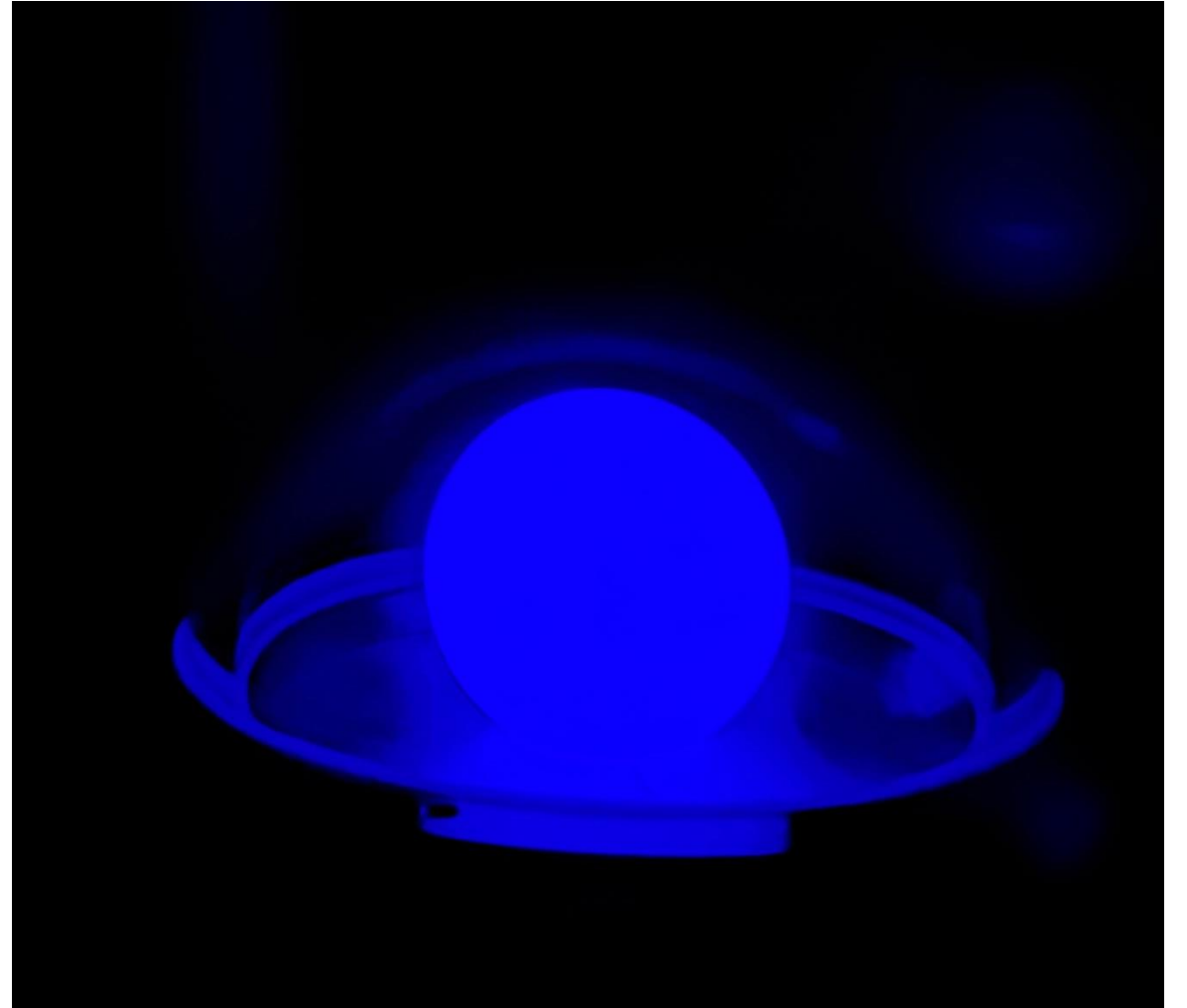

Preliminary Results of Emission Profile Studies

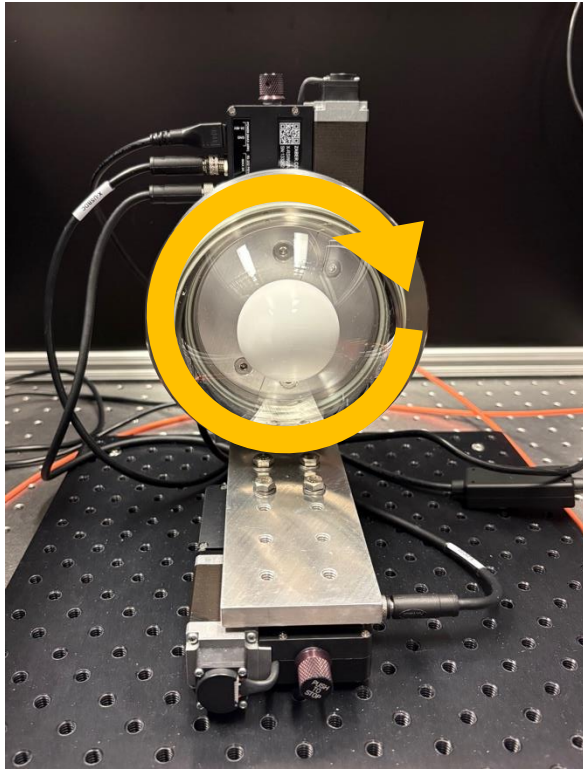

Largest |amplitude|:
2.31 V at 220°

Smallest |Amplitude|:
1.53 V at 74°

Mean |amplitude|:
1.89 V

Median |amplitude|:
1.88 V

Std deviation:
0.15 V

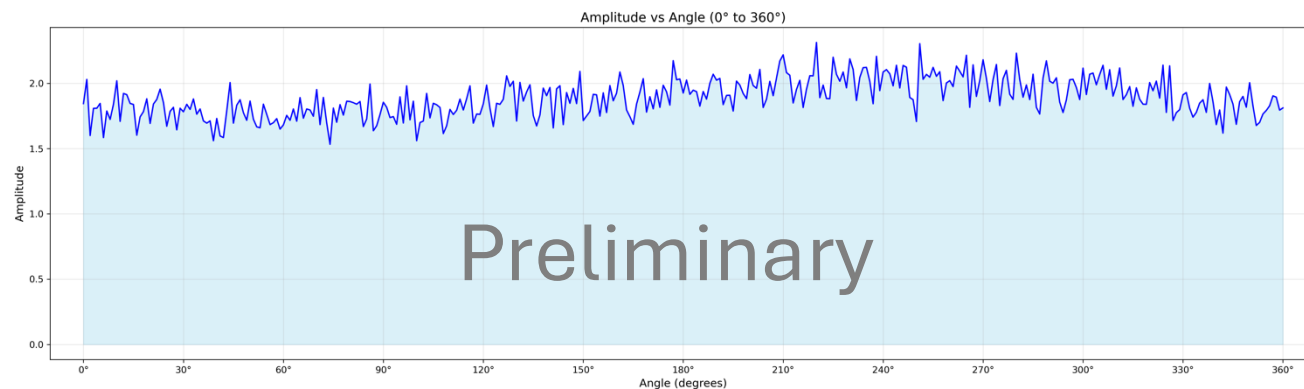
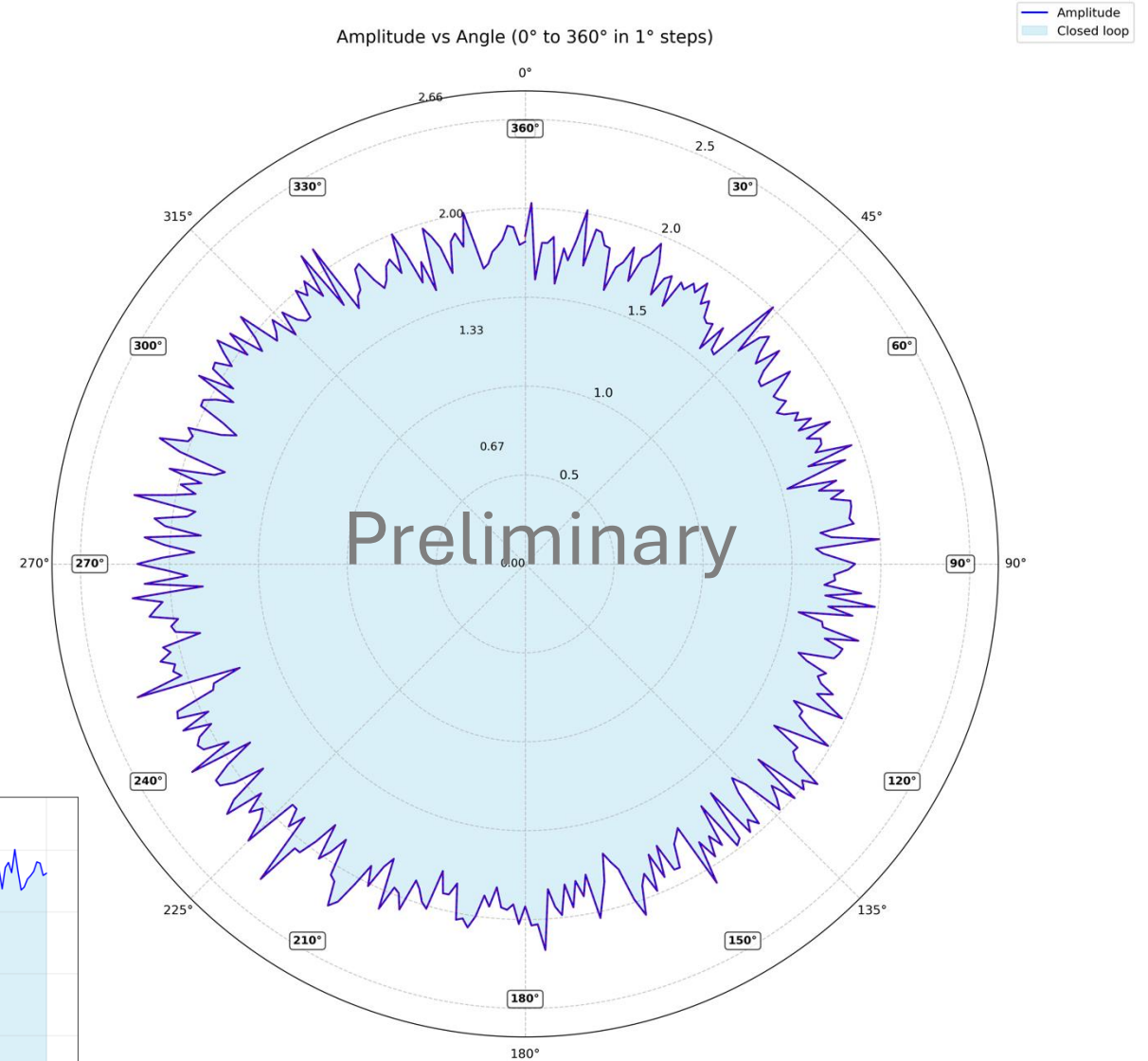

Preliminary Results of Emission Profile Studies

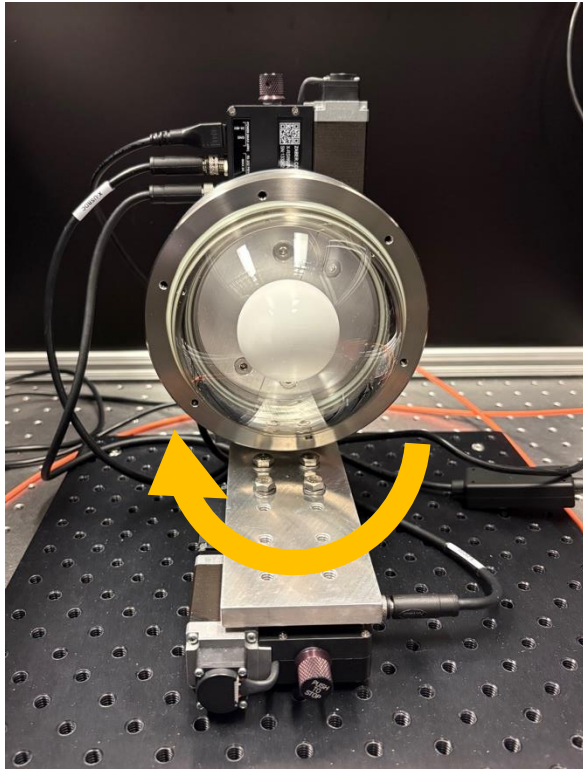

Largest |amplitude|:
2.31 V at 41°

Smallest |Amplitude|:
1.10 V at 179°

Mean |amplitude|:
1.89 V

Median |amplitude|:
1.88 V

Std deviation:
0.23 V

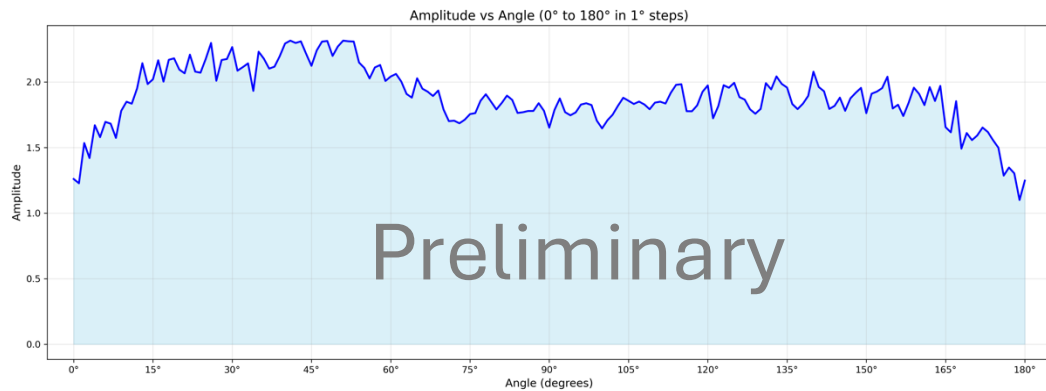
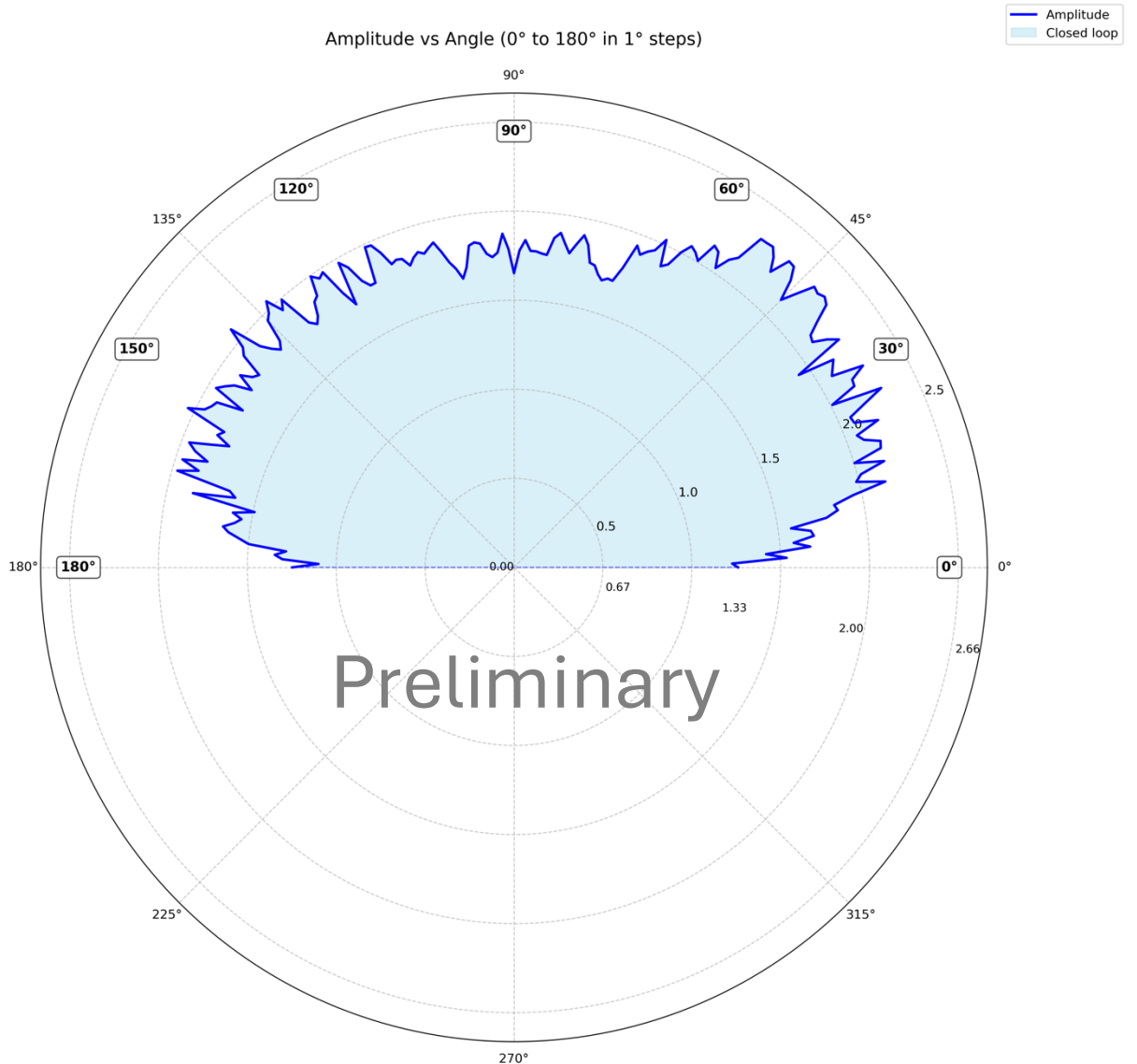

Installation of DORY in the Outer Detector Water Tank

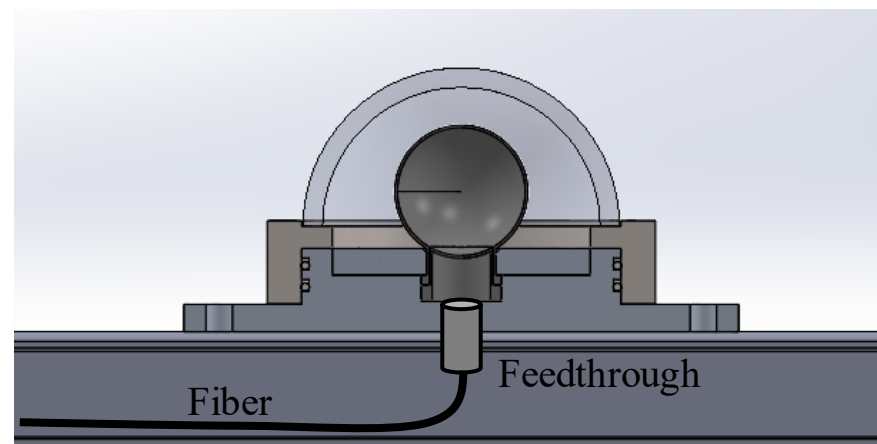
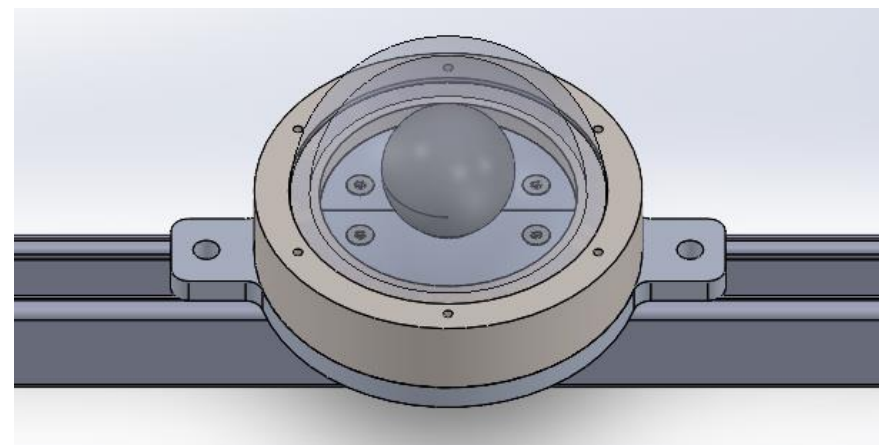
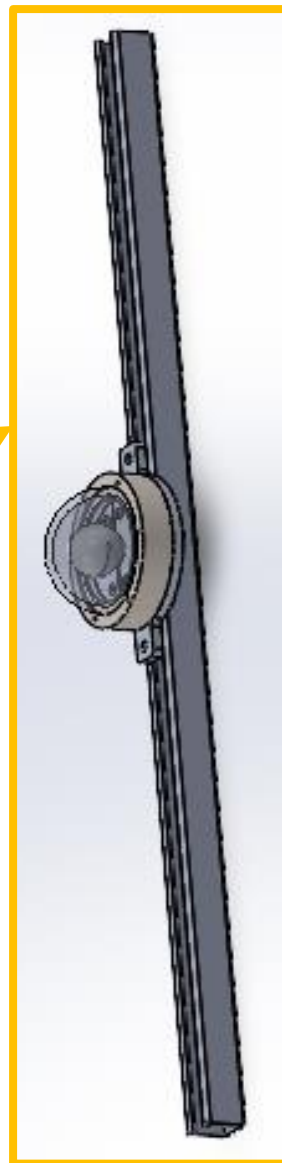
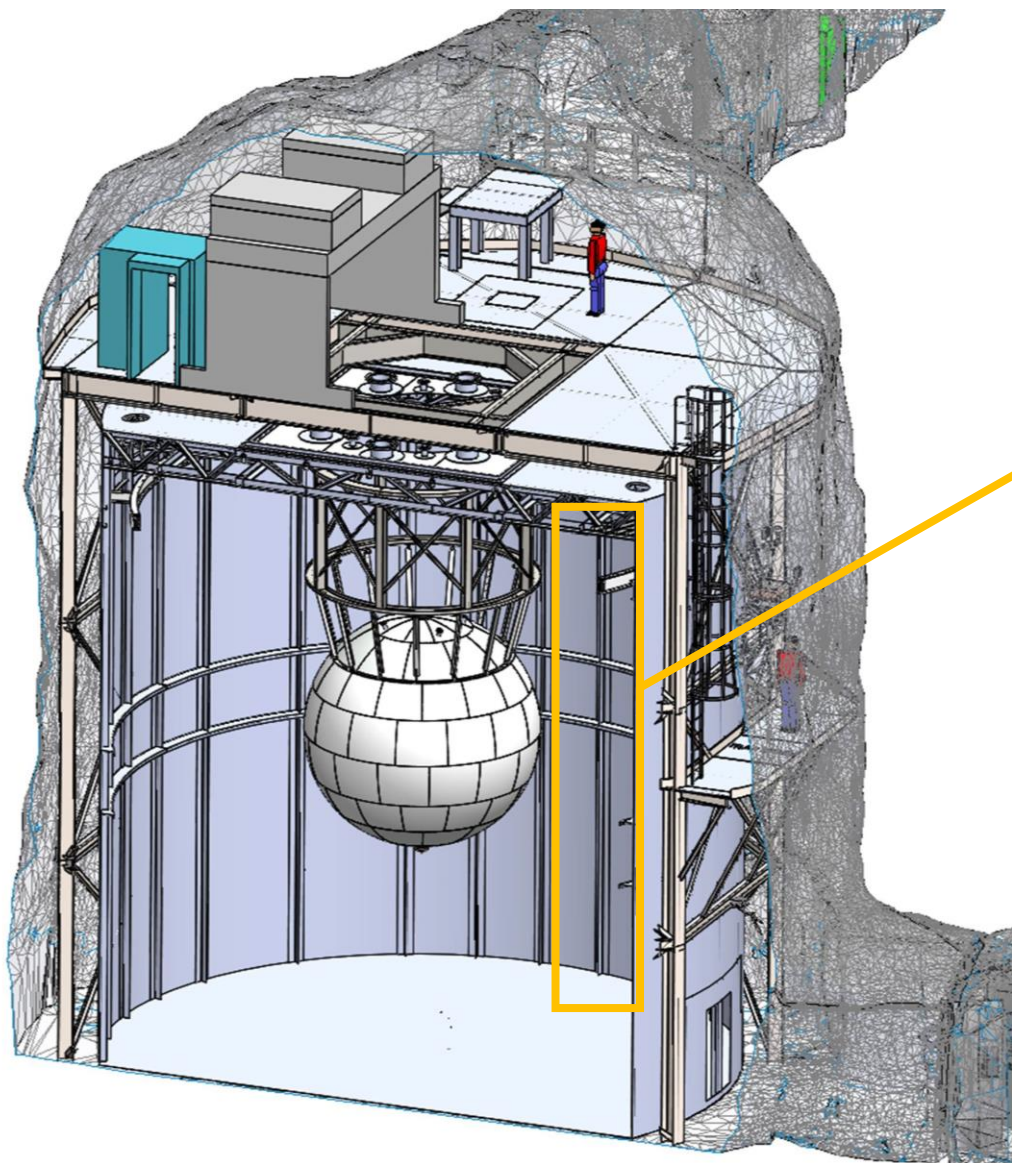

Not drawn to scale.

DORY Upgrades

Coating the internal surfaces of DORY with a low-reflectivity material to improve the isotropy of the emission profile.

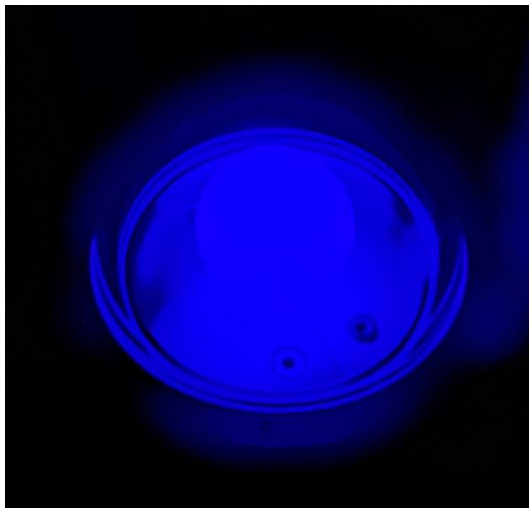
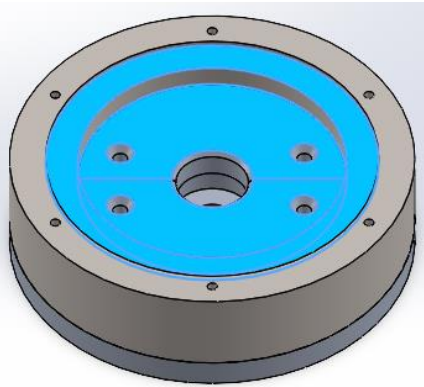

DORY Upgrades

Coating the internal surfaces of DORY with a low-reflectivity material to improve the isotropy of the emission profile.

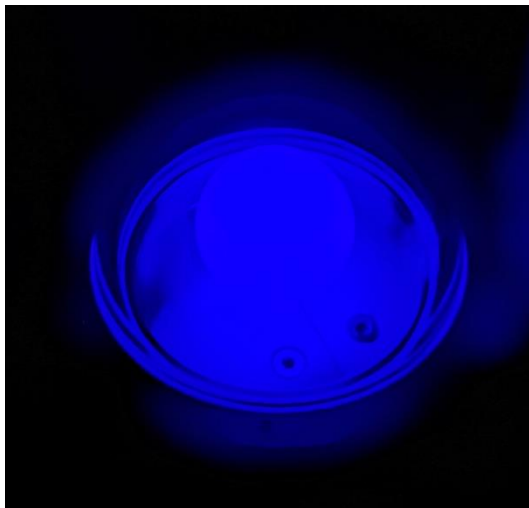
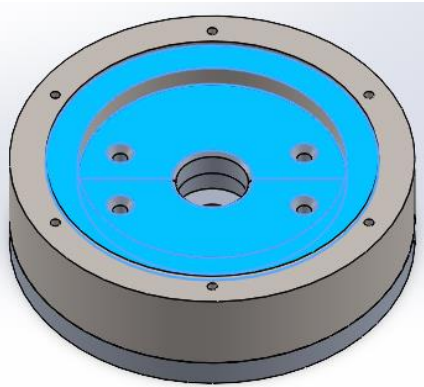

Addition of a self-monitoring photosensor and modification of the back opening to accommodate required feedthroughs

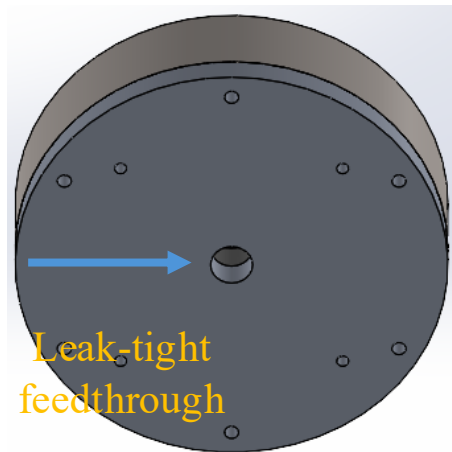
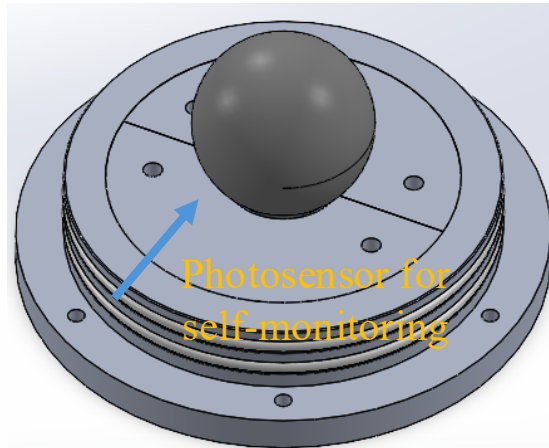

DORY Upgrades

Coating the internal surfaces of DORY with a low-reflectivity material to improve the isotropy of the emission profile.

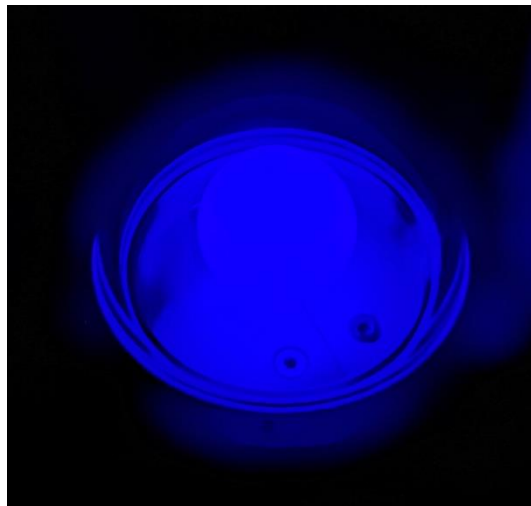
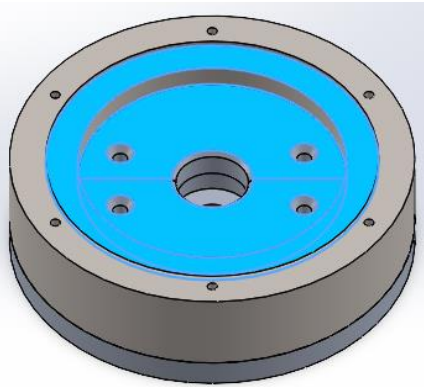

Addition of a self-monitoring photosensor and modification of the back opening to accommodate required feedthroughs

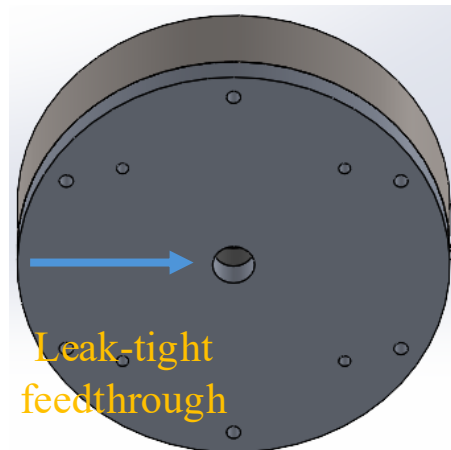
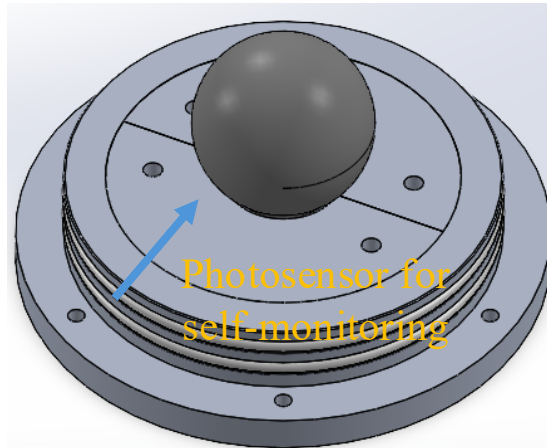

Modifying the flange design to improve installation and integration.

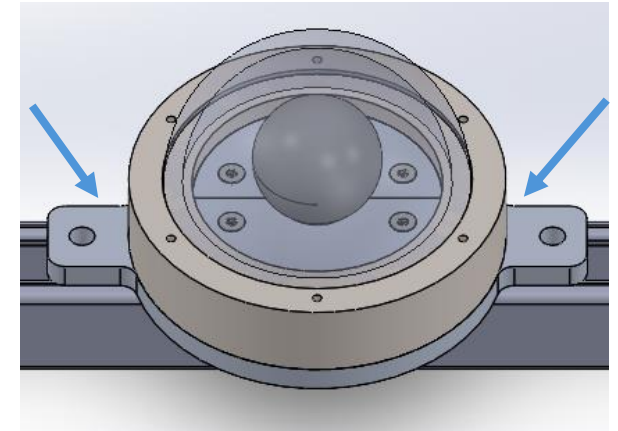

DORY Upgrades

Coating the internal surfaces of DORY with a low-reflectivity material to improve the isotropy of the emission profile.

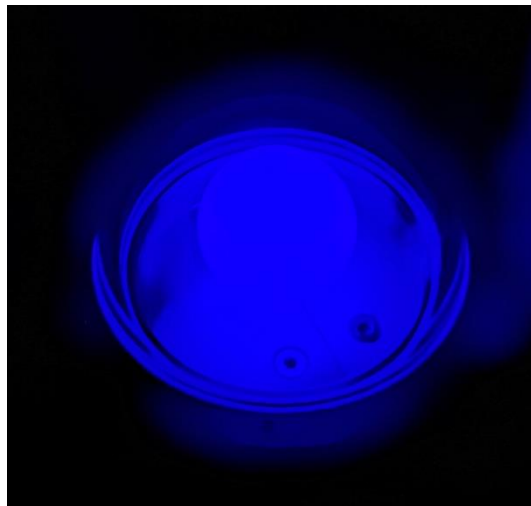
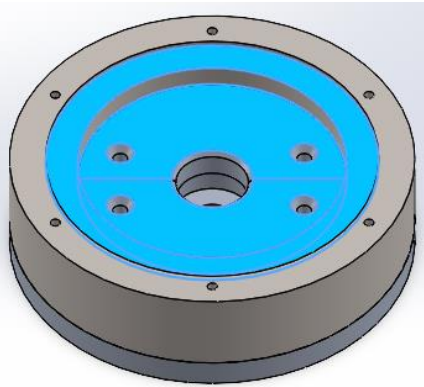

Addition of a self-monitoring photosensor and modification of the back opening to accommodate required feedthroughs

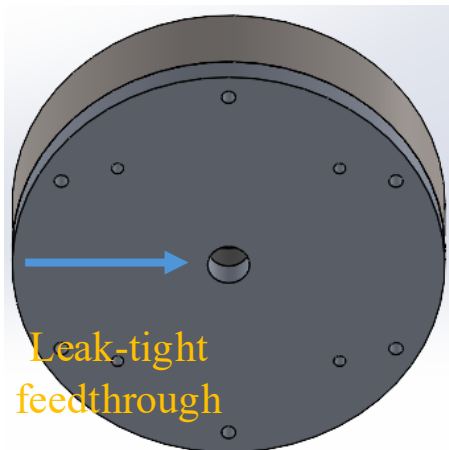
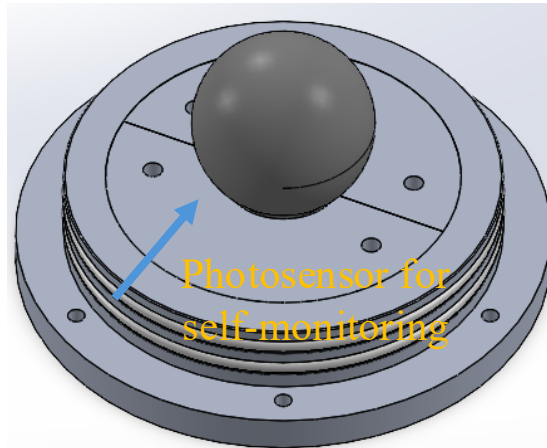

Modifying the flange design to improve installation and integration.

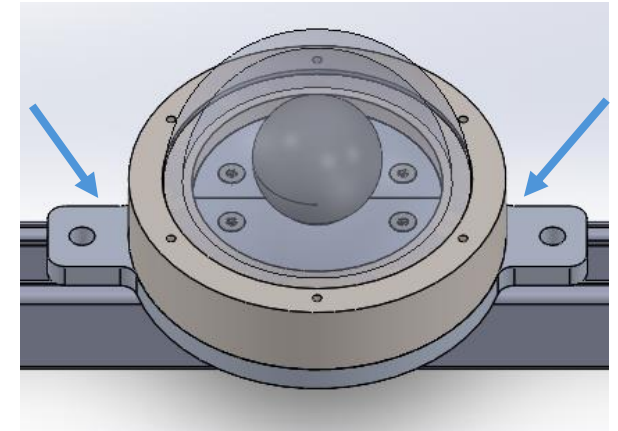

Improving disassembly.

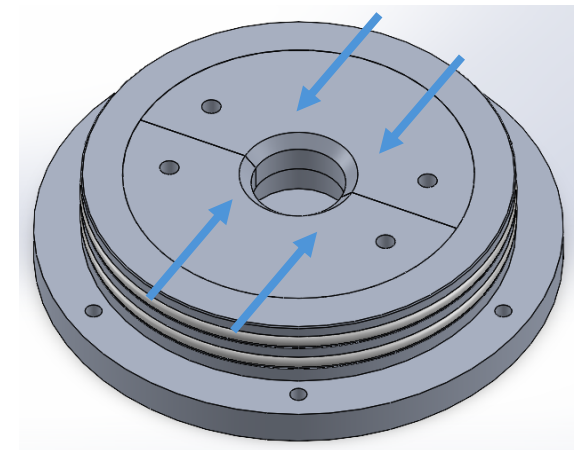

In a Nutshell

DORY Development

First prototype built

Upgrades planned

Test Setup

Characterizing full angular emission

Installation

DORY units mounted on floor or walls using unistruts

Simulation Work

Concept validated with Chroma

Optimized system parameters

Emission profile and design optimizations



The Future of DORY

But the story of
DORY doesn't
end here...

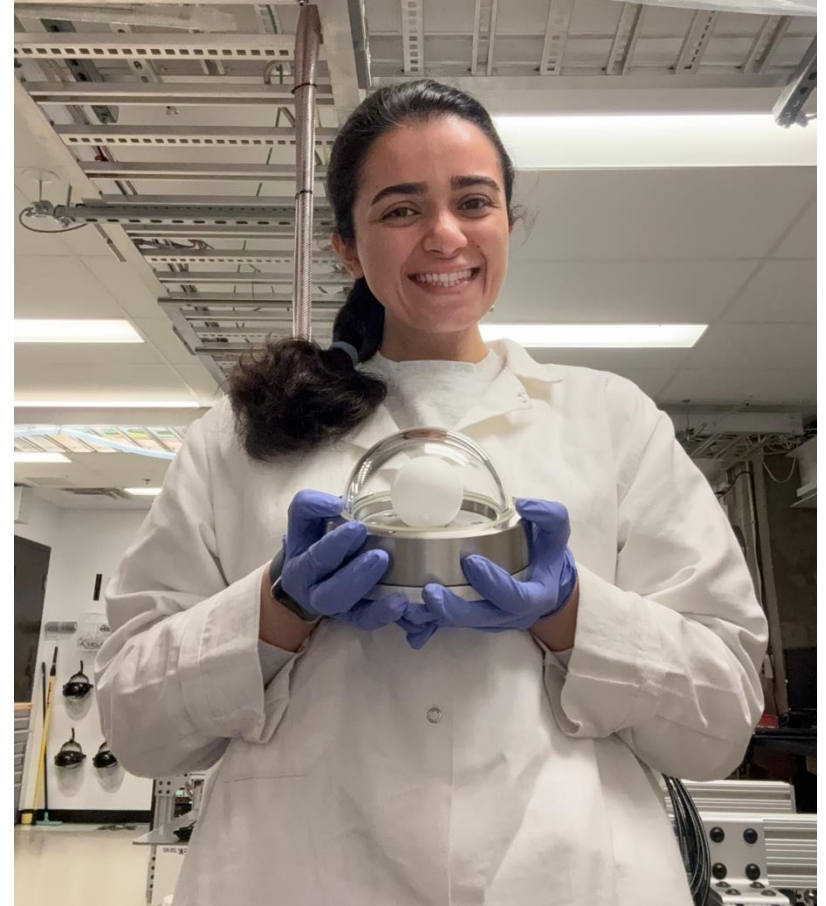

DORY