

# Dark matter detection with skipper-CCDs: latest results and prospects (from SENSEI and OSCURA)

---

**Ana Martina Botti\***  
**SNOLAB User's meeting 2026**  
May 27th, 2026



---

\* Université de Montréal  
ana.martina.botti@umontreal.ca

# Skipper-charge coupled devices (skipper-CCDs)

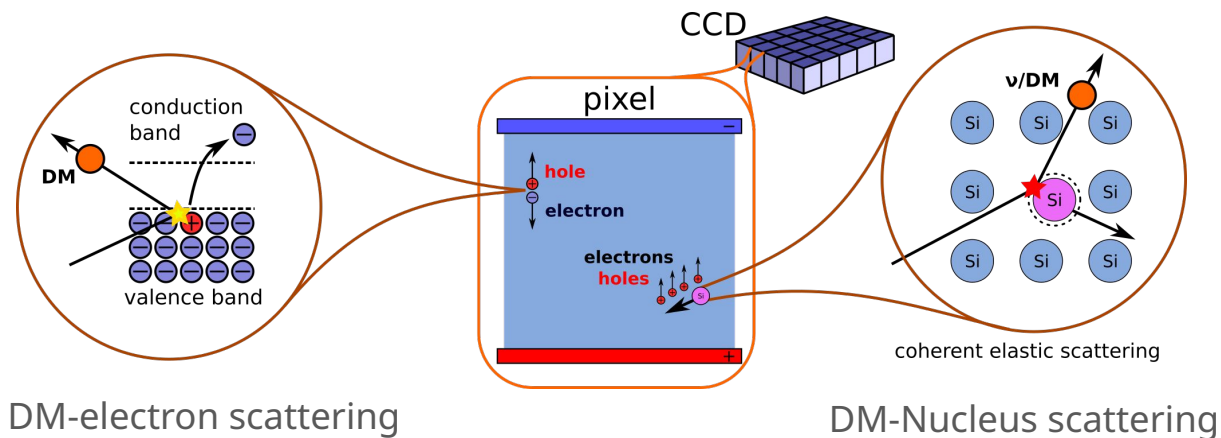

## New amplifier design

Suggested in **1990** by Janesick et al. (doi:10.1117/12.19452)

**Non-disruptive readout:** multiple sampling of same pixel without corrupting the charge packet

Designed at LBNL by S. Holland

CCDs are both a Silicon **target** and a **read-out system**

## Example images (real data!)

Standard CCD

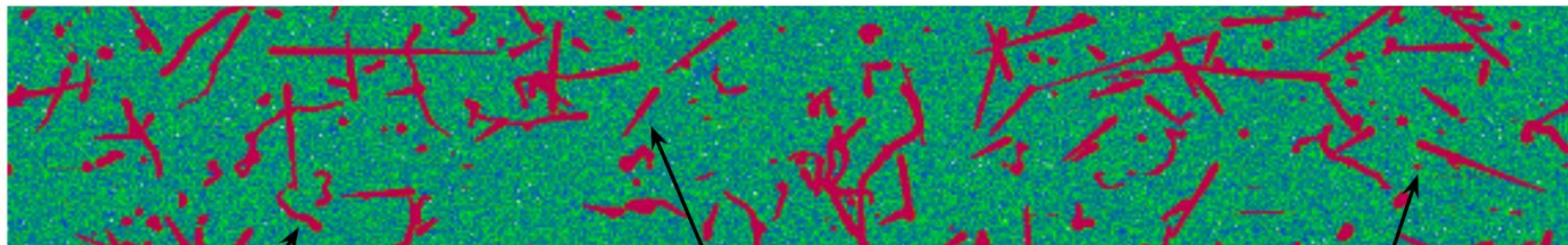

Electrons (curly tracks)

Muons (straight tracks)

X-rays /  $\gamma$ -rays (point-like events)



Skipper- CCD

# Example images (real data!)

Standard CCD

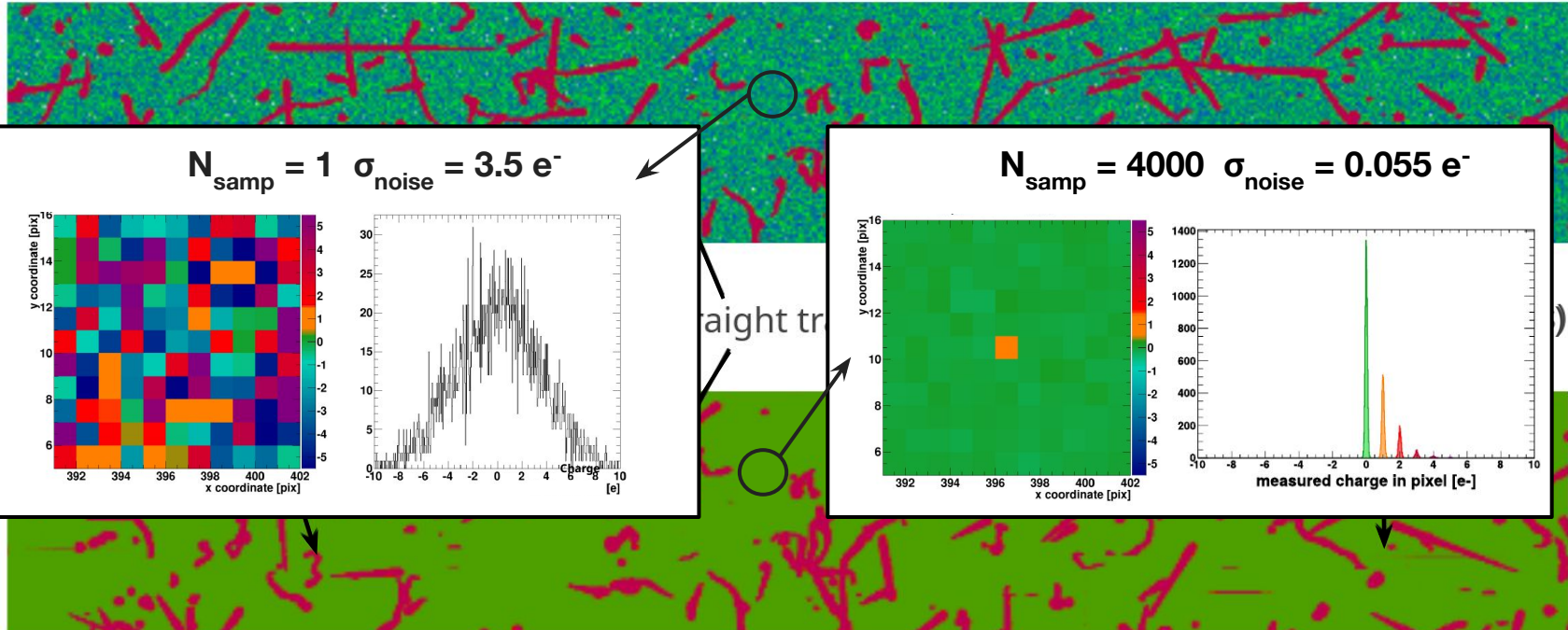

# Skipper-CCDs for dark matter

Light-**DM** mass range:

- 1-1000 MeV for **e<sup>-</sup>** recoil
- 1~1000 eV for **absorption**
- 0.5~1000 MeV **Nucleus** recoil (Migdal effect)

Sensitivity to **1,2,3 e<sup>-</sup>** signals needed: **Skippers** can do this!

But only if we understand and control **backgrounds...**

Expected spectrum from benchmark models (e<sup>-</sup> recoil)

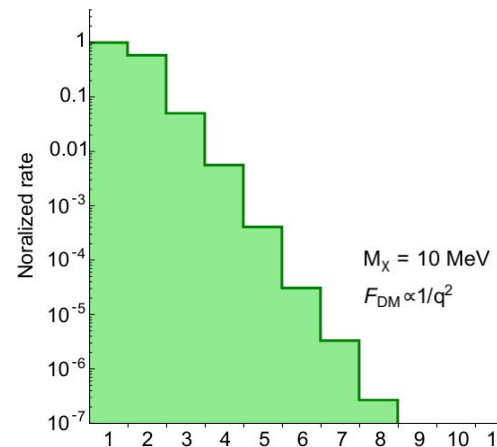

*R. Essig et al, JHEP 05 (2016), 046*

# (Skipper-)CCD experiments for rare-event searches

Halo Dark Matter direct detection  
( $< 1$  GeV mass)



DAMIC



**OSCURA**

Nuclear reactor CEvNS and mCPs



co.VNIe

**VIOLETA**

Dark Matter detection in space

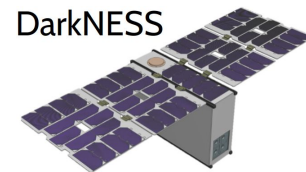

DarkNESS

Beam mCPs

mCP @



**DarkBeats**

**Most of these experiments are or have recently been taking data, with some undergoing upgrades**

# (Skipper-)CCD experiments for rare-event searches

Halo Dark Matter direct detection  
( $< 1$  GeV mass)

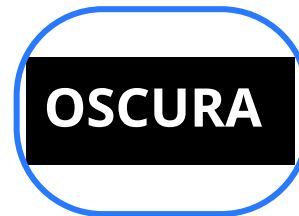
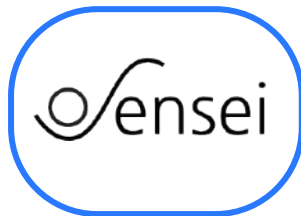

Nuclear reactor CEvNS and mCPs



Dark Matter detection in space

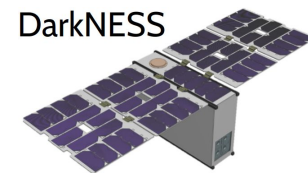

Beam mCPs

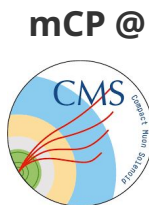

**Most of these experiments are or have recently been taking data, with some undergoing upgrades**

# The Experiment

## Main goals

- **First experiment with Skipper-CCDs**
- **Validate technology for DM and  $\nu$  detection**
- Probe DM masses at the MeV scale (scattering)
- Probe axion and hidden-photon DM masses  $> 1$  eV (absorption)

## Setups

- **Fermilab (MINOS cavern)  $\sim 230$  m.w.e.**
- **SNOLAB  $\sim 6000$  m.w.e.**
- Operating temperature  $\sim 130$  K
- Sensor design at LBNL / integration at FNAL



# The *Sensei* Collaboration



universidad de buenos aires - exactas  
departamento de Física



TEL AVIV  
אוניברסיטת  
UNIVERSITY  
תל אביב

Fully funded by the Heising-Simons foundation & leveraging support from Fermilab



# The Experiment

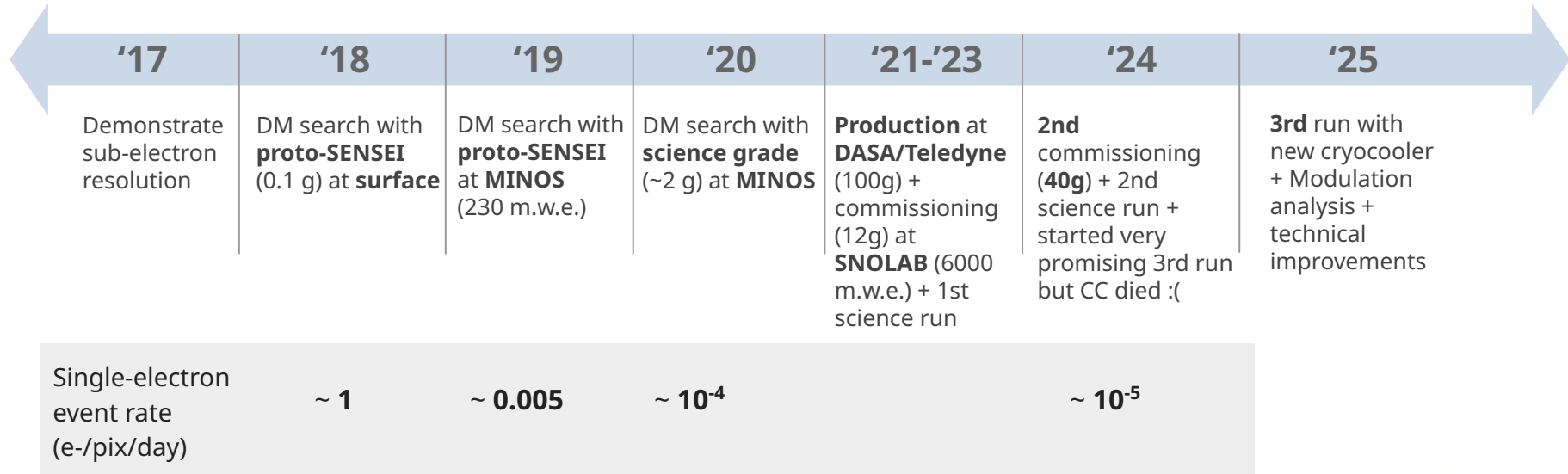

## ACKNOWLEDGMENTS

We thank Andrew Lathrop and our beloved cryocooler (who gave it all until the very end). We are grateful for the support of the Heising-Simons Foundation under



# The Sensei Experiment



De  
sub  
res



2nd  
com  
40g  
scien  
start  
pron  
but

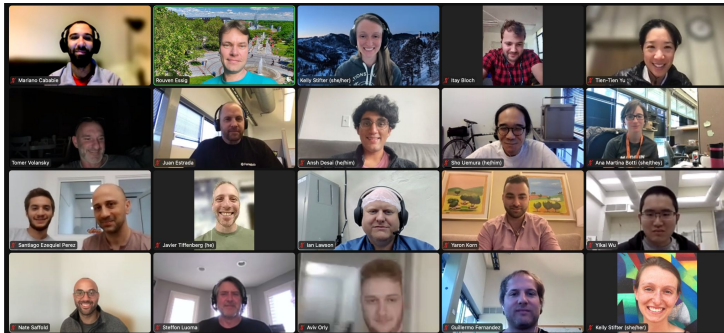
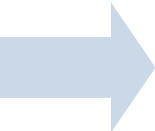
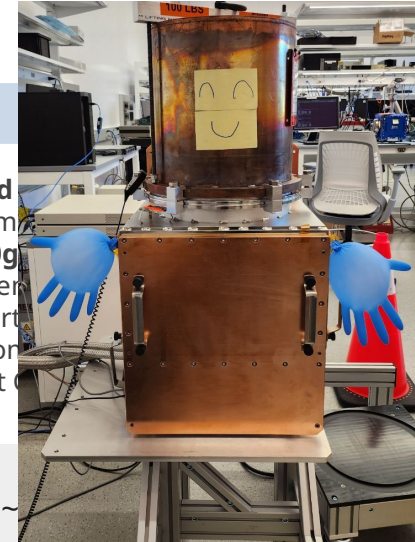

# Current and Latest results: SNOLAB

SENSEI@SNOLAB 2023

Light mediator

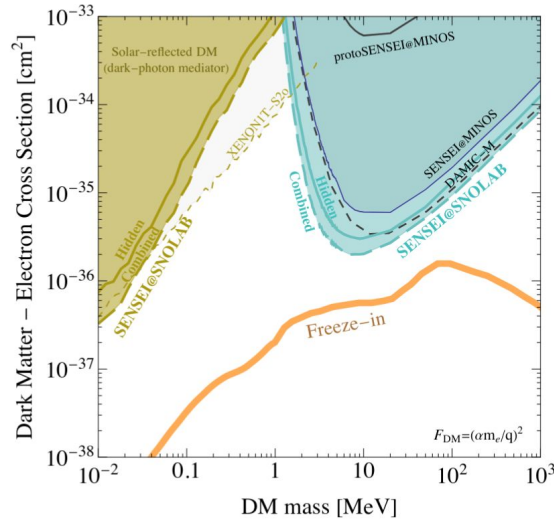

SENSEI@SNOLAB 2024

Light mediator

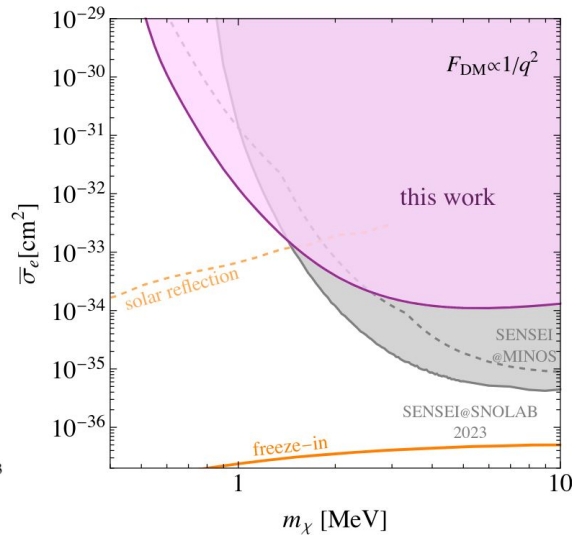

**Keep tuned for results from run 3!**

Phys. Rev. Lett. 121.6 (2018) 061803.  
 Phys. Rev. Lett. 122.16 (2019) 161801  
 Phys. Rev. Lett. 125, 171802 (2020)  
 Phys. Rev. Lett. 134 (2025) 011804  
 Phys. Rev. Lett. 134 (2025) 161002  
 arXiv:2510.20889

- ➔ Numerous advances on Skipper-CCD **operation and single-electron reduction**
- ➔ **Lowest dark current** record (1 e-/pix/200 years)
- ➔ Lowest ever in Silicon (or NIR/UV photodetector)

# Current and Latest results: MINOS

SENSEI@MINOS 2023

Milicharge

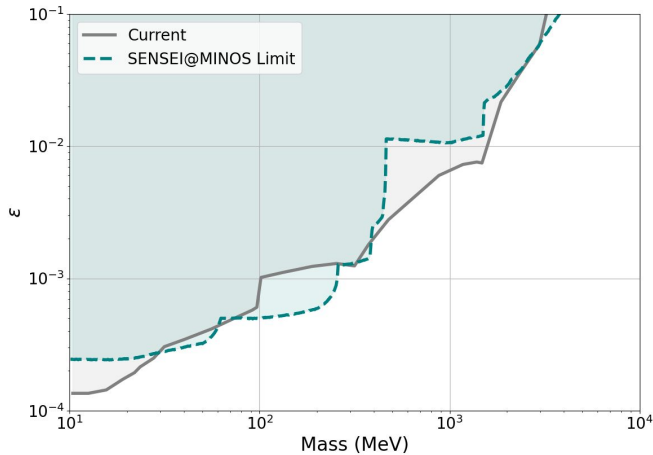

SENSEI@MINOS 2025

Light mediator

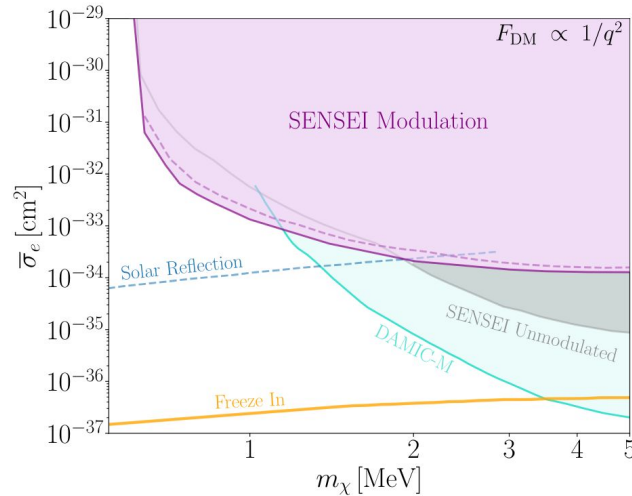

**Two MINOS papers coming soon**

→ Results from MINOS led the way for a new program

Phys. Rev. Lett. 121.6 (2018) 061803.  
 Phys. Rev. Lett. 122.16 (2019) 161801  
 Phys. Rev. Lett. 125, 171802 (2020)  
 Phys. Rev. Lett. 134 (2025) 011804  
 Phys. Rev. Lett. 134 (2025) 161002  
 arXiv:2510.20889

# Open data

Data available in SENSEI papers:

- *Physical Review Letters* 121.6 (2018): 061803.
- *Physical review letters* 122.16 (2019): 161801.
- *Phys. Rev. Lett.* 125, 171802 (2020)
- ***Phys. Rev. Lett.* 133 (2024): 071801**
- ***Phys. Rev. Lett.* 134 (2025), 011804**
- ***arXiv:2410.18716 accepted at PRL***

Contact us if anything else is needed

Shape	All data			Hidden data		
	Expo.	Ev.	Bkgd.	Expo.	Ev.	Bkgd.
2e2p, h	13.58	10	10.66	6.12	6	4.75
2e2p, v	16.21	13	12.65	<b>7.36</b>	6	5.61
2e2p, d	17.82	32	25.31	7.65	18	11.22
<b>2e, all</b>	<b>46.61</b>	<b>55</b>	<b>48.62</b>	<b>21.13</b>	<b>30</b>	<b>21.57</b>
3e2p	30.87	3	0.01	14.01	2	0.01
3e3p	26.84	1	0.06	12.21	0	0.03
<b>3e, all</b>	<b>57.71</b>	<b>4</b>	<b>0.07</b>	<b>26.22</b>	<b>2</b>	<b>0.03</b>
4e2p	19.51	0	0.00	8.85	0	0.00
4e3p	27.60	0	0.00	12.55	0	0.00
4e4p	15.93	0	0.00	7.25	0	0.00
<b>4e, all</b>	<b>63.03</b>	<b>0</b>	<b>0.00</b>	<b>28.66</b>	<b>0</b>	<b>0.00</b>
5e, all	65.56	0	0.00	29.84	0	0.00
6e, all	67.31	0	0.00	30.63	0	0.00
7e, all	68.53	0	0.00	31.19	0	0.00
8e, all	69.52	0	0.00	31.67	0	0.00
9e, all	70.30	0	0.00	32.02	0	0.00
10e, all	70.89	0	0.00	32.30	0	0.00

# Skipper-CCD program @ underground labs

SENSEI 100g

DAMIC-M 1kg

OSCURA 10kg



Current

Projected

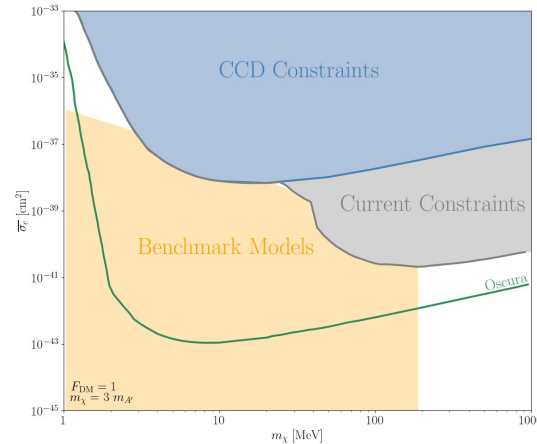
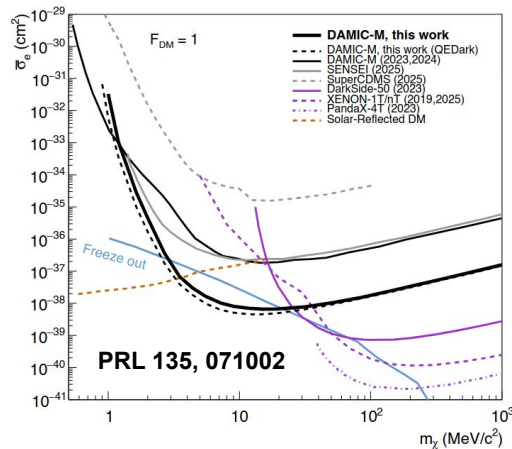

- We are pushing towards  $10^{-2}$  more mass and  $10^{-2}$  less backgrounds.
- **Oscura** will have be ultimate DM skipper-CCD detector, **joining expertise from all ongoing efforts.**

# OSCURA Collaboration



**BERKELEY LAB**  
Bringing Science Solutions to the World



Pacific Northwest  
NATIONAL LABORATORY



JOHNS HOPKINS  
UNIVERSITY



Stony Brook  
University



UNIVERSITY of  
WASHINGTON



THE UNIVERSITY OF  
CHICAGO



UNIVERSITY OF  
OREGON



Brookhaven  
National Laboratory



Comisión Nacional  
de Energía Atómica



universidad de buenos aires - exactas  
departamento de Física  
Juan José Giambiagi

ICAS



Instituto de Física de Cantabria



UNIVERSIDAD  
NACIONAL  
DEL SUR



TEL AVIV  
אוניברסיטת  
תל אביב  
UNIVERSITY



# From SENSEI to OSCURA

We need to scale to 10 kg

## SENSEI:

- 200 channels / 50 CCDs
- 1 Low-threshold acquisition board / 1 CCD
- 1 Silicon pitch adapter / CCD

## OSCURA:

- ✓ 24000 channels / 24000 CCDs
- ✓ 1 Low-threshold acquisition board + ACDS and mux in ASIC / 4000 CCDs
- Current OSCURA electronics can read whole 125g with 1 channel and whole 2 kg with 1 board*
- ✓ 1 Silicon pitch adapter / 16 CCDs

More than 600 sensors packaged and tested  
Vessel to be demonstrated  
Assembly plan is challenging

IEEE Transactions vol. 70, no. 6, pp. 2306-2316  
JINST 18 P01040 arxiv:2004.07599  
JINST 16 P11012 IEEE Sensors,25, 5, 8813-8822

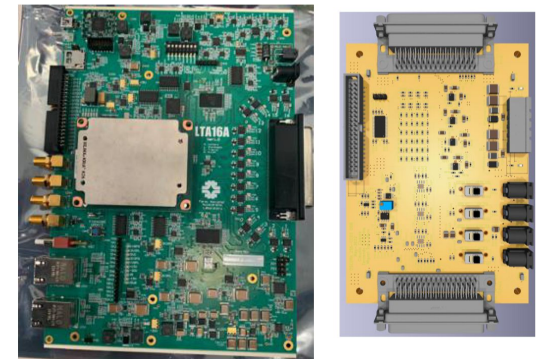
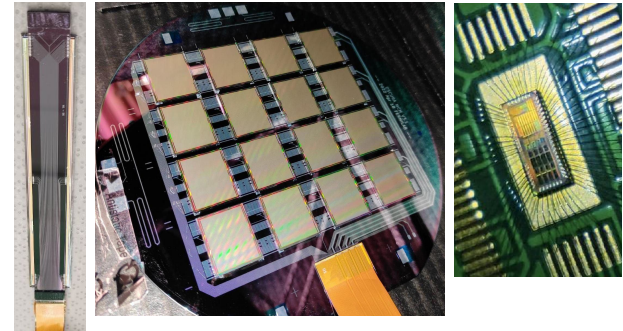



# Looking forward:

Dark matter search with CCDs: successful example of **synergy** between fields and **science** with **industry**.

The detector systems for the Spec-S5 spectrographs will utilize novel multi-amplifier sensing (MAS) CCDs (Figure 13) (Holland 2023; Botti et al. 2024) that leverage the non-destructive floating gate readout amplifier system developed for ultra-low-noise Skipper CCDs (Tiffenberg et al. 2017). These detectors have been demonstrated to produce dramatically lower read noise ( $< 1 e^- \text{ rms pix}^{-1}$ ) (Botti et al. 2024) than the current DESI CCDs (Bebek **The Spectroscopic Stage-5 Experiment arxiv:2503.07923**)

demonstrations using fully depleted, p-channel, Skipper CCDs by multiple groups. Skipper is one of two photon counting p-channel CCD architectures that we have explored. The other is the hole multiplying CCD (HMCCD). We stopped working on HMCCDs about a year ago after discovering that their use of impact ionization for charge multiplication had undesirable side effects. This article provides a snapshot of our plans for Skipper going forward **NASA future exoplanet and x-ray. SPIE Proceedings, Volume 12180, id. 1218065 12 pp. (2022).**

## Astro / Imaging

- New readout architectures to speed up → Dark matter / neutinos
- Advancements in fabrication for larger sensors → reduce background pile-up
- Cooler sensors (no polysilicon) → mass scalability
- IR technologies (germanium and doped silicon) → reduced dark current
- Dual side processing → Lower energy threshold
- System integration, operation, etc. → remove surface backgrounds

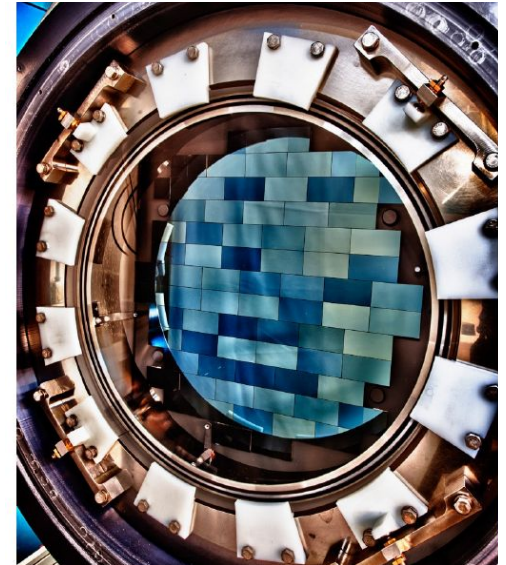

*Decam focal plane*

# Group and lab at UdeM

New **lab** and **hub** for CCD-like sensor **R&D** and **low-background experiments** (strategic location, close to **DALSA** and **SNOLAB**).

Opportunities for interdisciplinary efforts with **Astro**, **Quantum**, **Condense matter**, etc.

**NSERC** support (**UdeM+SNOLAB**) for **SENSEI/OSCURA**: may include deploying **OSCURA** sensors in **SNOLAB**, testing new DAQ ideas, fostering **DAMIC/SENSEI/DAMIC-M collaboration**, develop **analysis** and **simulation** tools, etc.

**MI** support for two **MSc students** (**SENSEI** data analysis started Jan 26 + **OSCURA** sensor characterization starting this summer).

1 **CCD system** at **UdeM** (Fermilab loan); seeking funding to expand to 4 testing stations:

- SENSEI/OSCURA
- Astronomy / quantum imaging
- X-ray detection
- Fundamental measurements of silicon properties (leverage LTA beam)



# Summary

**Many efforts for rare-event searches with CCDs. Skipper-CCDs are a demonstrated leading technology. New technologies will improve sensitivity.**

- 1e- rate record of  $(1.4 \pm 0.1) \times 10^{-5}$  e-/pix/day
  - Limit with **MINOS** data for **mCP**. **Best constraints around 100 MeV.**
  - Best constraints from **SNOLAB** on **DM-e- direct scattering** for **light mediator (~1 MeV)**, and **Absorption (~ 3 eV)**
  - **New cryocooler** installed in **SNOLAB**
  - **Modulation** analysis out
- Results on **fundamental operation parameters** also coming soon
  - **New** data with different exposures to study **2, 3, 4 e- channels** with improved analysis coming soon
  - **Strategies to further push background** foreseen: different form factor, package, IR shield, etc
  - **generations of skipper-CCD experiments** foreseen for cosmic DM searches
  - **New** canadian support to advance the program

# Charge-coupled devices (CCD)

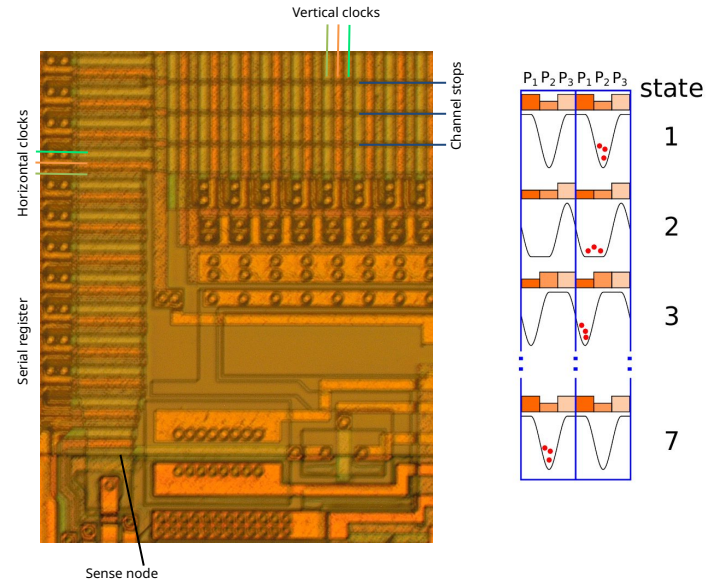
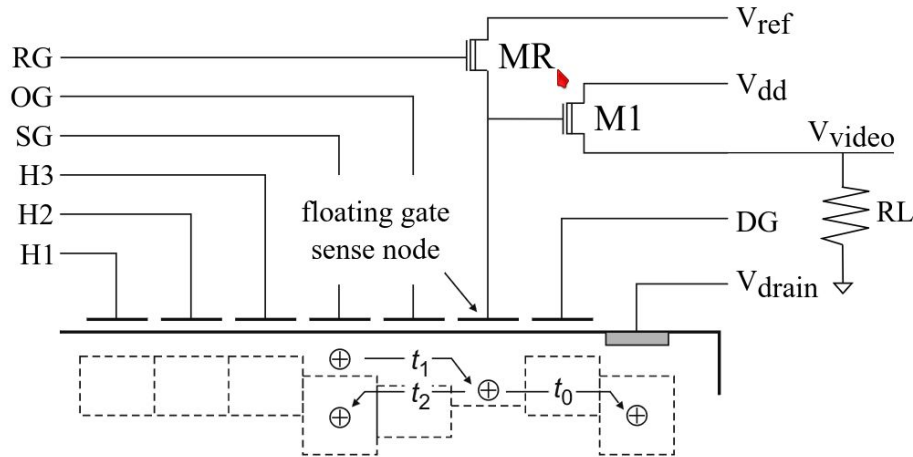

# To bluer skies: a dual-side CCD

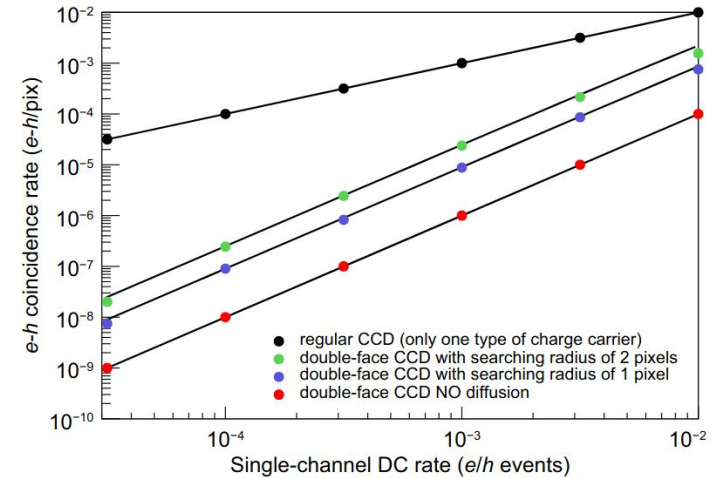
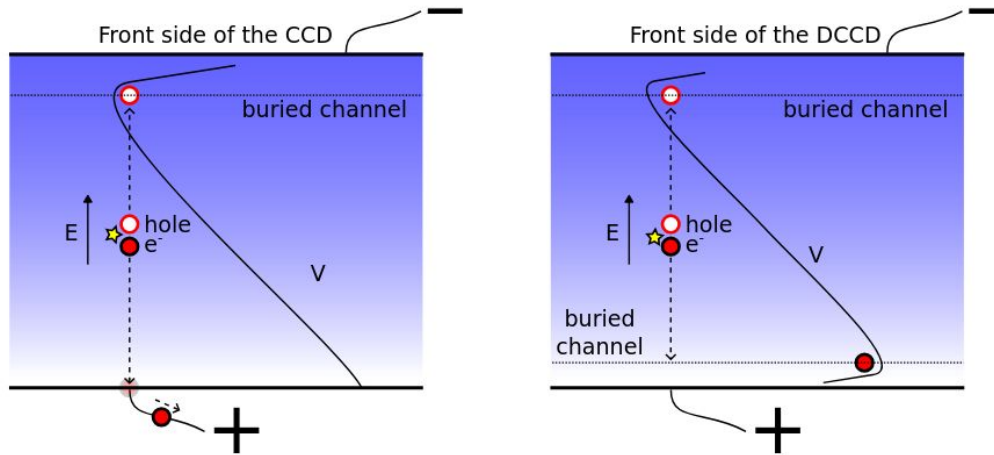

# To bluer skies: a dual-side CCD

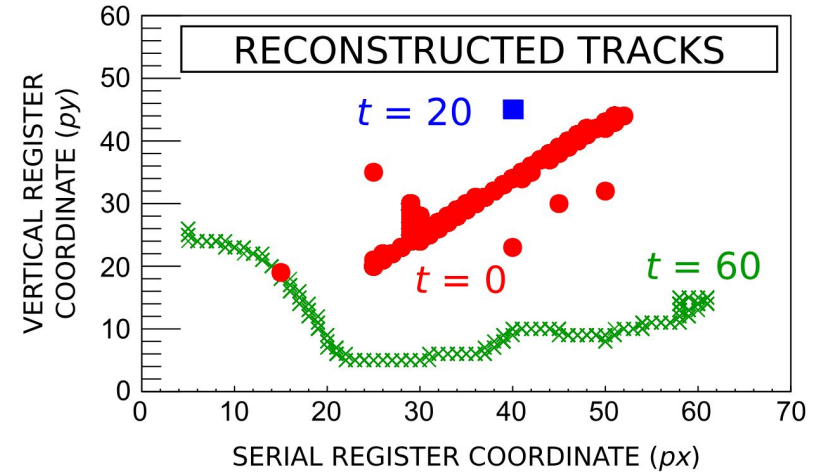
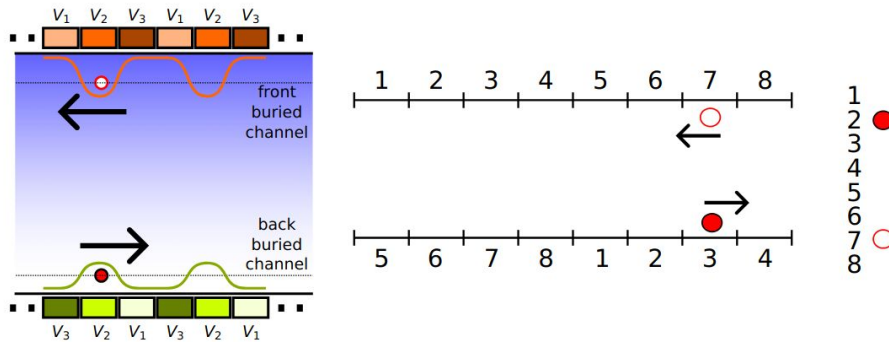

**Skipper-CCDs were once a blue sky idea**

# Background goal

DC (e-/pix/day)

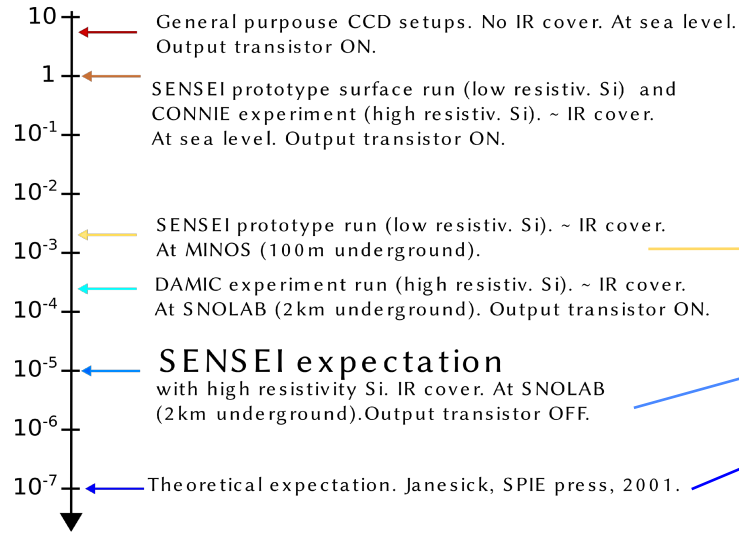

Dark Current [e <sup>-</sup> pix <sup>-1</sup> day <sup>-1</sup> ]	≥ 1e <sup>-</sup> [pix]	≥ 2e <sup>-</sup> [pix]	≥ 3e <sup>-</sup> [pix]
→ $10^{-3}$	$1 \times 10^8$	$3 \times 10^3$	$7 \times 10^{-2}$
→ $10^{-5}$	$1 \times 10^6$	$3 \times 10^{-1}$	$7 \times 10^{-8}$
→ $10^{-7}$	$1 \times 10^4$	$3 \times 10^{-5}$	$7 \times 10^{-14}$

Background estimations for 1 year and 100 g.

**Blue:** discovery channel (background free)  
**Red:** modulation or limits

# 2023: Milli-charged particles (mCPs) @ MINOS

Proton collisions w/ fixed target -> mCPs collinear w/ NuMI beamline:

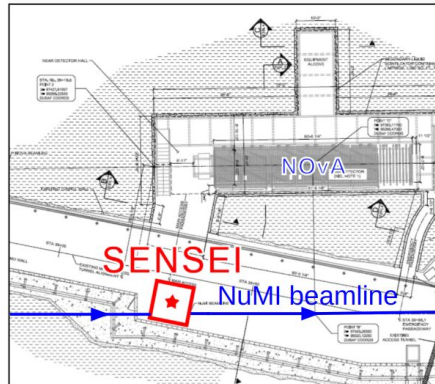
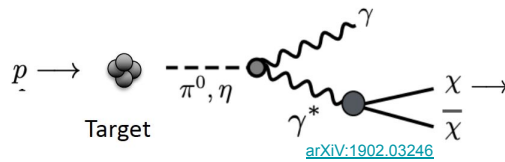

Extension of previous analysis to  $6e^-$

	$1e^-$	$2e^-$	$3e^-$	$4e^-$	$5e^-$	$6e^-$
Efficiency	0.069	0.105	0.325	0.327	0.331	0.338
Exp. [g-day]	1.38	2.09	9.03	9.10	9.23	9.39
Obs. Events	1311.7	5	0	0	0	0

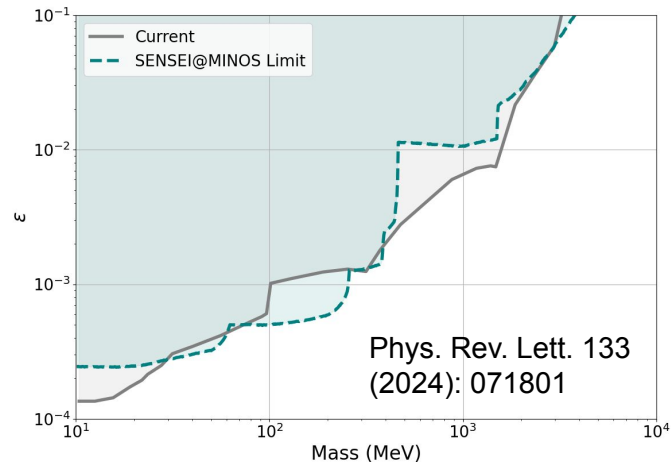

# mCPs at Beams

- Fermilab LDRD support for tracker at NuMI
- SENSEI CCD deployed and taking data at miliQan cavern at LHC since 2023

Prospects of 1 kg skipper-CCD instrument @ NuMI, PIP-II, HL-LHC, JLAB

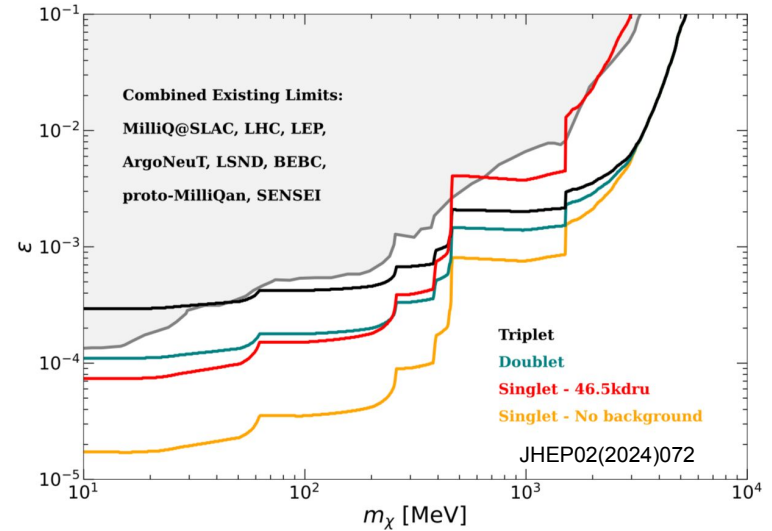

Credits: B. Cervantes, S. Perez, C. Chavez

# DarkNESS

## 6U CubeSat:

- 1.3 Mpix skipper-CCD
- 4 channel package
- New SENSEI compact electronics

## Science goal:

- Search **3.5 keV X-ray** in galaxy cluster observed by XMM (*Bubul et al 2014*)
- Search for **SIMPs modulation**

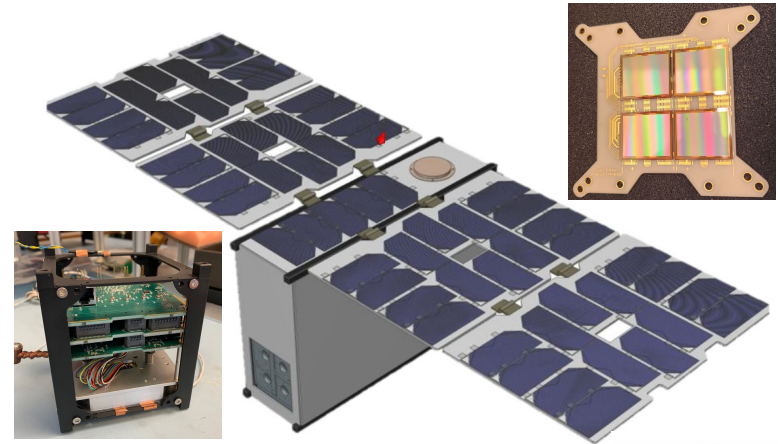

Funded by the **Heising-Simons** foundation, R&D from **Fermilab & UIUC** and launch by **Firefly Aerospace**



# DarkNESS projected sensitivities

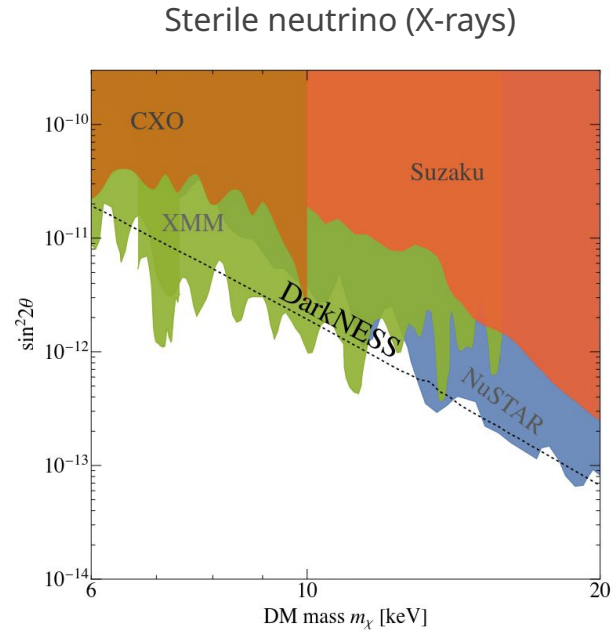
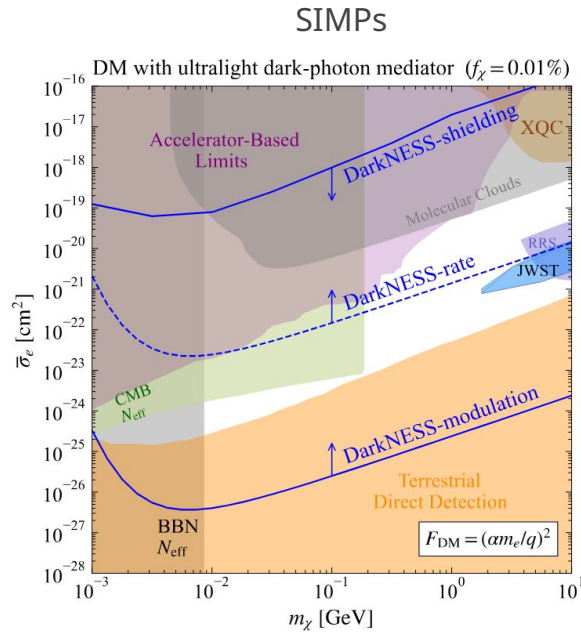

arxiv:2505.16981

# Standard CCD readout

CCDs are both a Silicon **target** and a **read-out system**

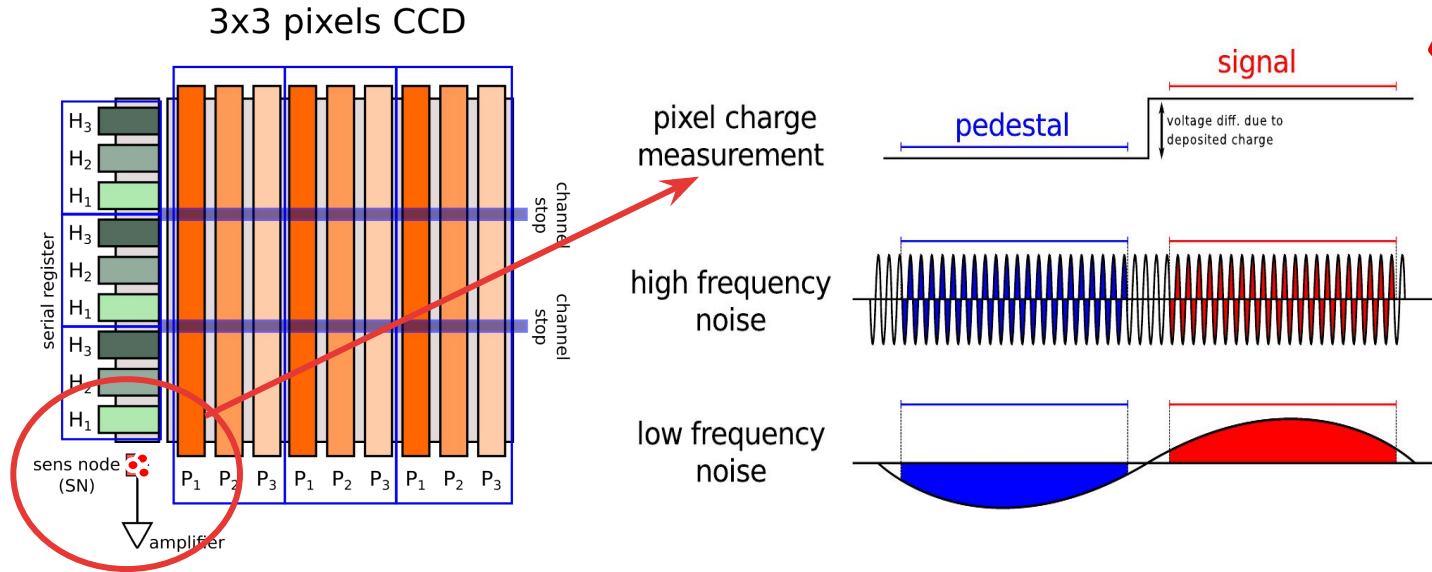

If  $\Delta t > 2 / f_{\text{noise}}$  the noise is suppressed

Standard CCD read-out can suppress high-frequency noise, but not low-frequency...

# The Experiment

Light mediator

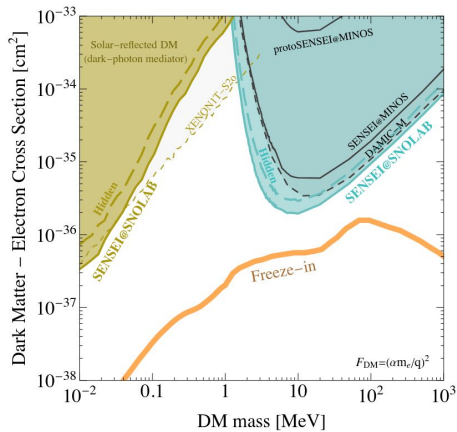

Heavy mediator

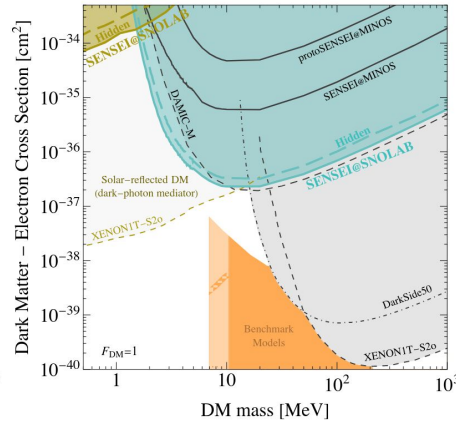

Heavy mediator (migdal)

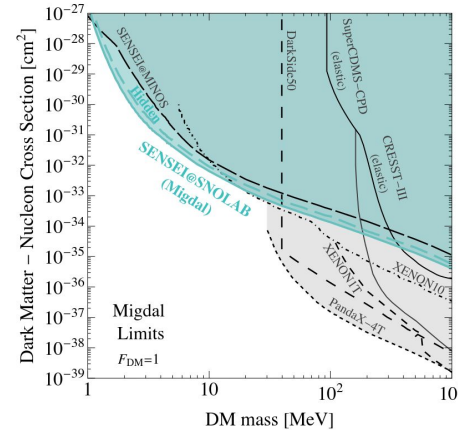

Absorption

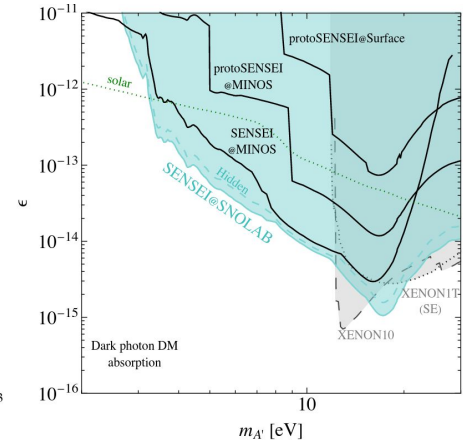

Phys. Rev. Lett. 121.6 (2018) 061803.  
 Phys. Rev. Lett. 122.16 (2019) 161801  
 Phys. Rev. Lett. 125, 171802 (2020)  
 Phys. Rev. Lett. 134 (2025) 011804  
 Phys. Rev. Lett. 134 (2025) 161002

- Numerous advances on Skipper-CCD **operation and single-electron reduction**
- **Lowest dark current** record (1 e-/pix/200 years)
- Lowest ever in Silicon (or NIR/UV photodetector)

# OSCURA configuration

