

04/17/2026

# Alpha Decay in Spherical Proportional Counters

---

Alyssa Sanden

# The Radon Decay Chain

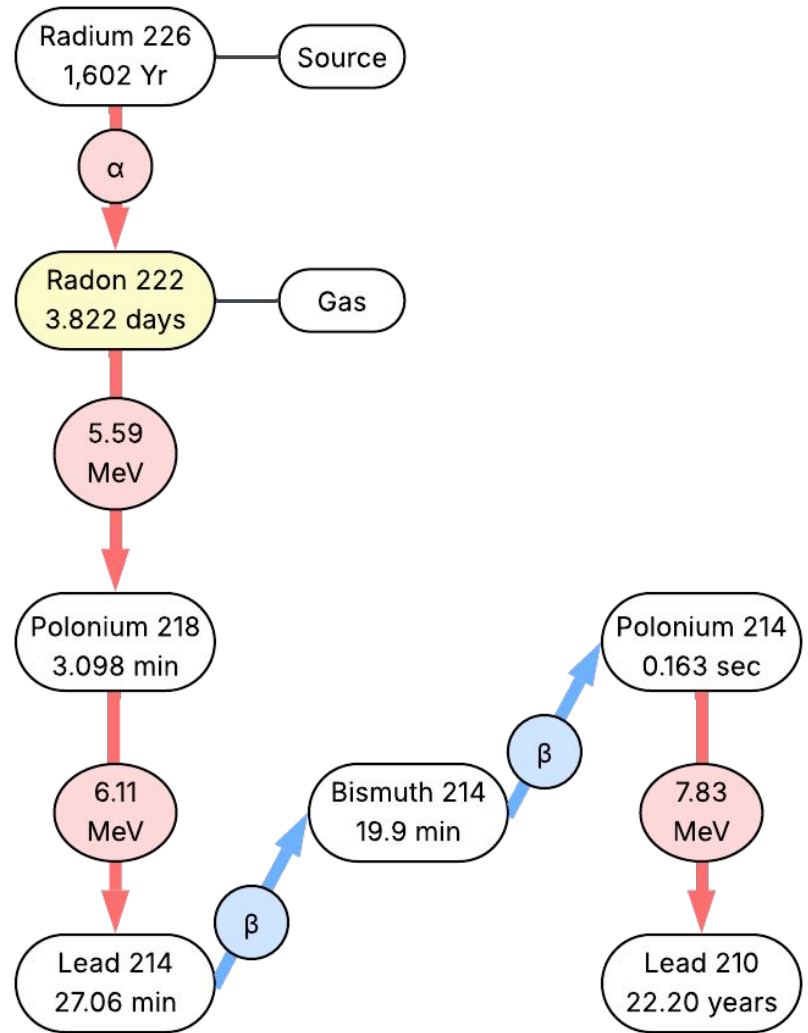
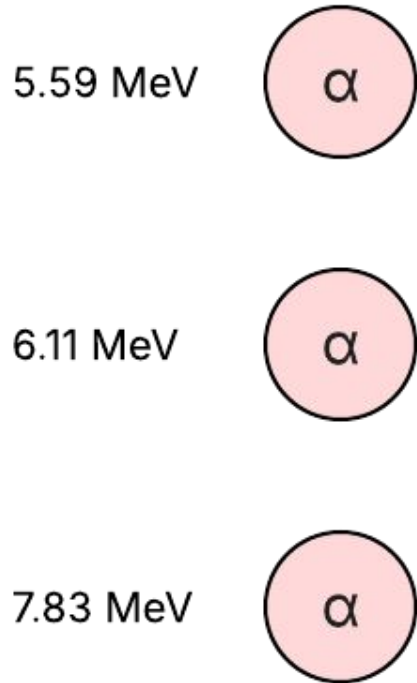

# Benefits of a spherical proportional counter

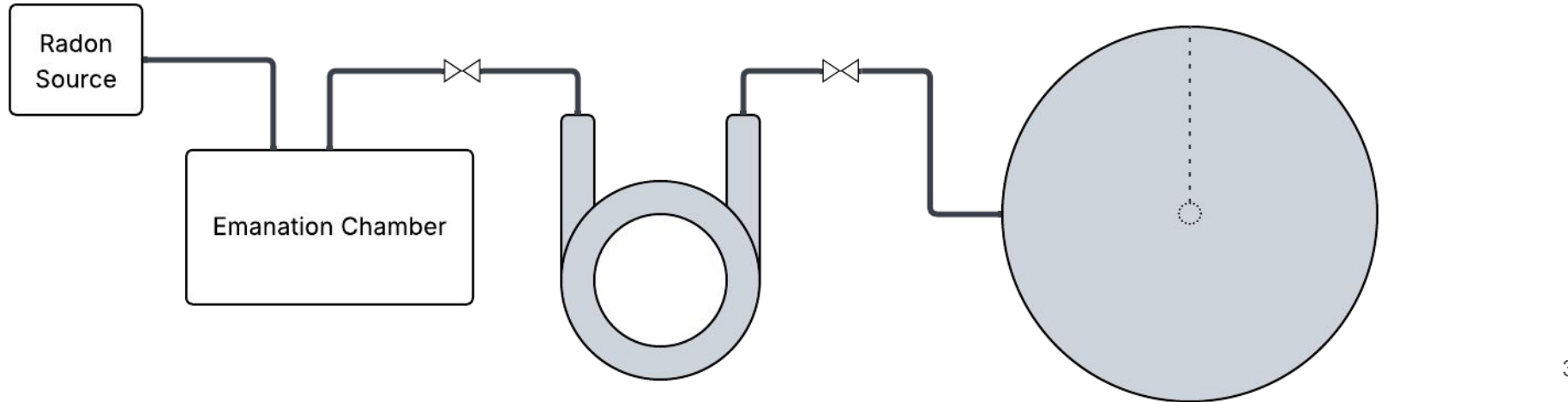
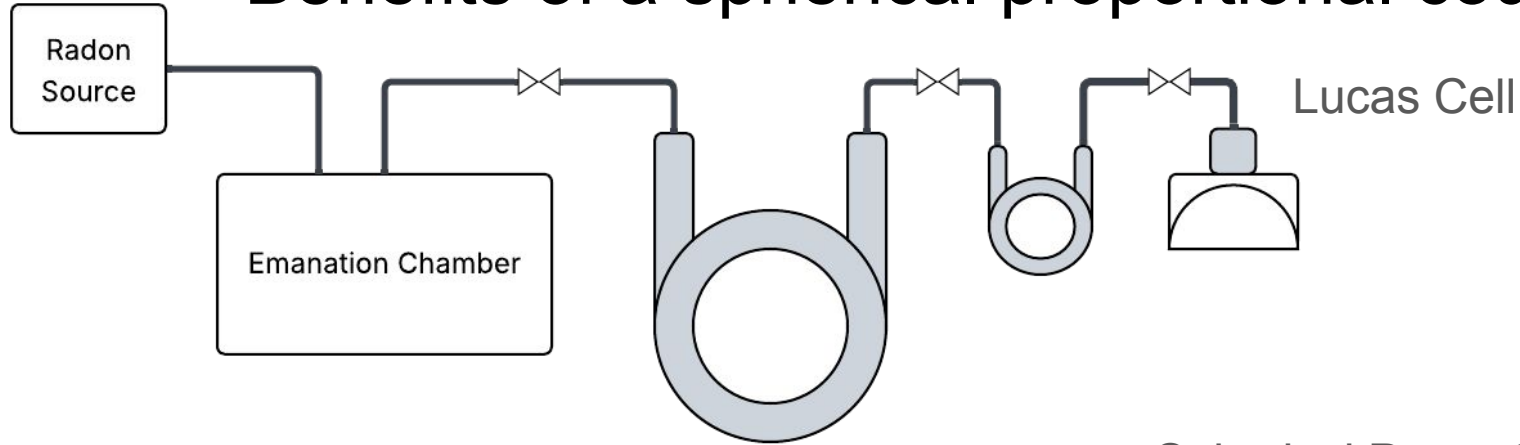

# Sphere Composition

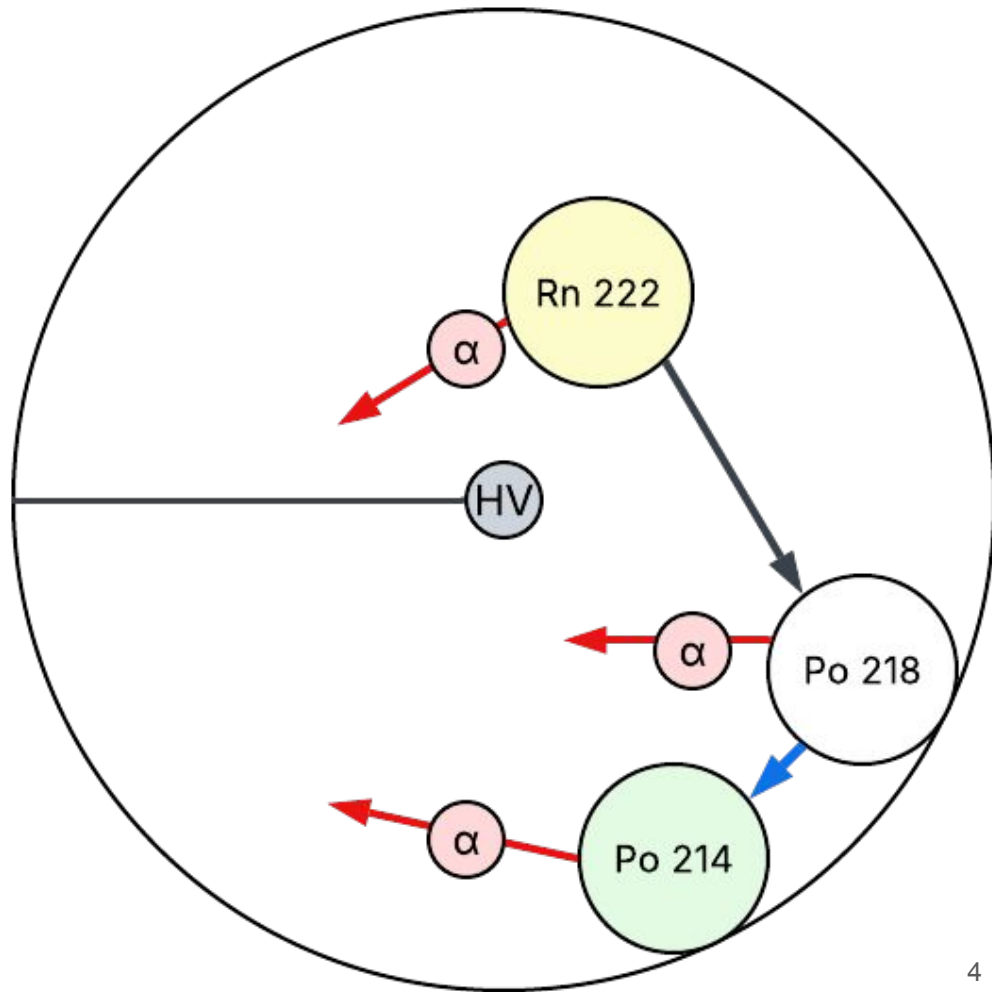
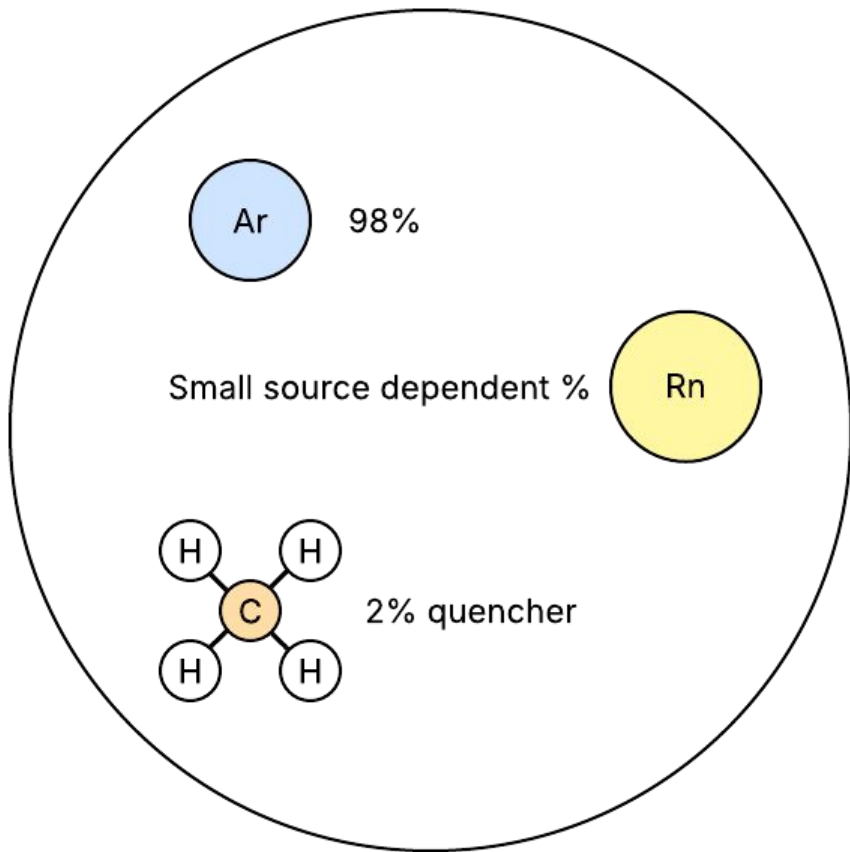

# Types of Alpha Interactions

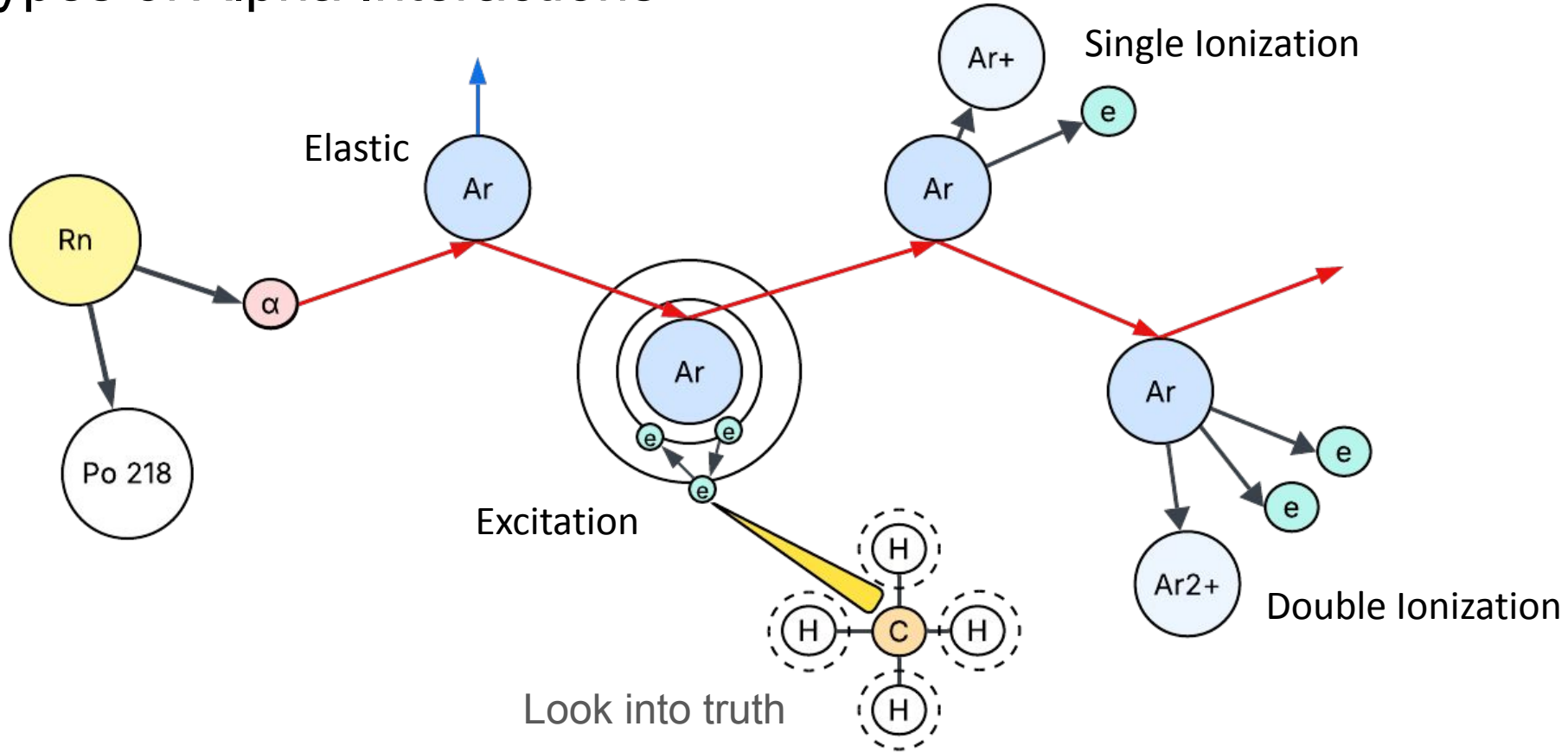

# High Voltage and Townsend Region

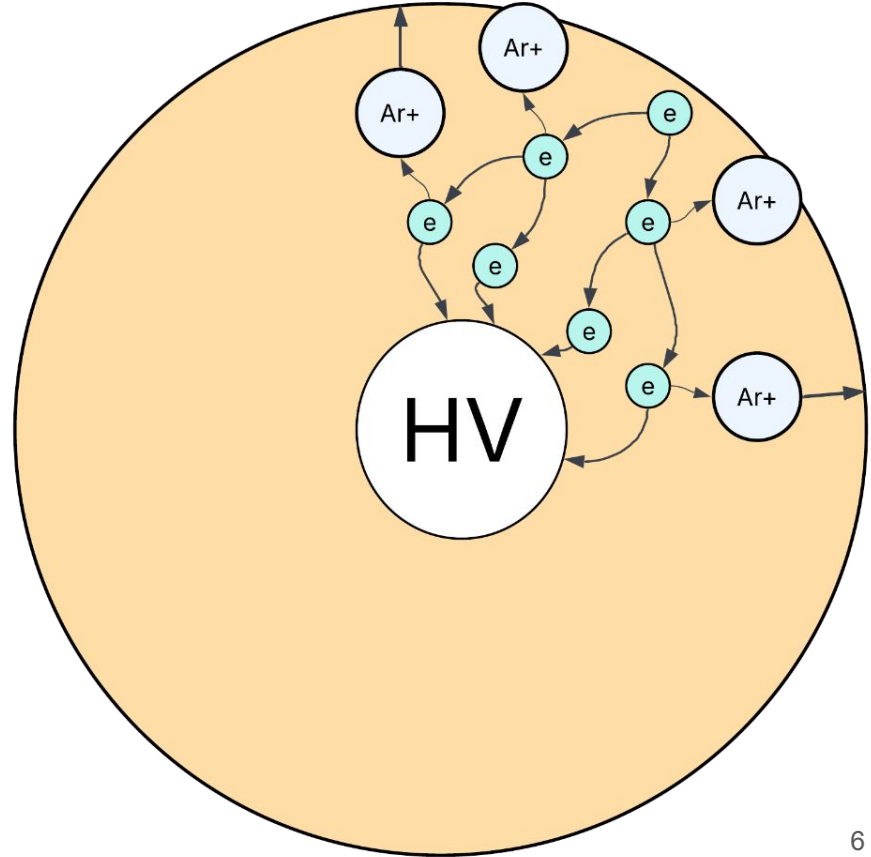
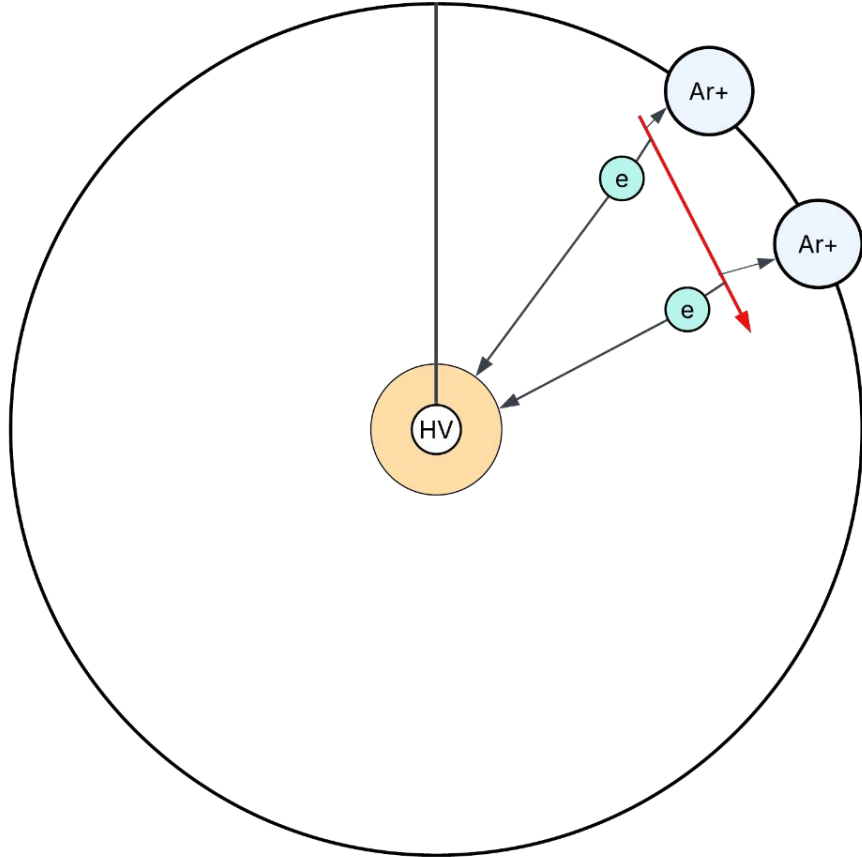

# Amplification

High Voltage

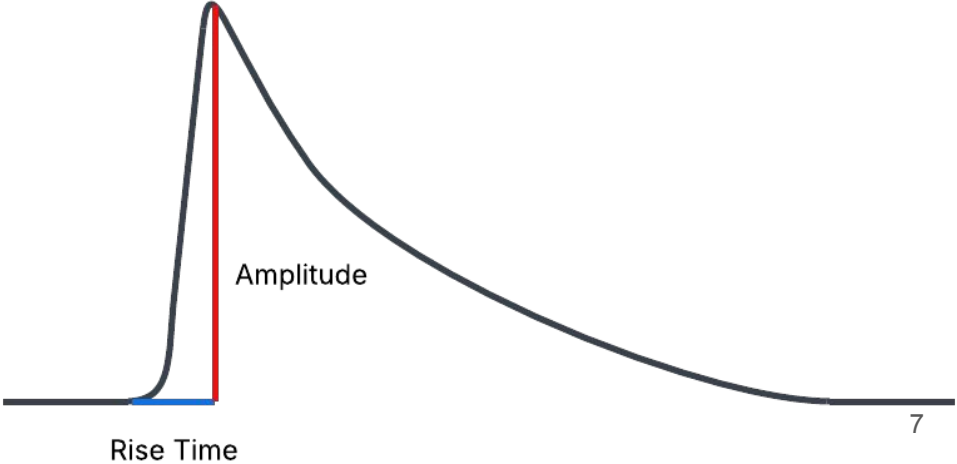
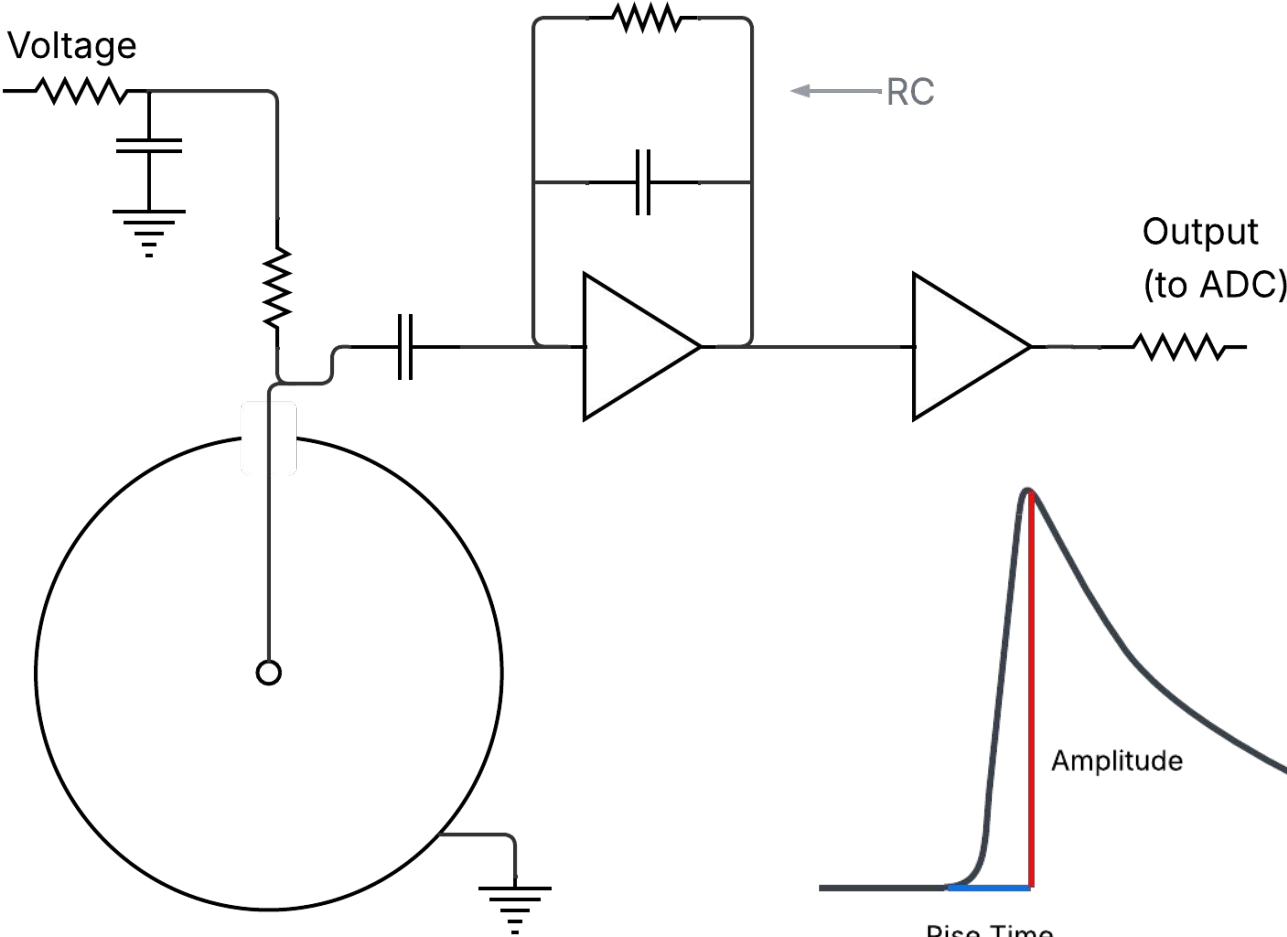

Can you use a spherical proportional detector to count the radon emitted from a source?

# Engineering Improvements

- Radon source
- Fixed computer with new hard drive
- Changed HV power supply
- New mount for amplifier
- Noise reduction methods
- Midas software for power supply control and monitoring
- Integration of computer and analog to digital converter
- Network setup for remote access
- Attached new spheres
- So much leak checking
- Heater circuit

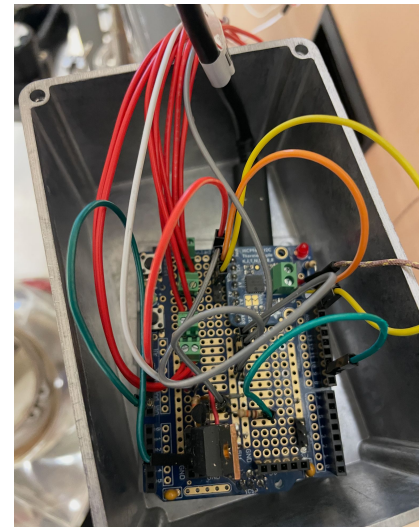

# First Data: No Radon?

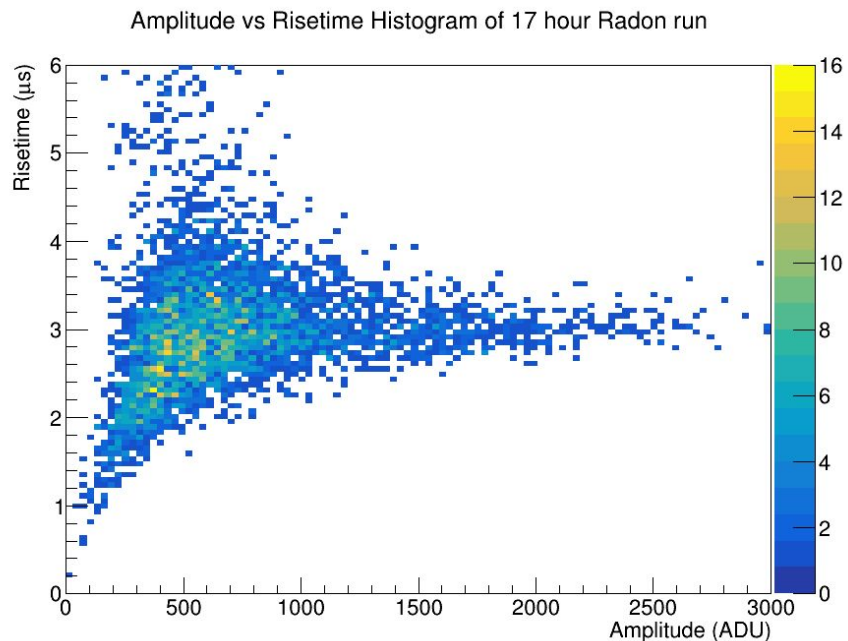

5.59 MeV

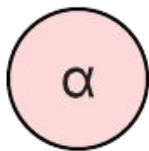

6.11 MeV

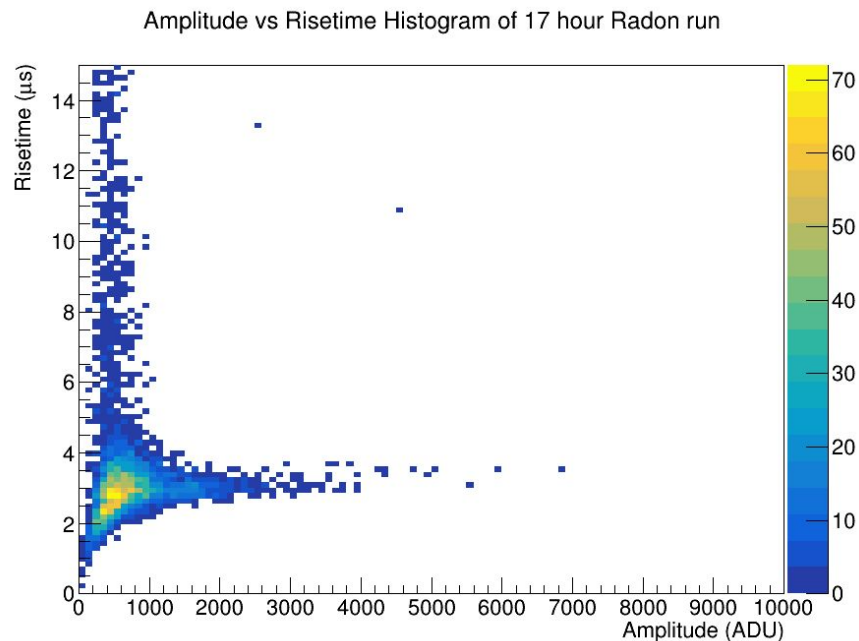
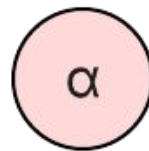

7.83 MeV

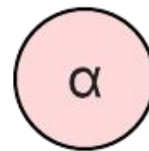

# Simulation Data

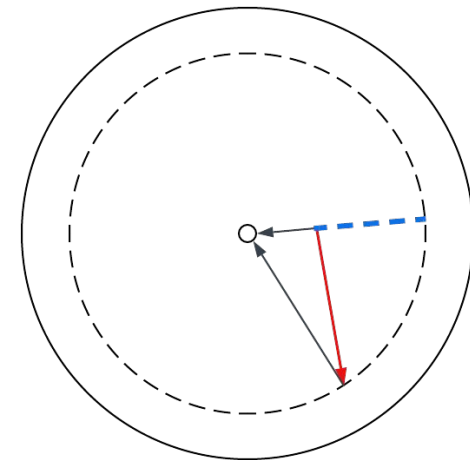
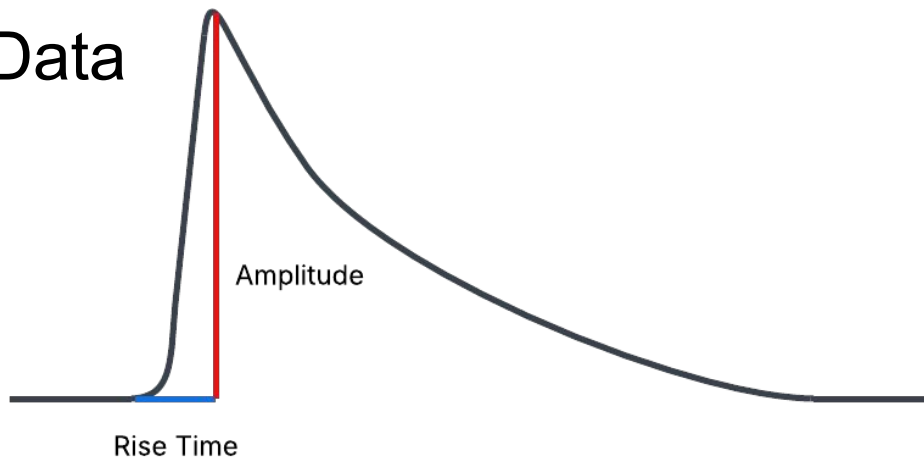

Energy Deposited in Gas by Particle

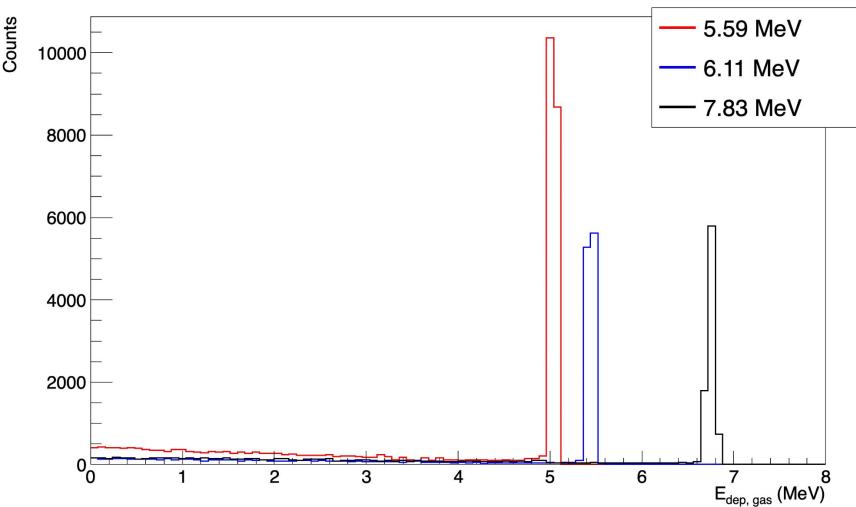

$R_{\text{max}}^3 - R_{\text{min}}^3$  by Energy

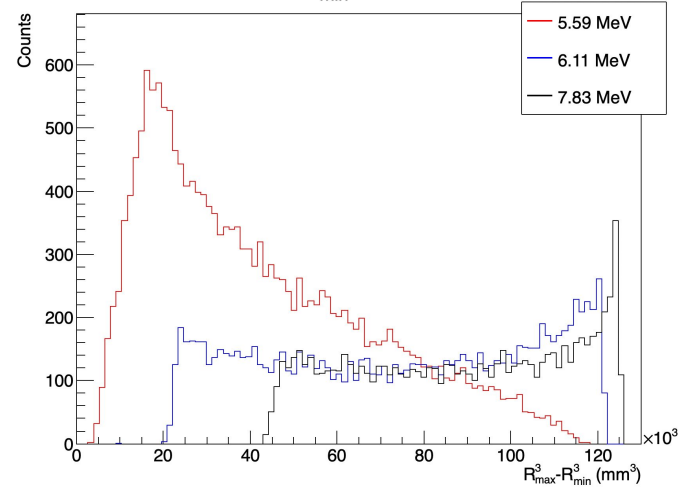

# Find Radon?



Amplitude vs Risetime Histogram of 17 hour Radon run

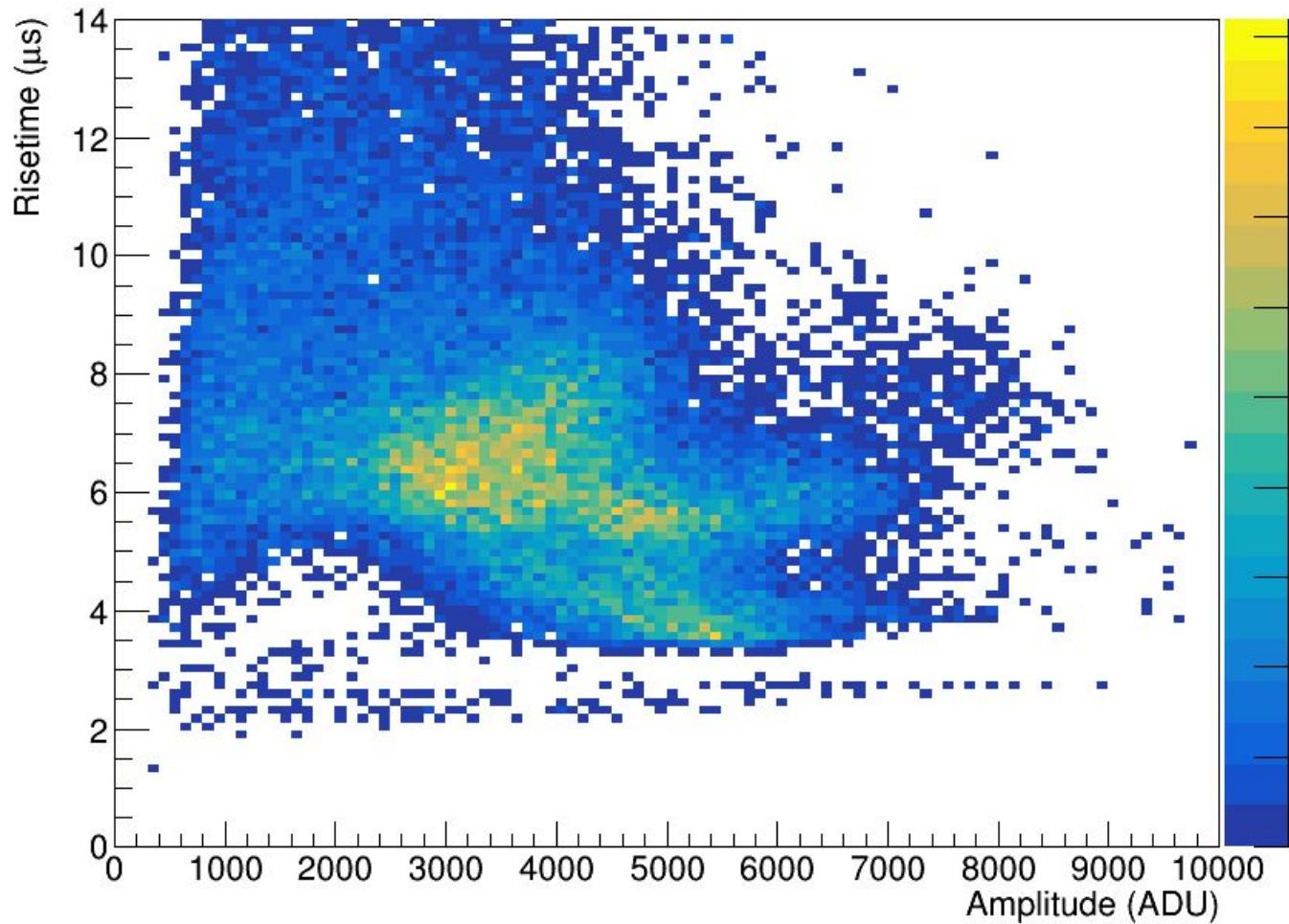

# Radon Event Identification

Amplitude vs Risetime Histogram of 17 hour Radon run

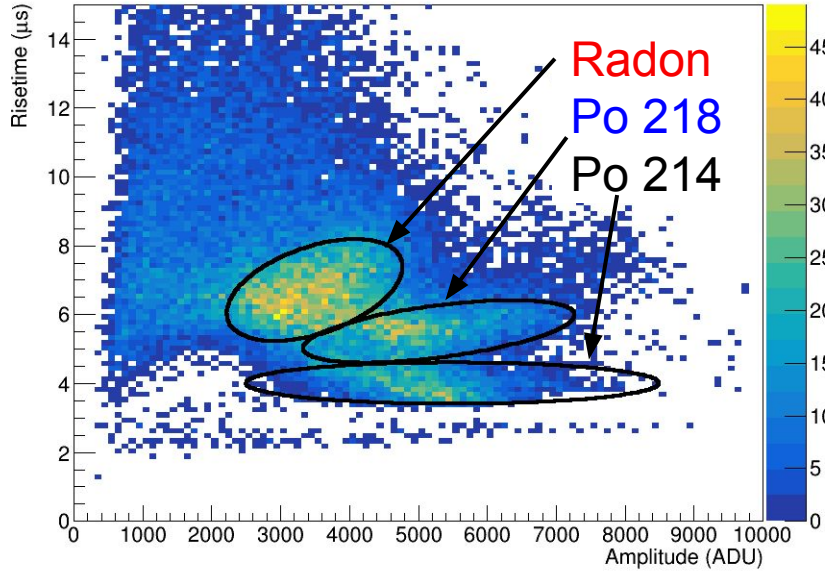

Event counts inside each ellipse:

ellipse1: 8804

ellipse2: 5036

ellipse3: 3480

**1** : **0.57** : **0.40**

Distance of Alpha Particle Track in Gaseous Volume

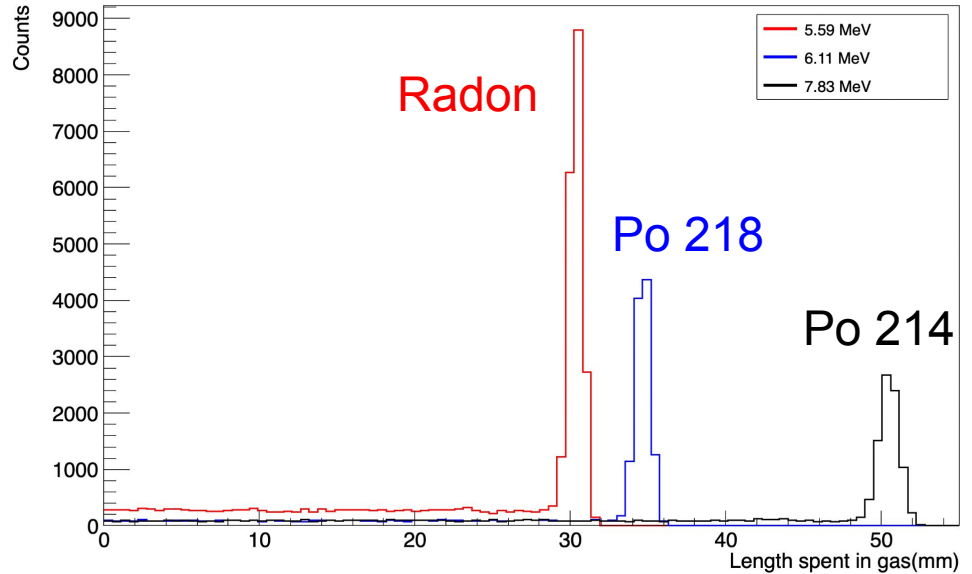

Area under curve

- 5.59 MeV → ~ 10580
- 6.11 MeV → ~6061
- 7.83 MeV → ~4661

**1** : **0.57** : **0.44**

# Further Confirmation

Amplitude vs Risetime Histogram of 17 hour Radon run

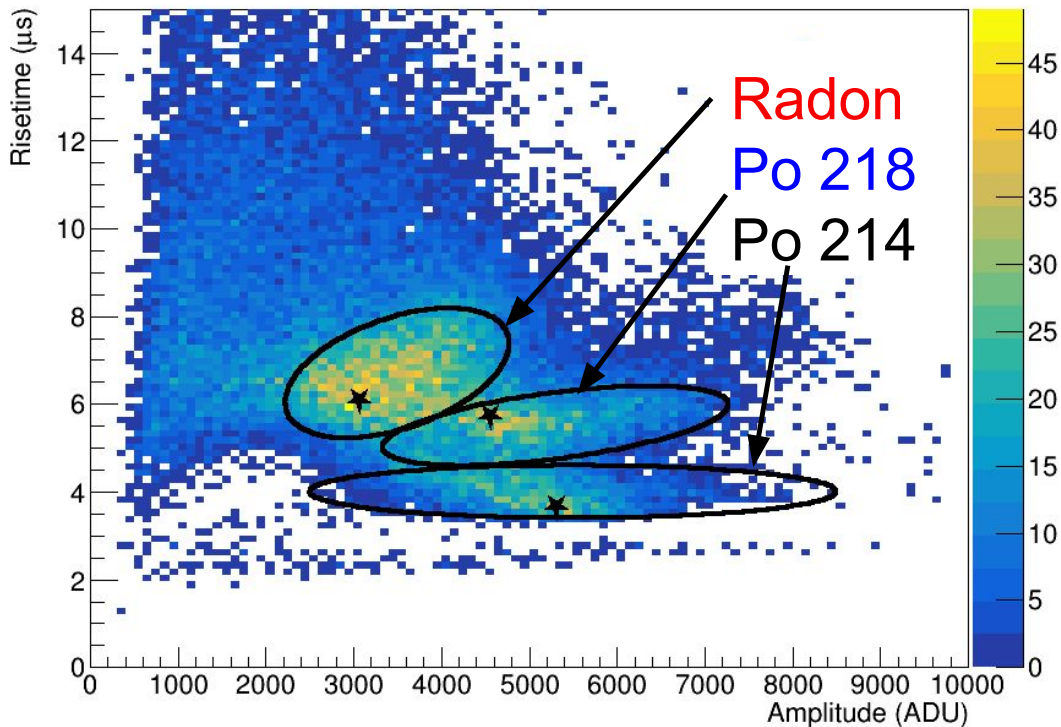

Energy Deposited in Gas by Particle

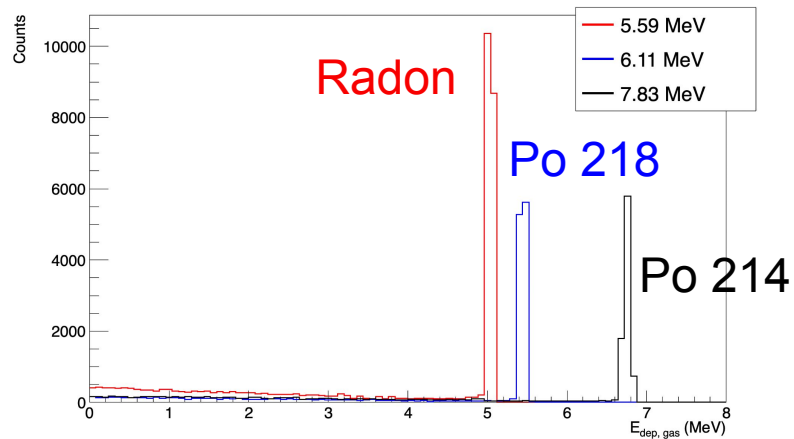

$R_{\max}^3 - R_{\min}^3$  by Energy

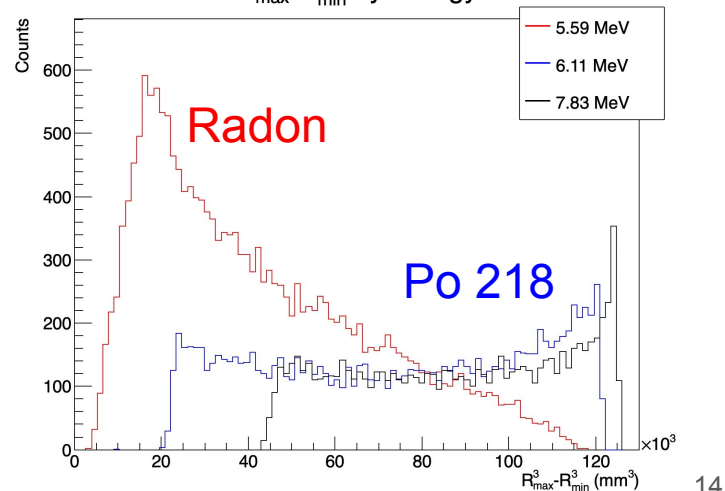

Po 214

# So how much radon is there?

Ellipse 1: Events per hour with 3.82 Day Decay Fit

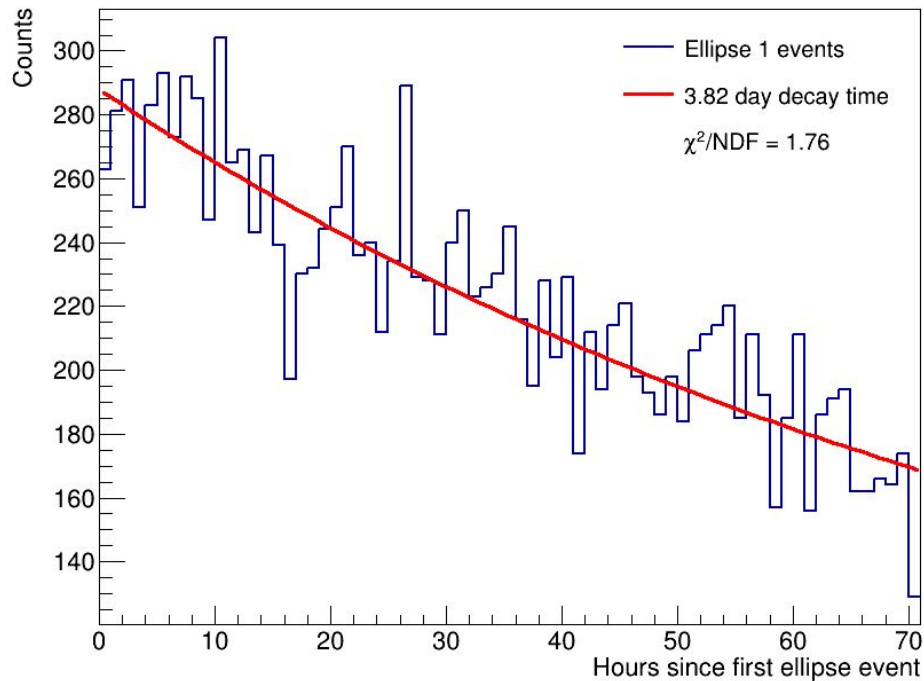

Amplitude vs Risetime Histogram of 17 hour Radon run

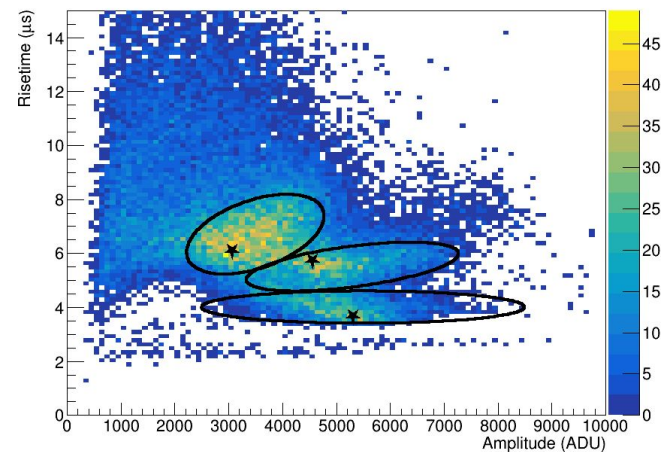

Amplitude vs Risetime Histogram of 79 hour Radon run

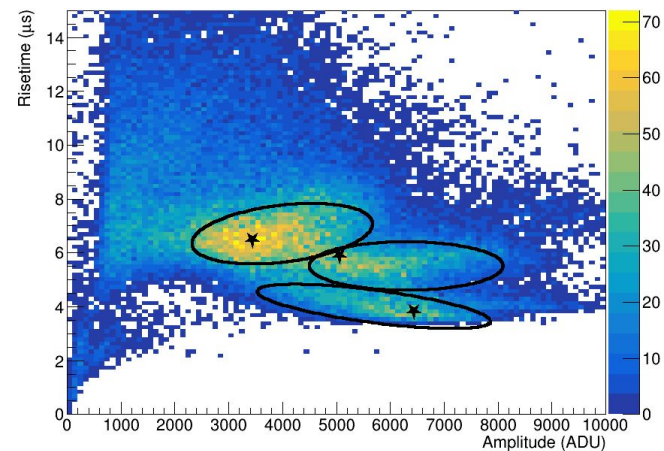

# Final Remarks

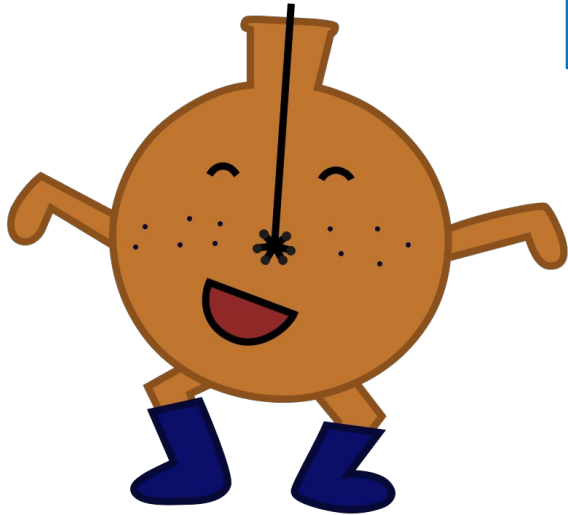



Thanks!  
Questions?

(Image credits: Alyssa Sanden, NEWS-G for mascots)

# Attempting to get Better Data

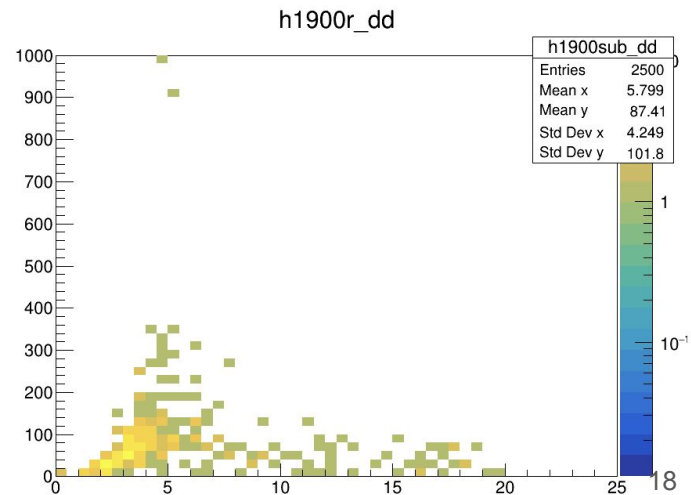
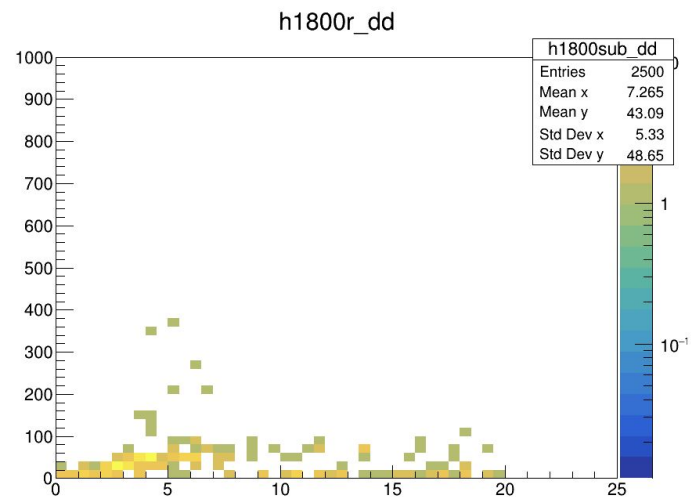
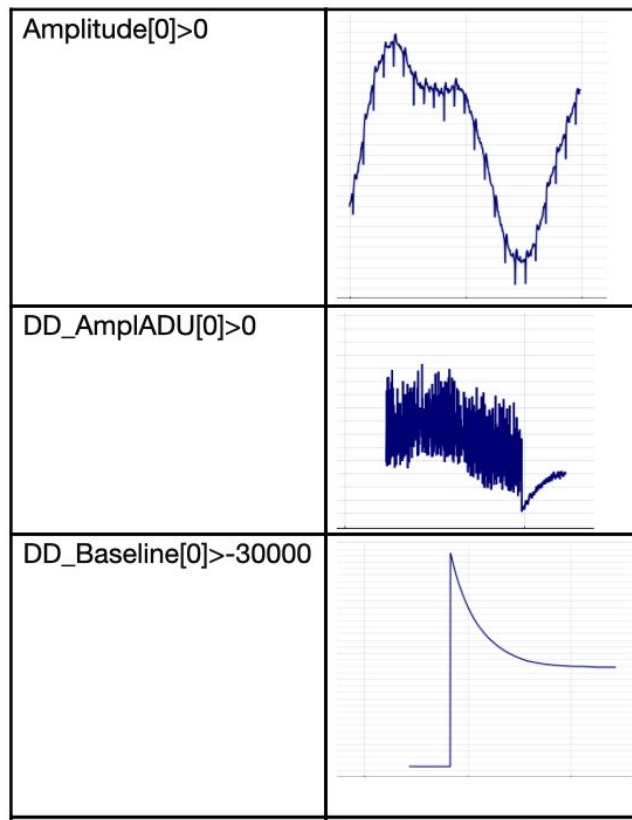
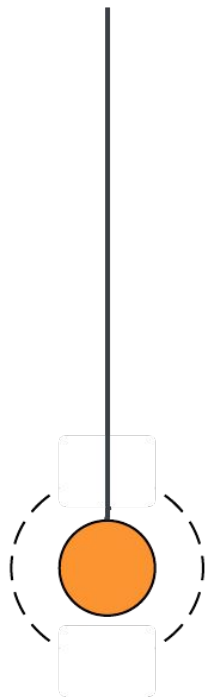

# Heater Development

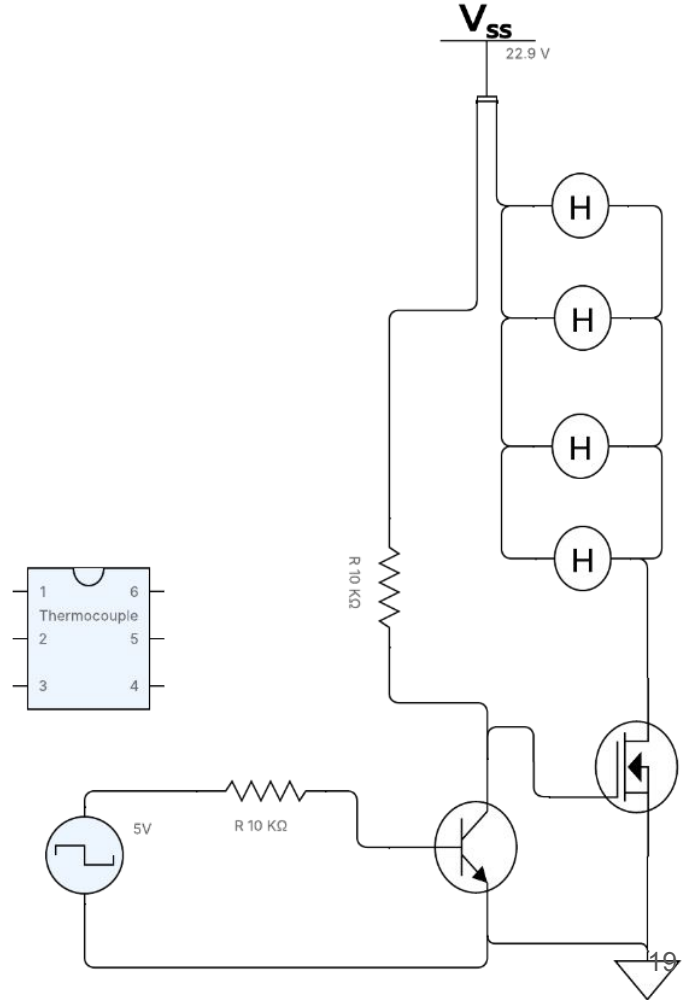
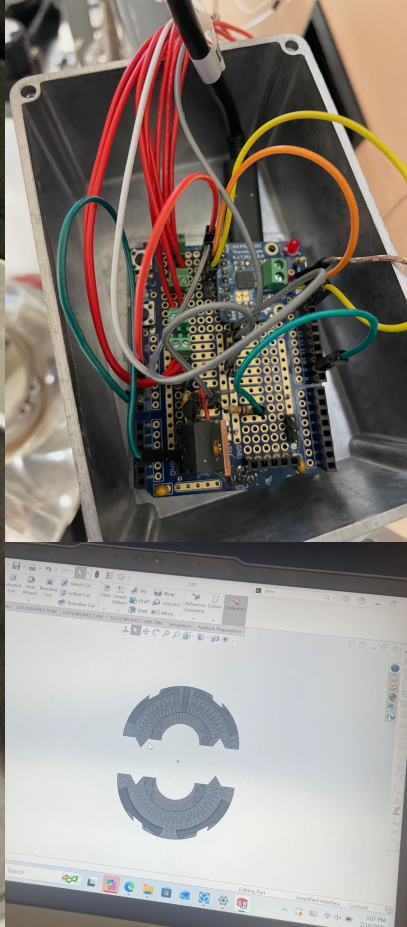
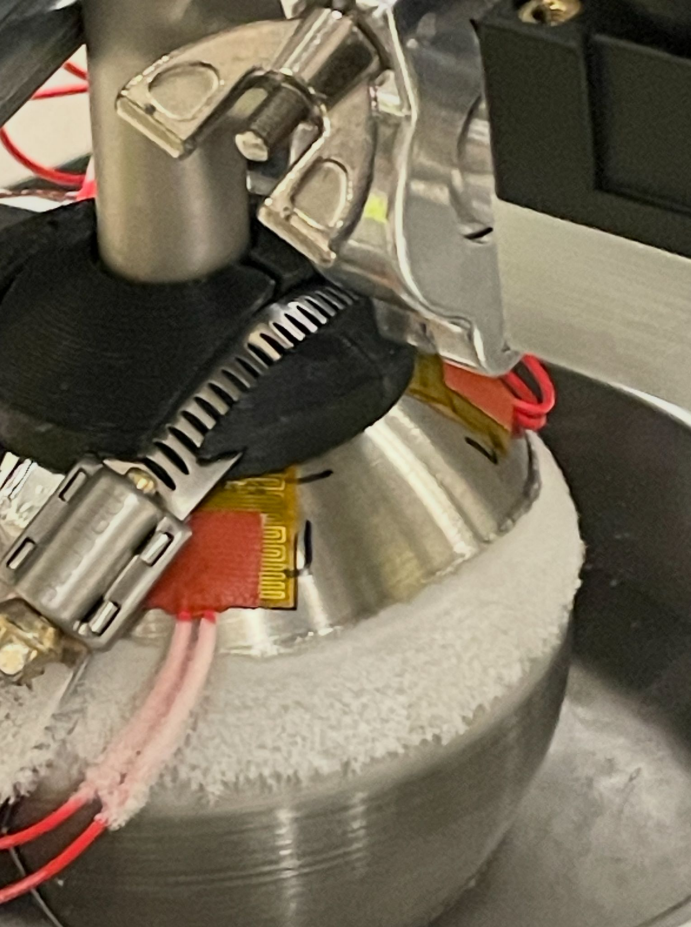

# Why its better than lucas cells / purpose of detecting radon

(better from connor later on)

(Full radon board description)

(number slides)

(Does software or amplifier flip it)

Ions moving away changes voltages

Check % on cylinder (maybe 98, 2)

Fix dates

Flip direction of amplifier plot

Ignore T1 entirely

Take off step

Pick new colors, arrows on 17

Units on everything

Using geant4 for simulation

