

04/17/2026

Engineering and Operations in the SNO+ Scintillator Plant: AV Draining

Cameron Van Der Zyl

SNO+ Cleanliness Monitoring Student → SNO+ Processing Plant Student



SNO+ Detector

Made up of many layers:

- Cavity (Filled with UPW)
- PMT Support Structure (PSUP)
- Acrylic Vessel
- Liquid Scintillator

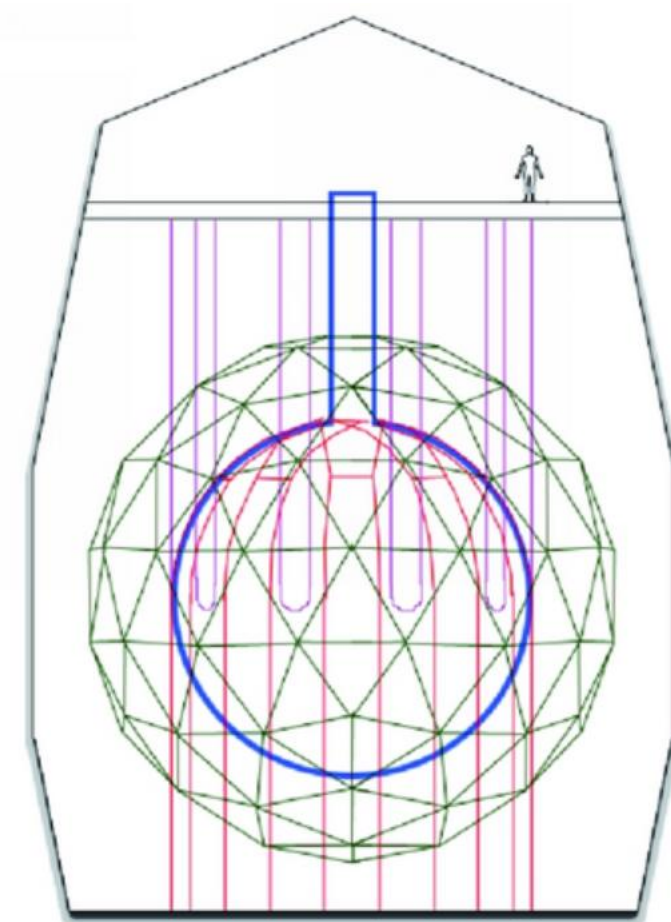
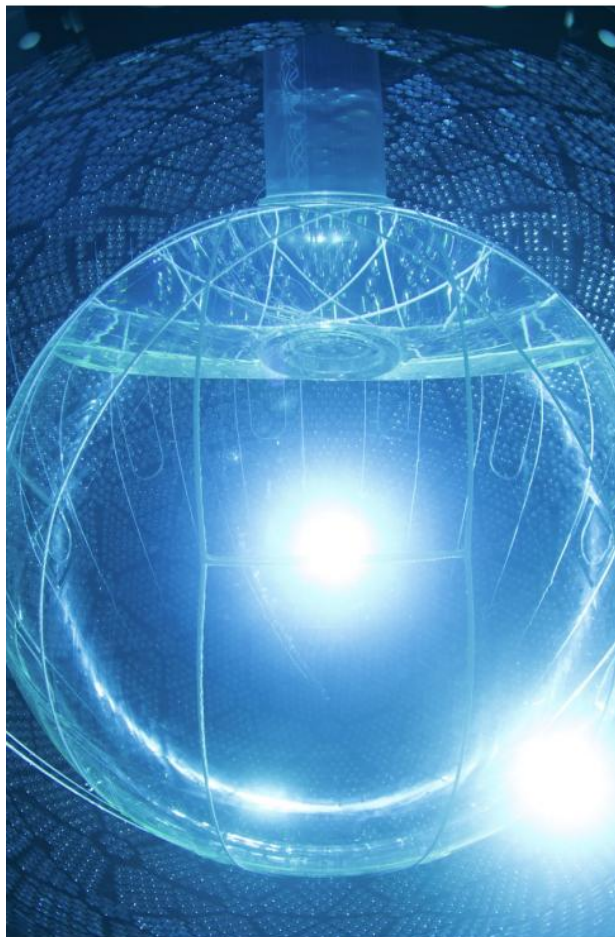

Why is draining happening?

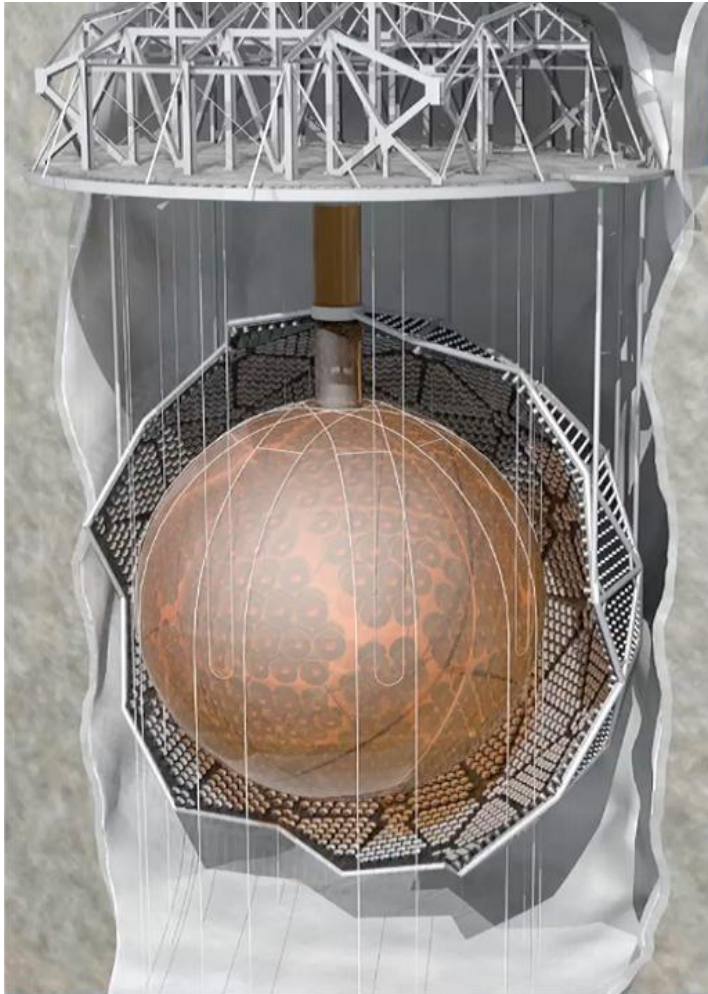

Why is draining happening?

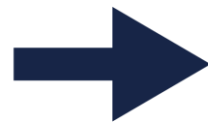
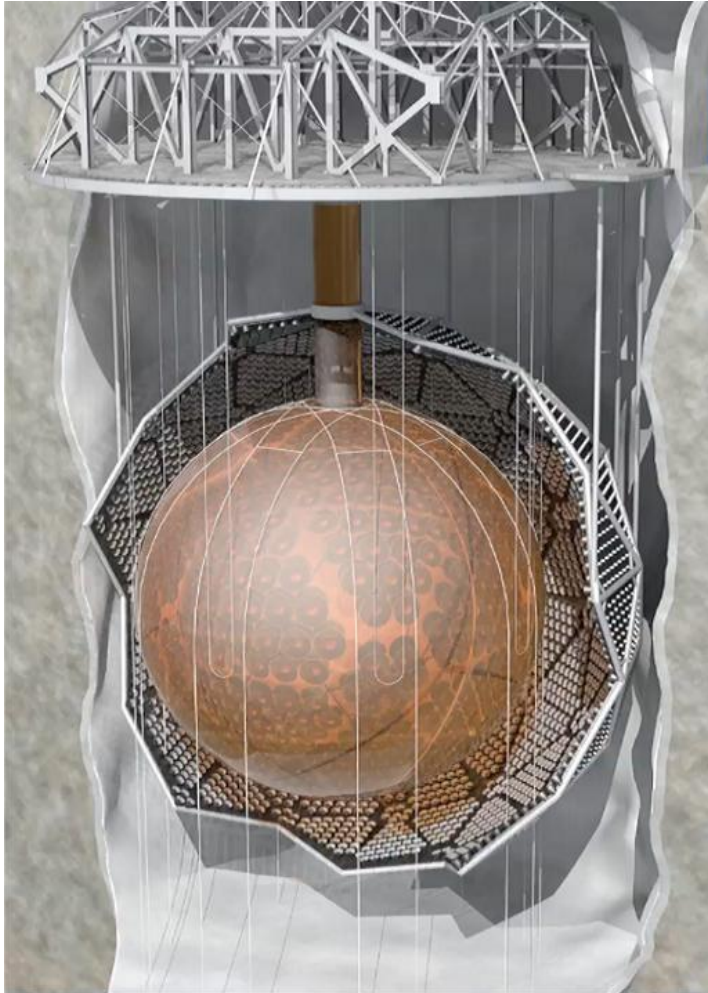

May 23rd, 2025
**Seismic
Event**

Why is draining happening?

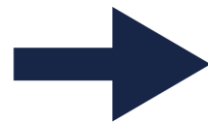
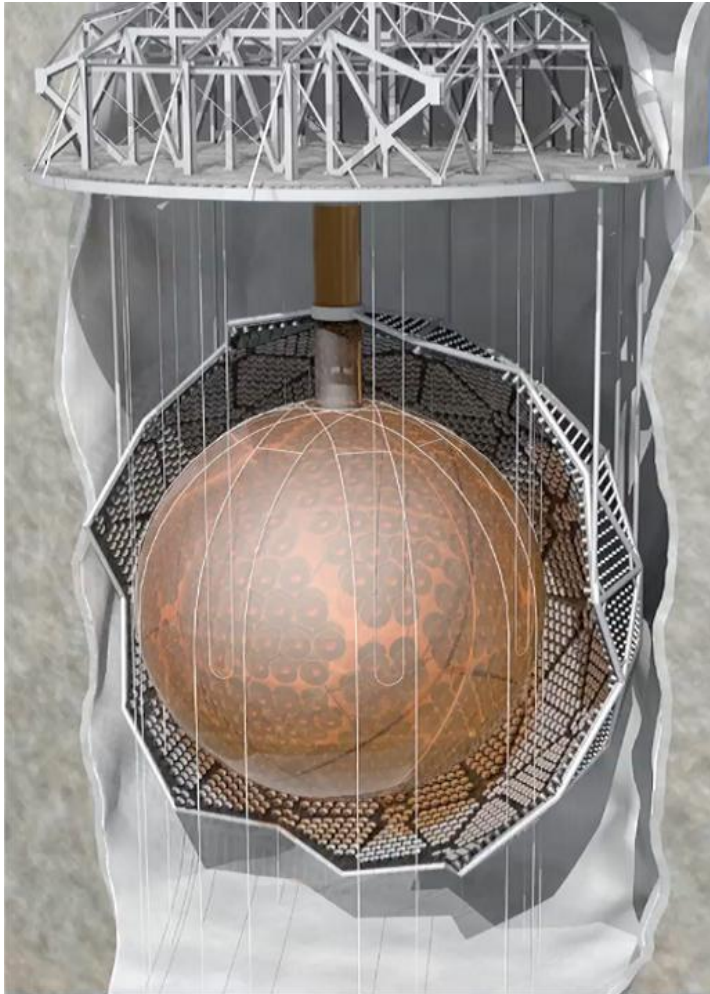

May 23rd, 2025
Seismic
Event

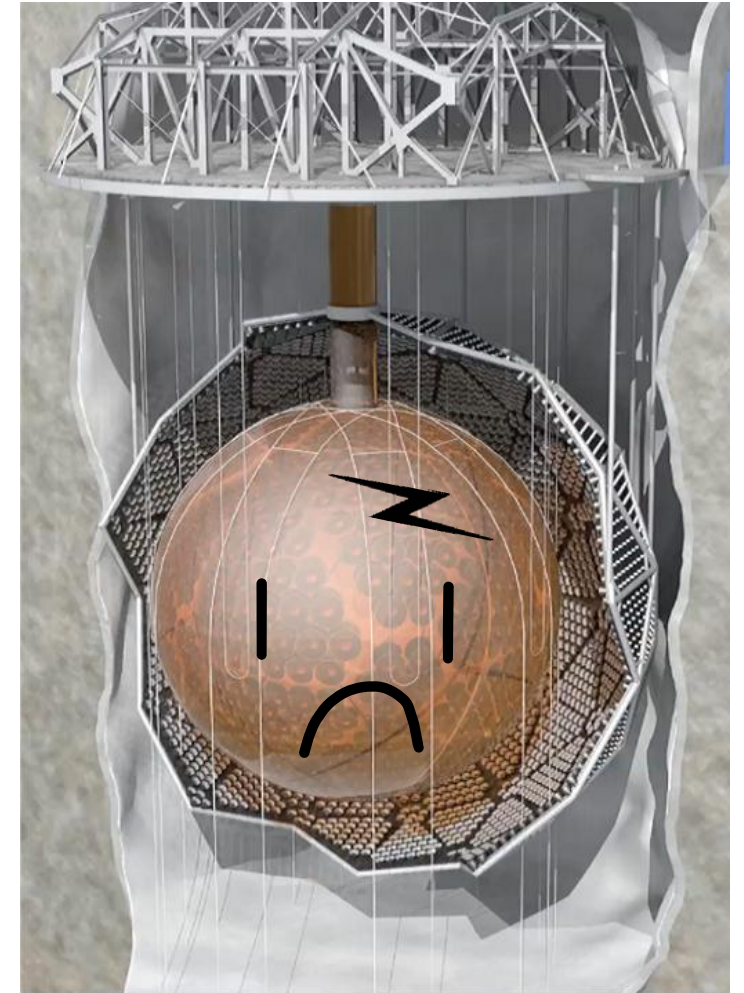
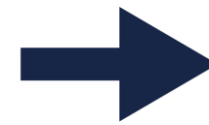

The Problem: AV Leak

- Small amounts of water leaking into AV
- Crack estimated to be $\sim 1\text{mm}^2$
- Using differential pressures; Crack located $\sim 480\text{cm}$ above equator
- To repair, draining of the AV and Cavity is required
- Acrylic is not easy to patch

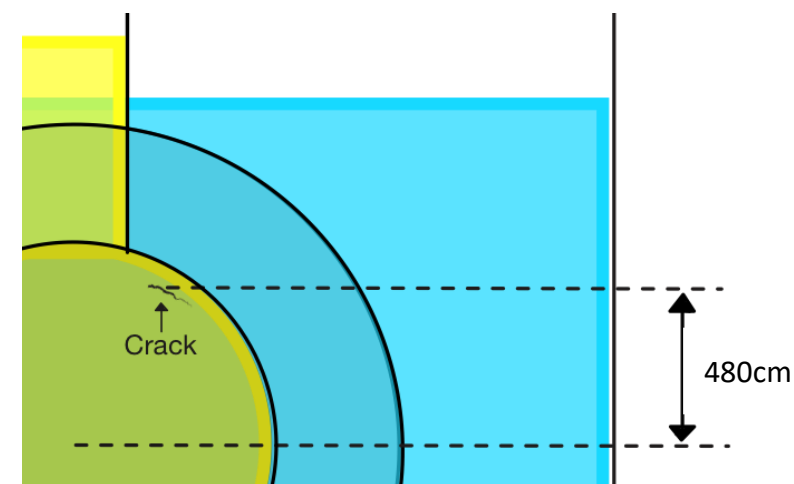
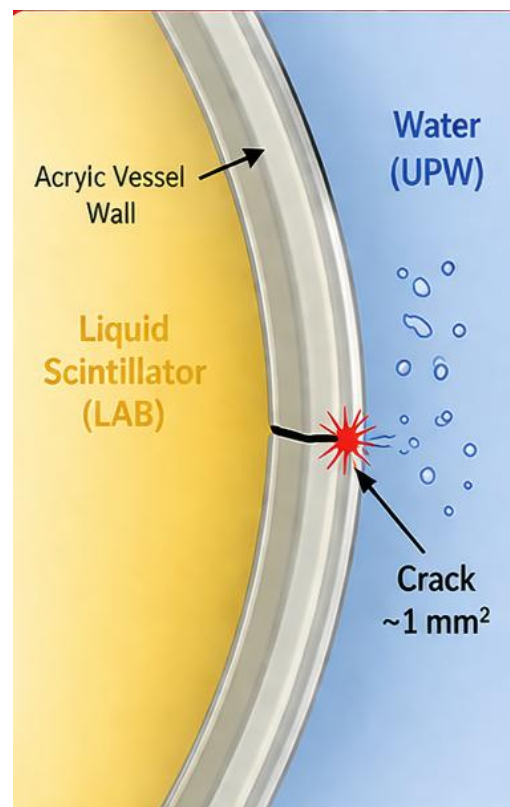

Critical Constraint: Differential Pressure (dP)

- Detector is made up of two fluid layers
- Required dP: 0dP at neck $\pm 5 \text{ inH}_2\text{O}$
- Current Operational dP: $-10 \text{ inH}_2\text{O}$ to $-1.5 \text{ inH}_2\text{O}$
- Must keep:
 - AV safe (avoid stress on crack and neck)
 - LAB out of cavity
- Scintillator Density @ 12°C $\sim 869.0 \text{ kg/m}^3$
- UPW Density @ 12°C $\sim 999.45 \text{ kg/m}^3$
- The cavity level is $\sim 3\text{ft}$ lower than the AV when full giving a dP = 0
- As level is lowered in cavity and AV, smaller changes in level make bigger changes to dP

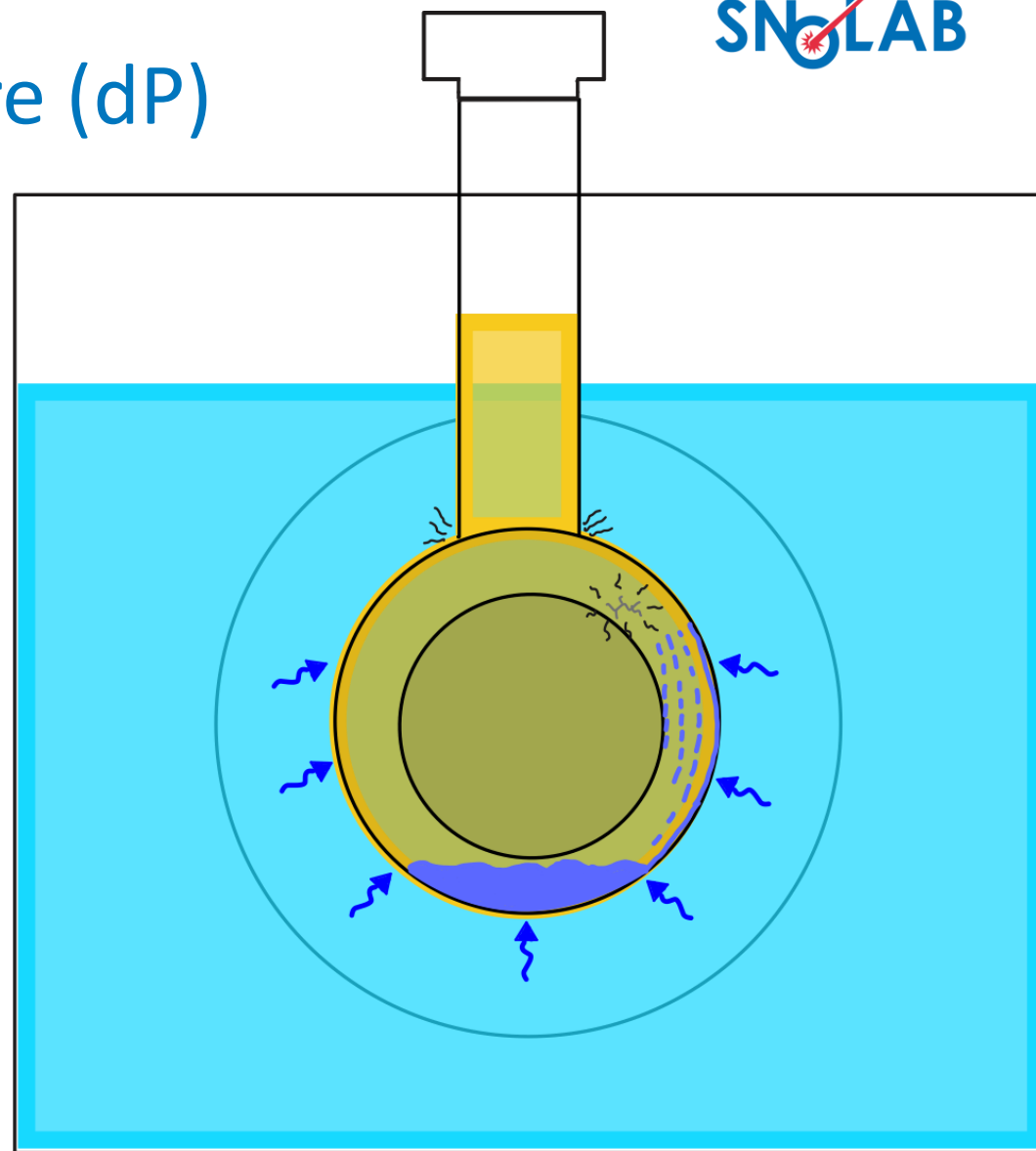

Draining Progression

Initial, Current, and Future draining methods

Initially

- Drain from the AV to 60 tonne tanks
- Flow path is direct
- Large distance to travel
- Very simple, no processes

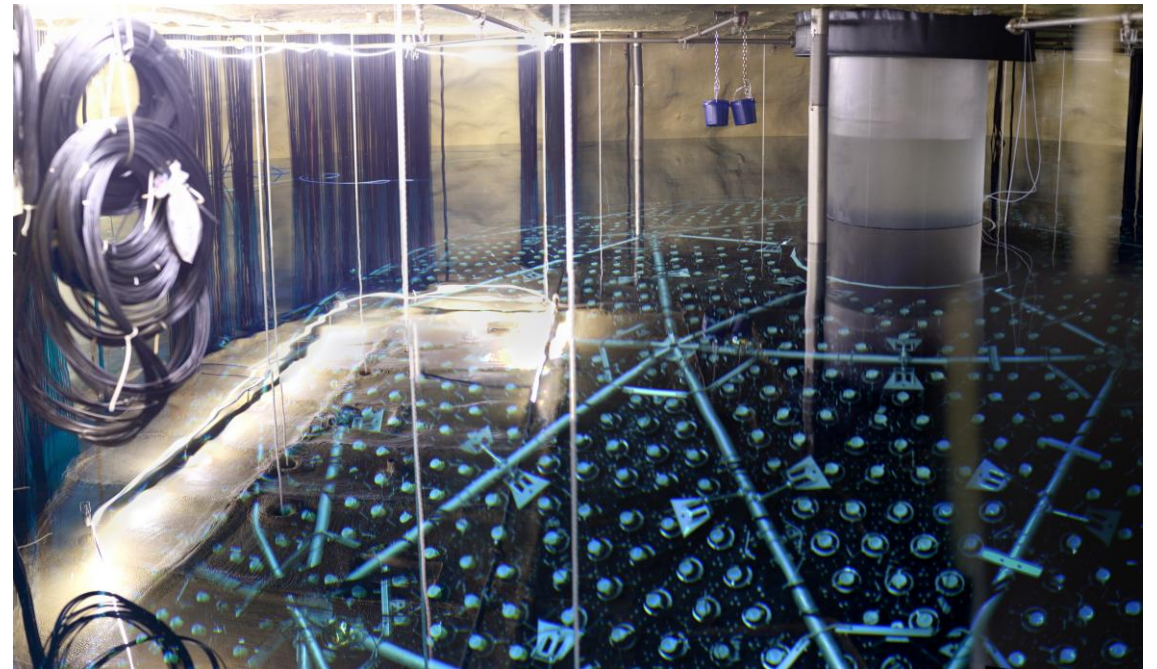
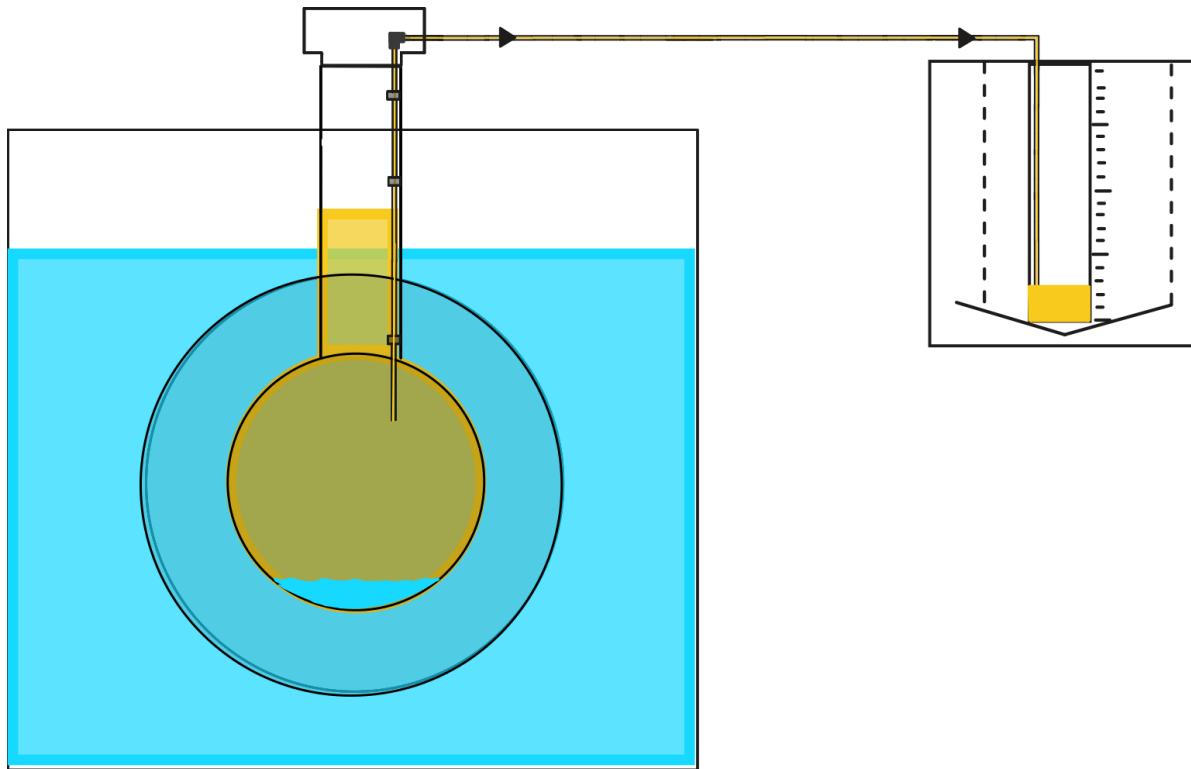

Initially

- Use a bubbler pump & line to pull from bottom
- Pump to a tote in SNO+ control room
- Monitor potential scintillator uptake

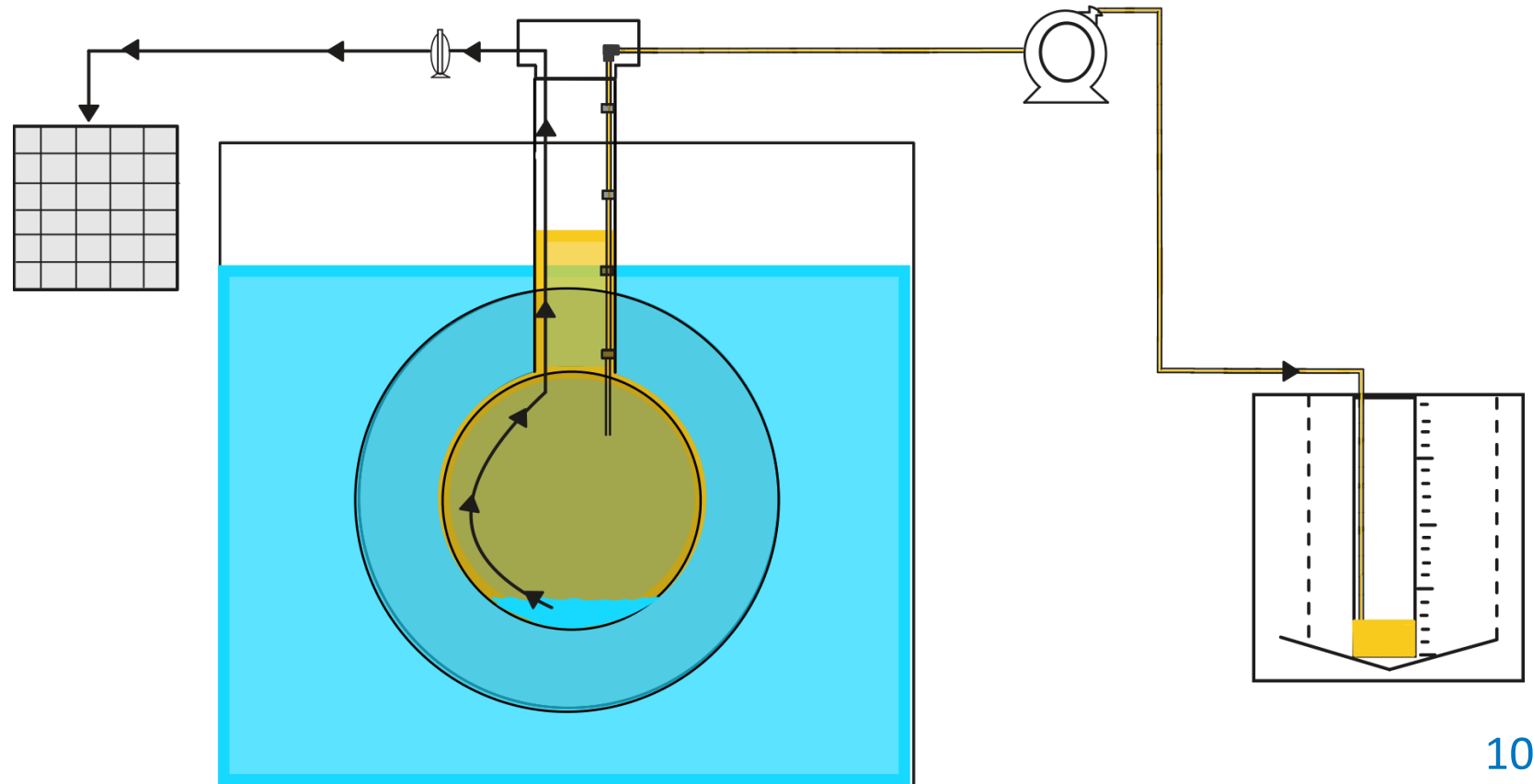

Initial

- Centrifugal pump in line
- Cannot pull suction → requires flooded inlet
- Limited ability to draw from deep AV

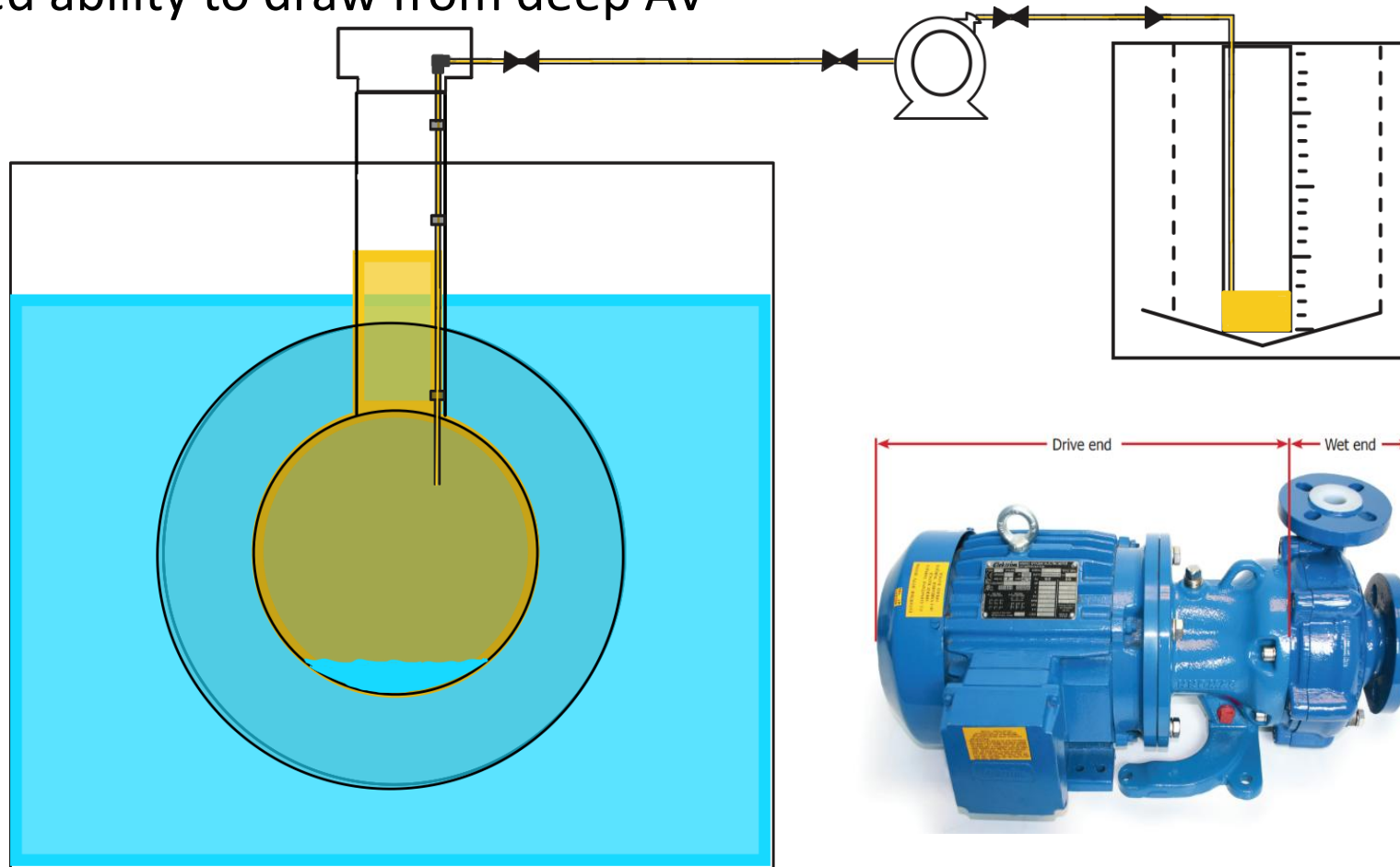

Initially

- Addition of a Diaphragm Pump
- Can pull suction (28ft head) → required for deeper draining

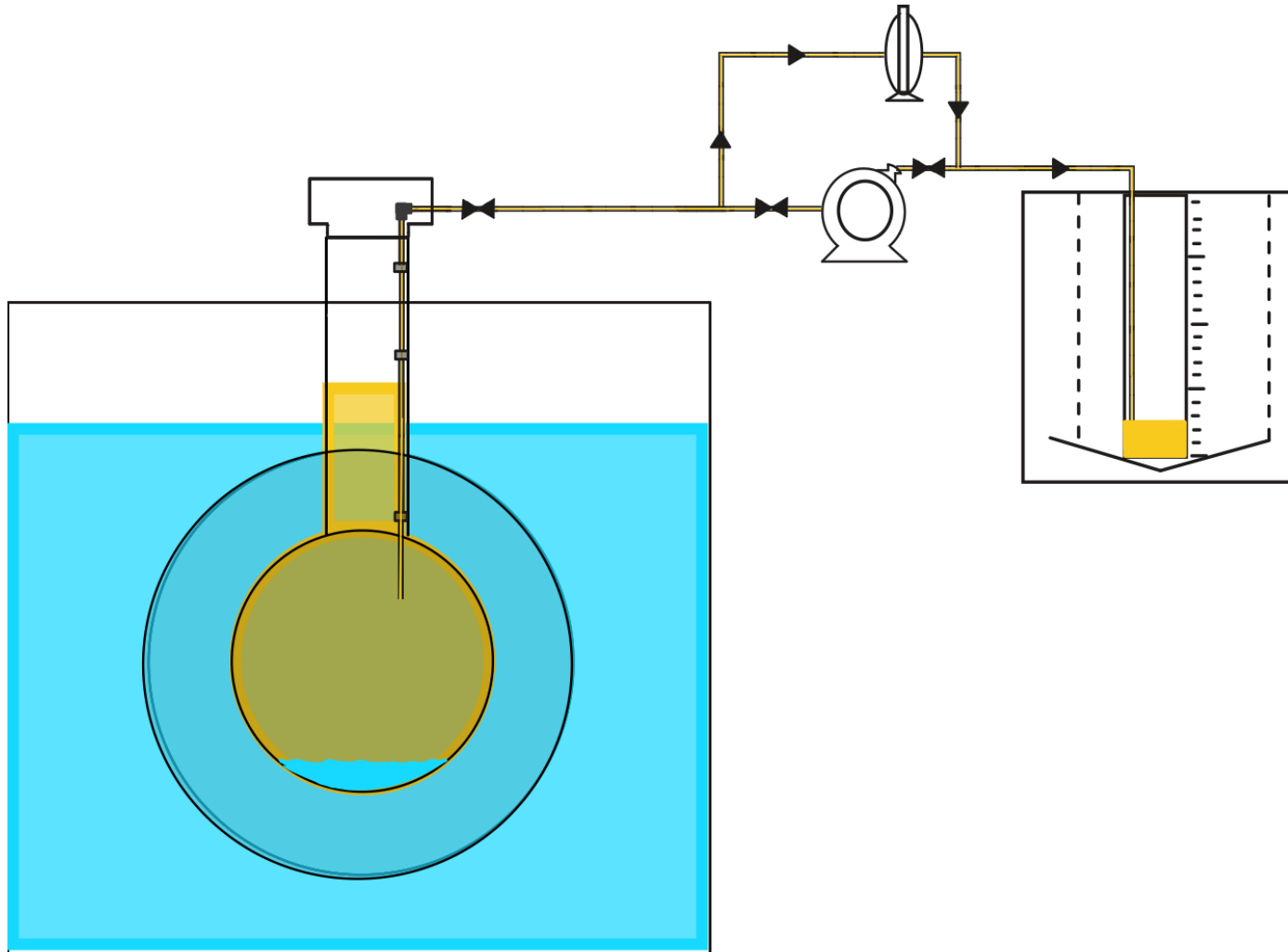

Centrifugal vs. Diaphragm pumps



vs.

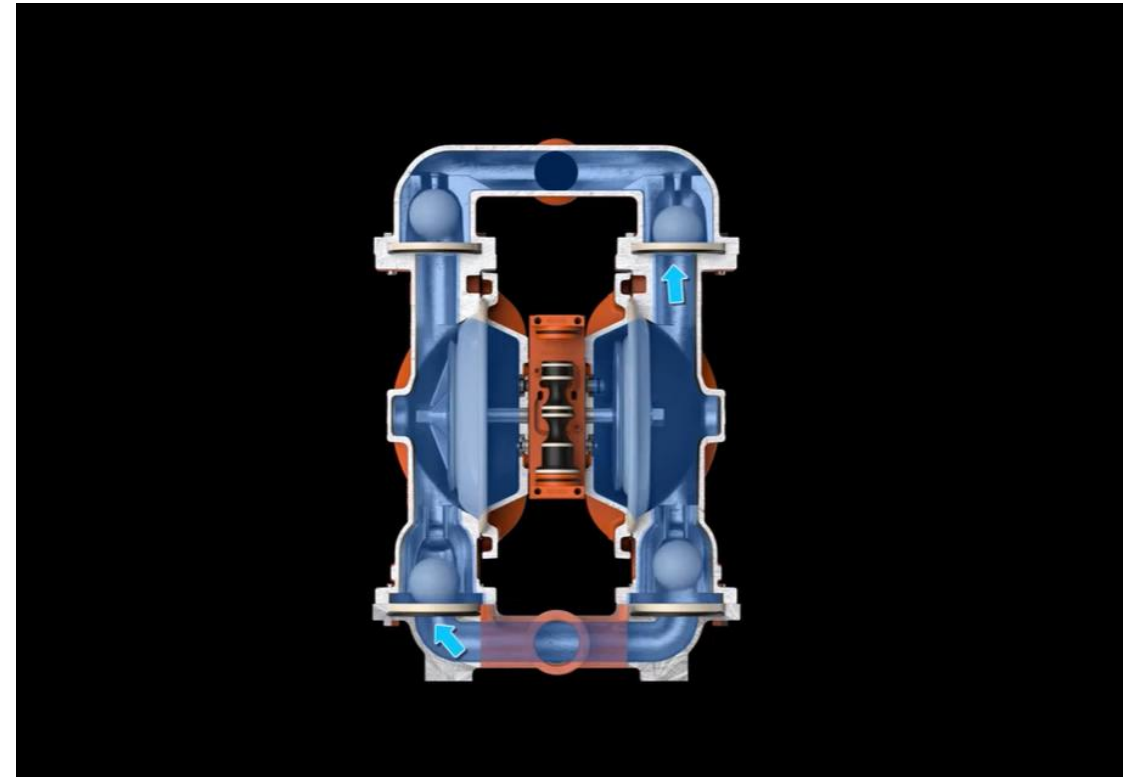

Current

- Use a stripping column to assist pump
- Draws vacuum on line for more net positive suction lift

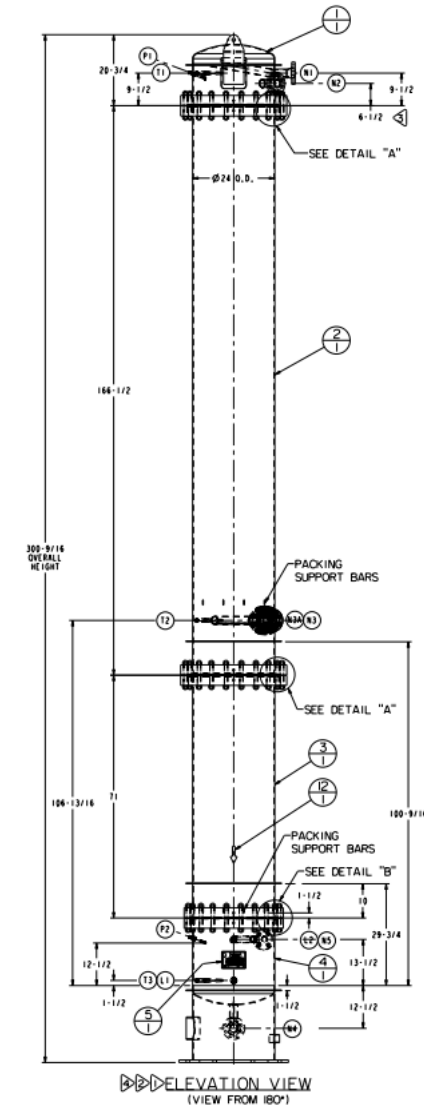
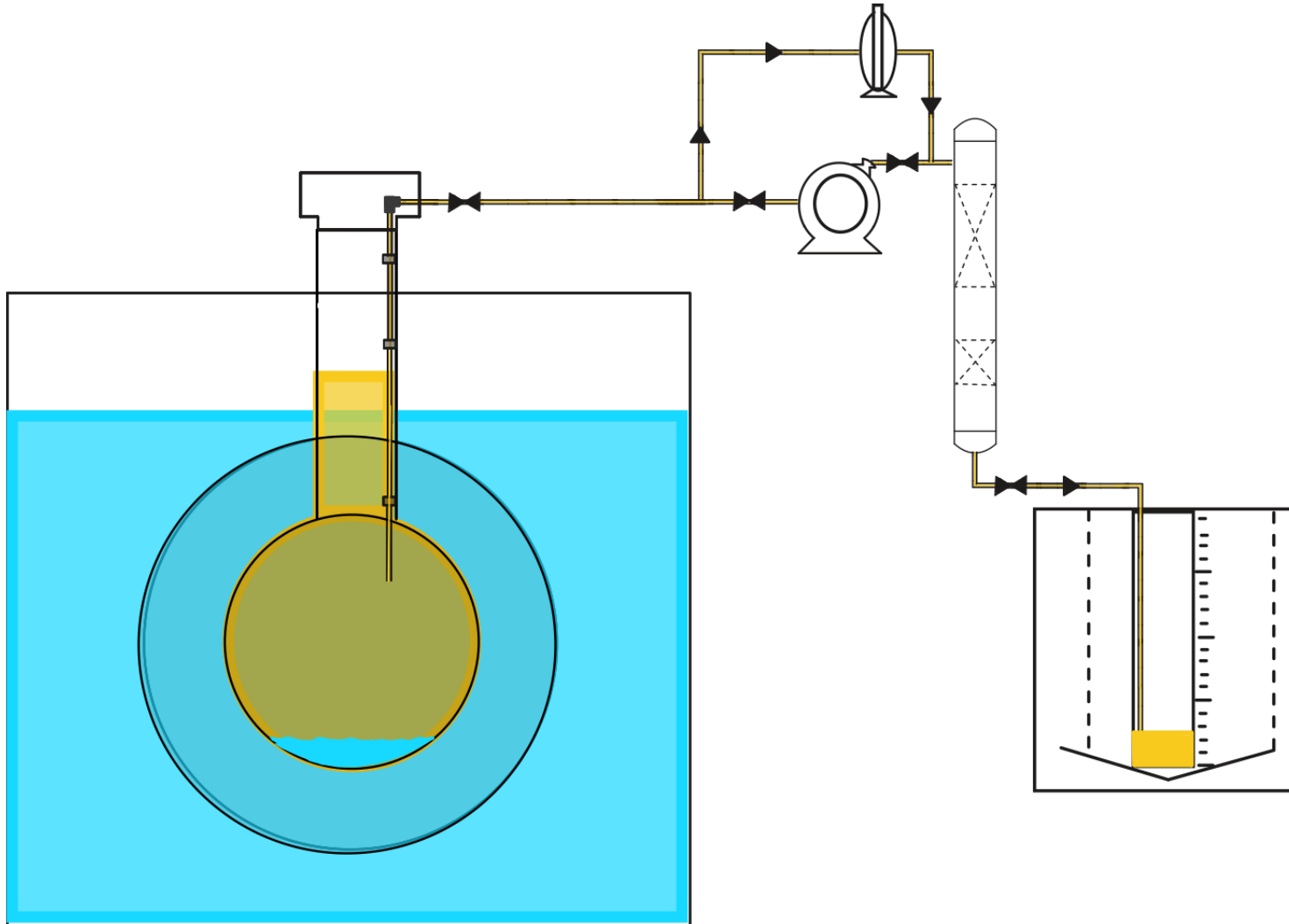

Current

- Using an Acrylic Pipe
- Made up of many small sections with connection points
- Sealed using O-rings → incorrect sizing leads to leaks at joints
- Generally unreliable

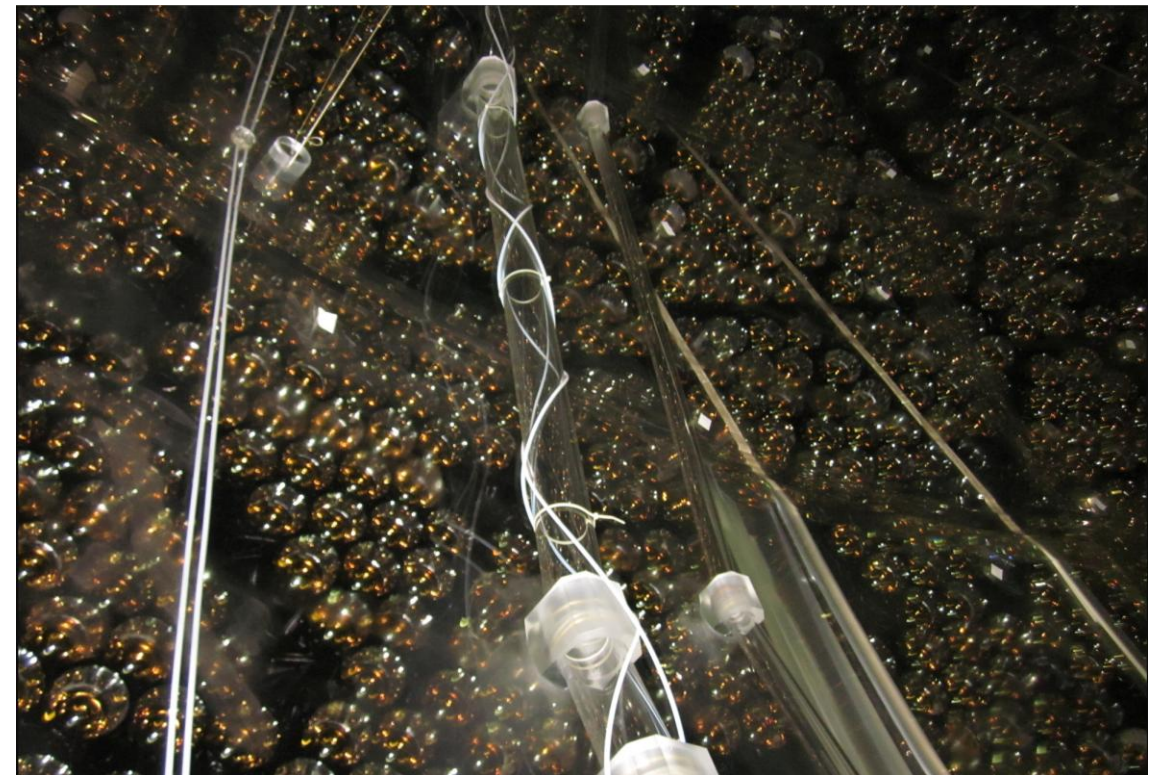
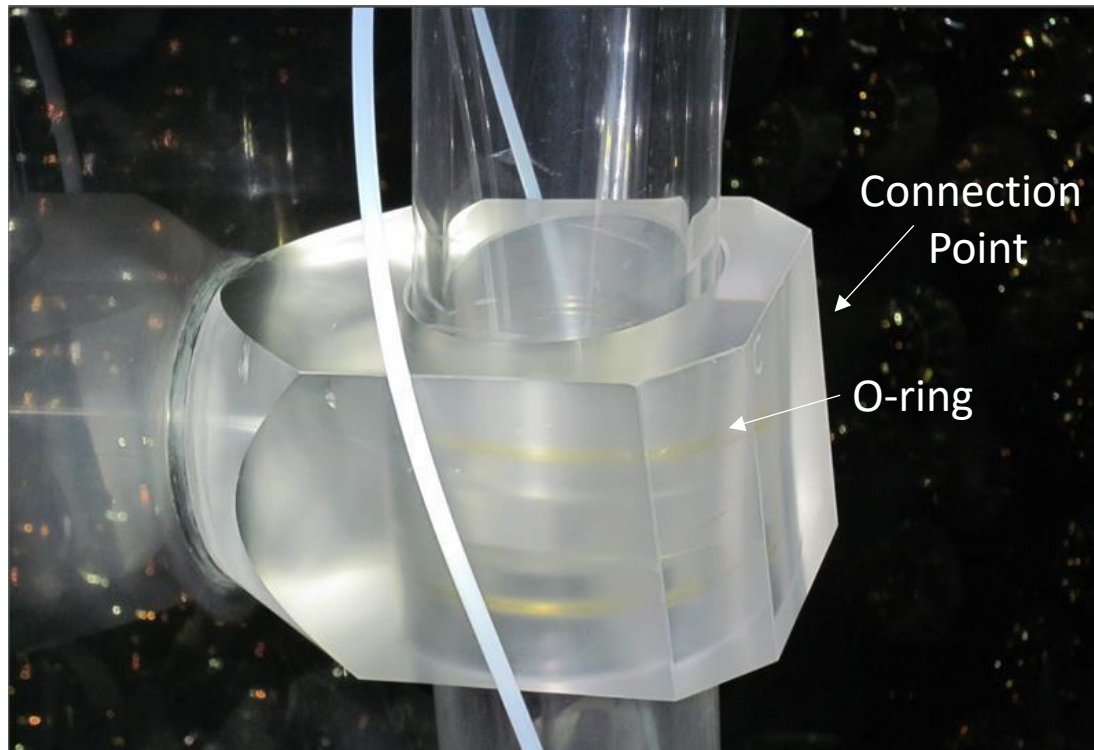

Gas Ingress Problem (N_2)

- When AV level drops below leak \rightarrow gas enters system
- Pump draws N_2 instead of liquid
- Causes
 - Loss of pump prime
 - Reduced flow
 - Plant instability

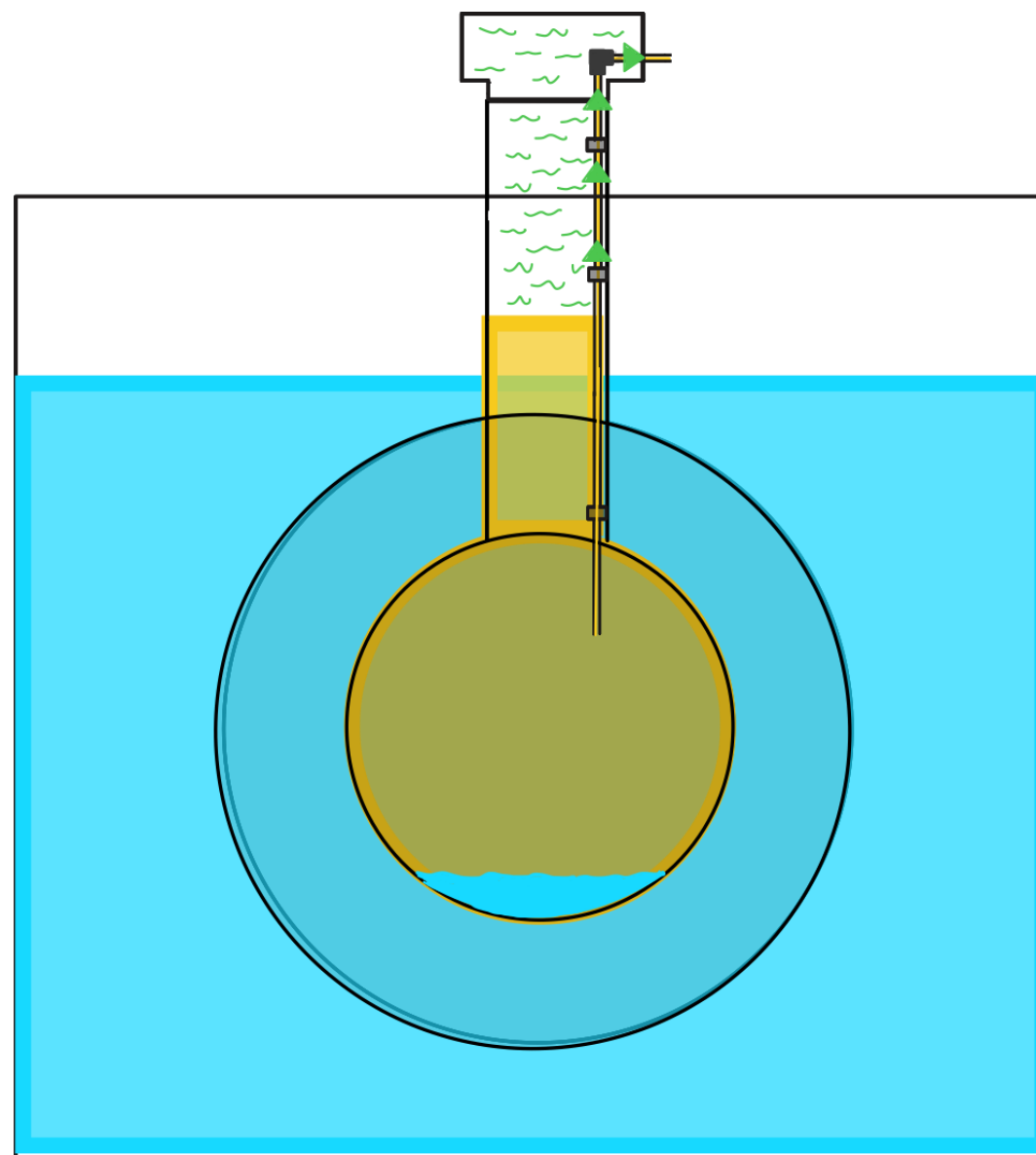

Current

- Switched to bottom line to avoid gas intake
- Causes intake of water
- May be pulling through connection points

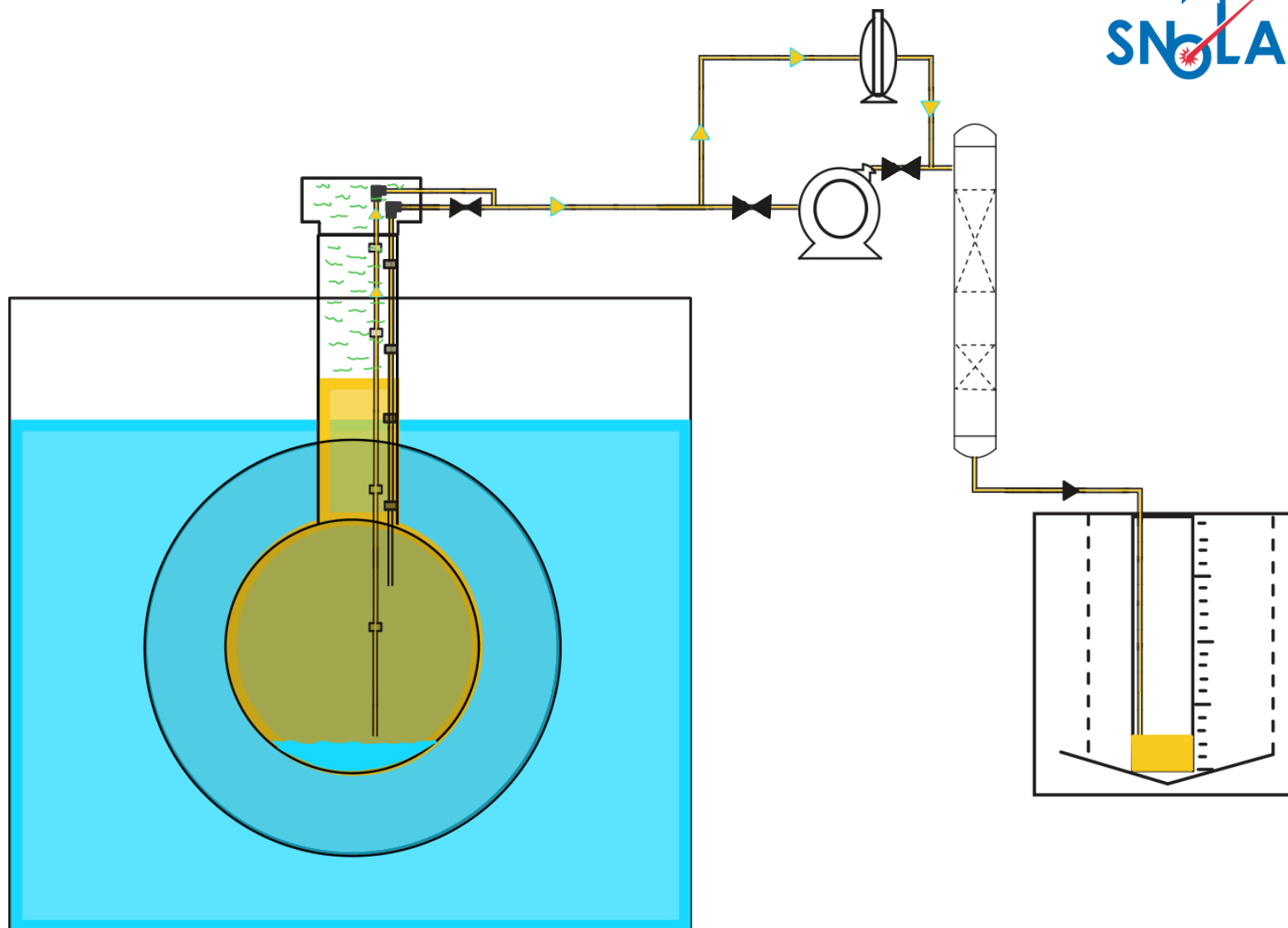

Current

- Start using stripping column with heat
- Running batch stripping
- Unknown amount of water with scintillator

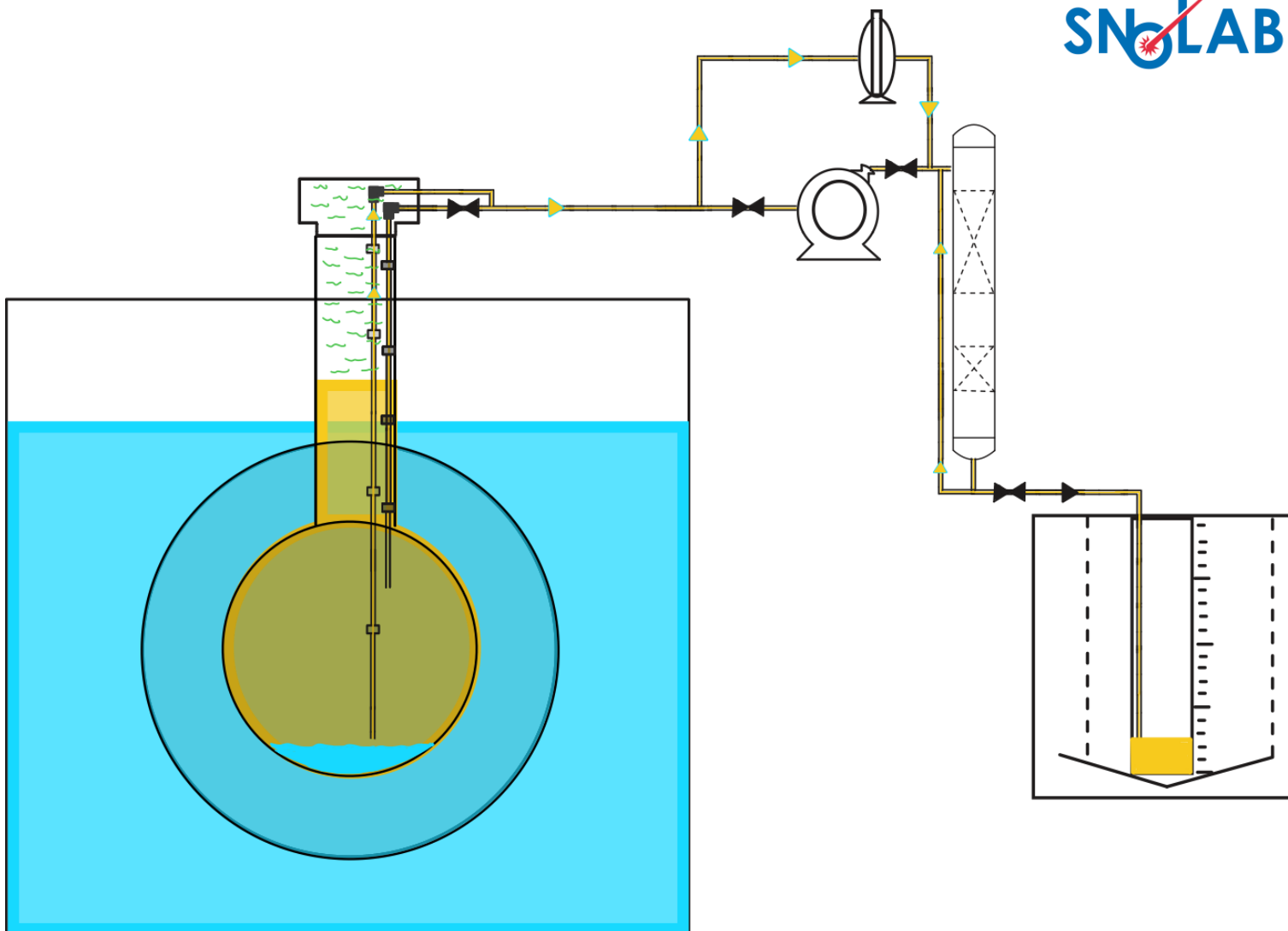

UPW Plant



- Continuous draining
- During normal operations, flow is split between recirculation and cooling

- During draining, recirculation flow is altered
- Flow can go straight to drain

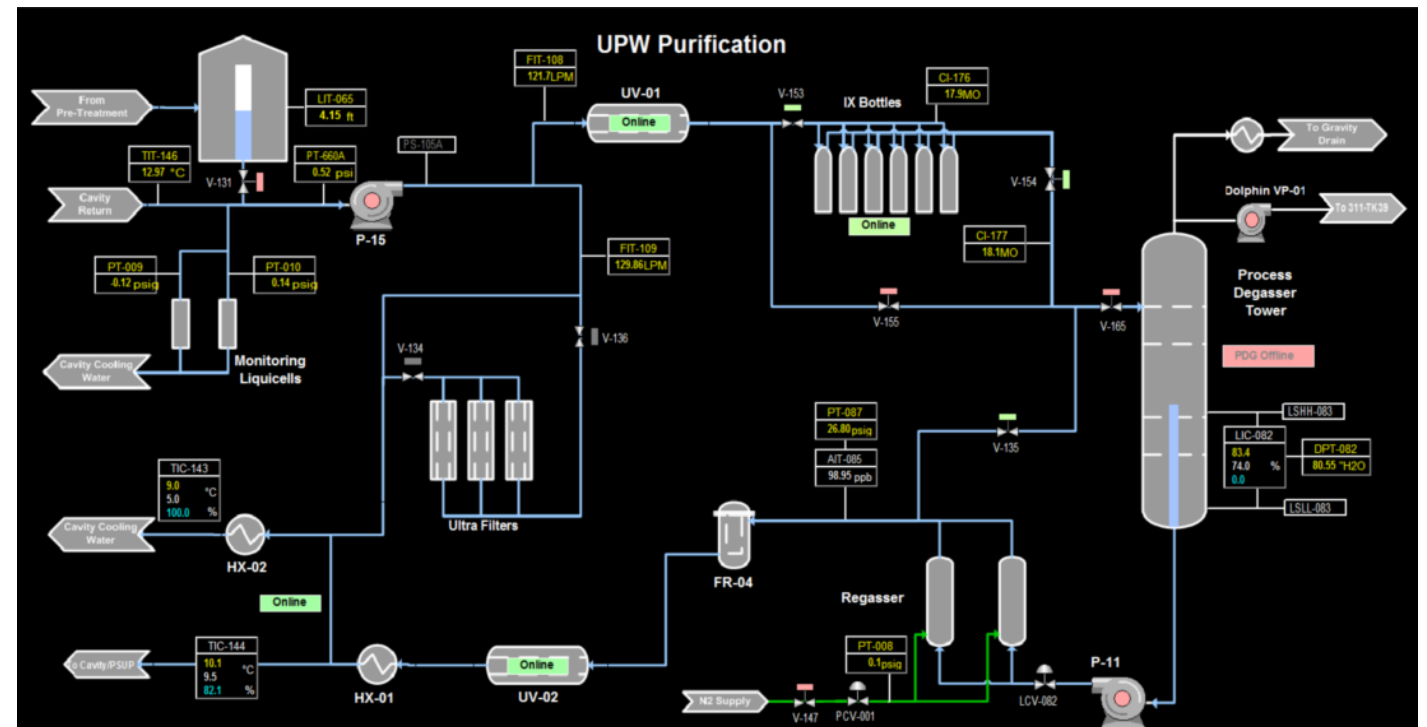
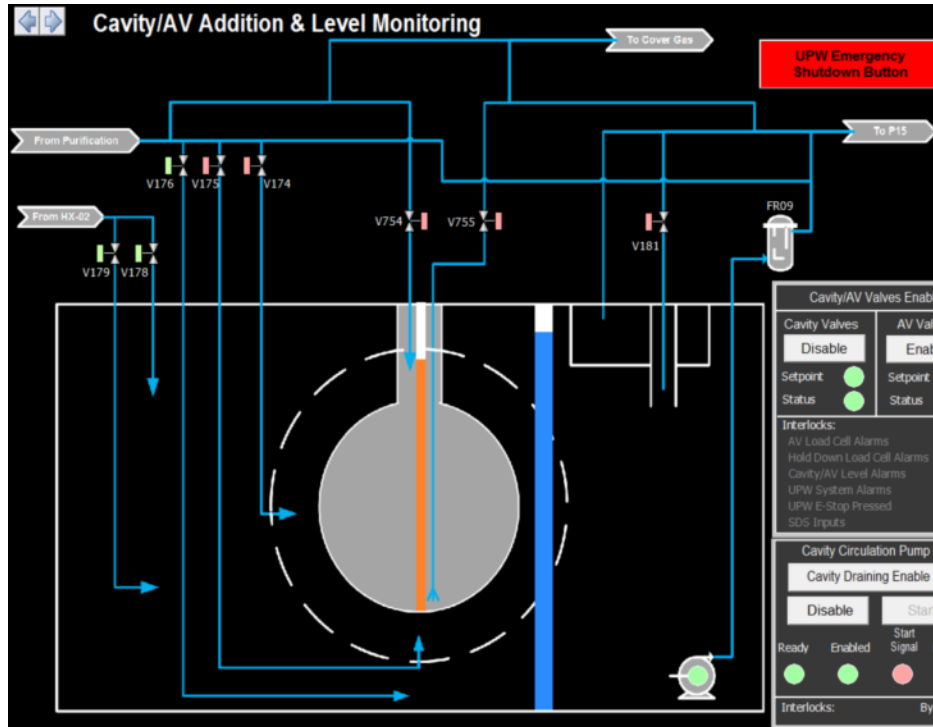

Plant Interactions

- UPW drains continuously
- Scintillator plant adjusts to match
- dP must stay within $\pm \sim 1.5 \text{ inH}_2\text{O}$

Faceplate3

OPERATING-DPTRIP ✕

Operating LOLO and HIHI

ENABLE

Status: **DISABLED**

Setpoint (in):

Bound (±):

New LOLO: -9.00

New HIHI: -6.00

LOLO cannot go below -10
HIHI cannot go above -1.5

Cavity Valves: AV Valves:

Setpoint: ● Status: ● Setpoint: ● Status: ●

Interlocks:

AV Load Cell Alarms

Hold Down Load Cell Alarms

Cavity/AV Level Alarms

UPW System Alarms

UPW E-Stop Pressed

SDS Inputs

Cavity Circulation Pump P16

Cavity Draining Enable

Ready: ● Enabled: ● Start Signal: ● Running: ●

Interlocks: Bypass:

DVSYS.OPERATING-DPTRIP/ENABLED.F_CV

Cavity/AV Auto Fill

V-755 ● V-175 ●

Operating DP Trip: **Disabled**

Permissives:
Cavity/AV dP < 2' and > -2'

Interlocks:
Cavity/AV Valves Disabled

Enabled: ● Status: ●

Cavity AV Level Information

Cavity Neck Level: 144.89 inH2O

AV neck level: 177.31 inLAB

Cavity-AV dP: **-7.15 inches**

Interlock Status: **ACTIVE**

AV N2 bubbler timed bypass: TIMER RESET 900

Load Data

AV Up Rope Total Load: 12641 lbs

AV Down Rope Total Load: 236710 lbs

PSUP Total Load: 26601 lbs

Parameter Reference	Descriptor	Value	Units	Timestamp
321-DPT002/SCLR1/OUT.CV	Cavity/AV ...	78.003	inH...	4/8/2026 9:26:53
311-PT087/SCLR1/OUT.CV	Cavity Bu...	71.0	ft	4/8/2026 9:26:53

Future

- Increasing suction requirement as level decreases
- Pump is lowered with level

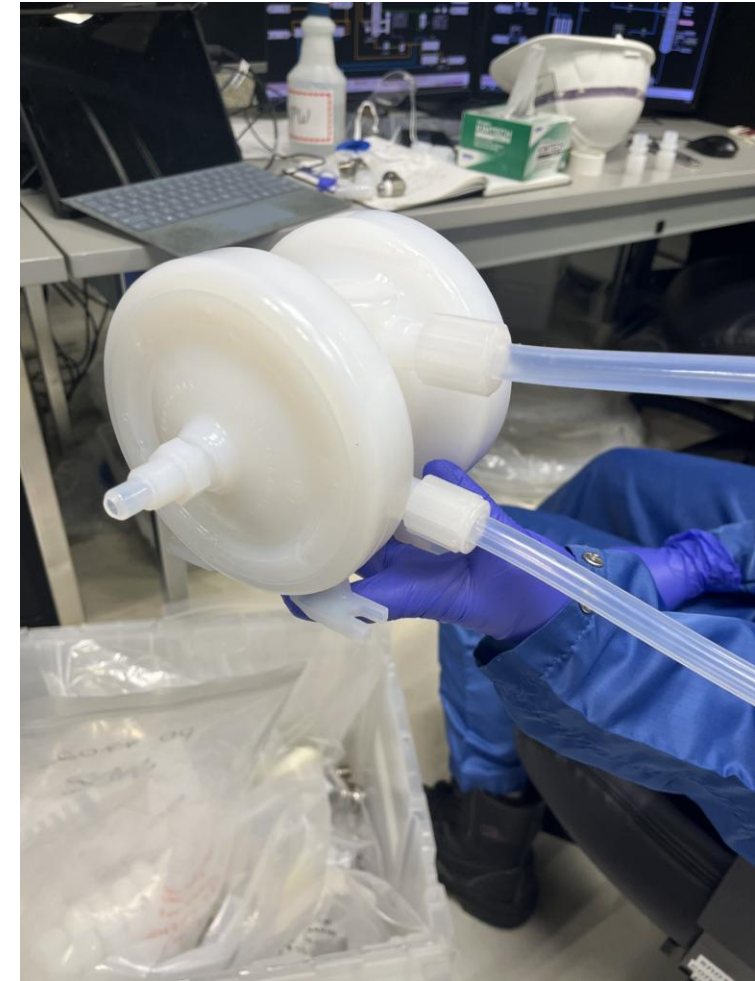
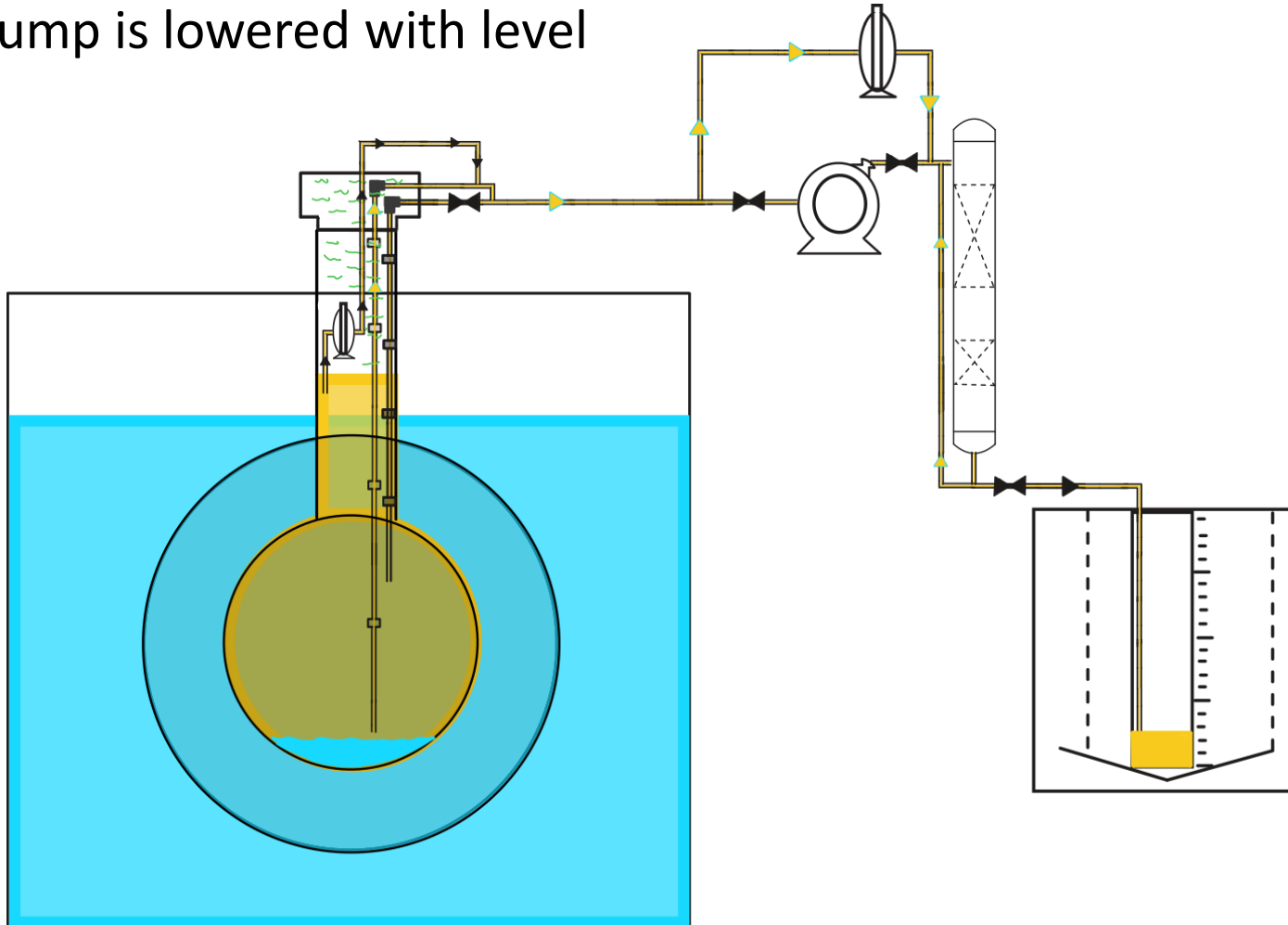

Future

- Draining continues until repaired (hopefully)

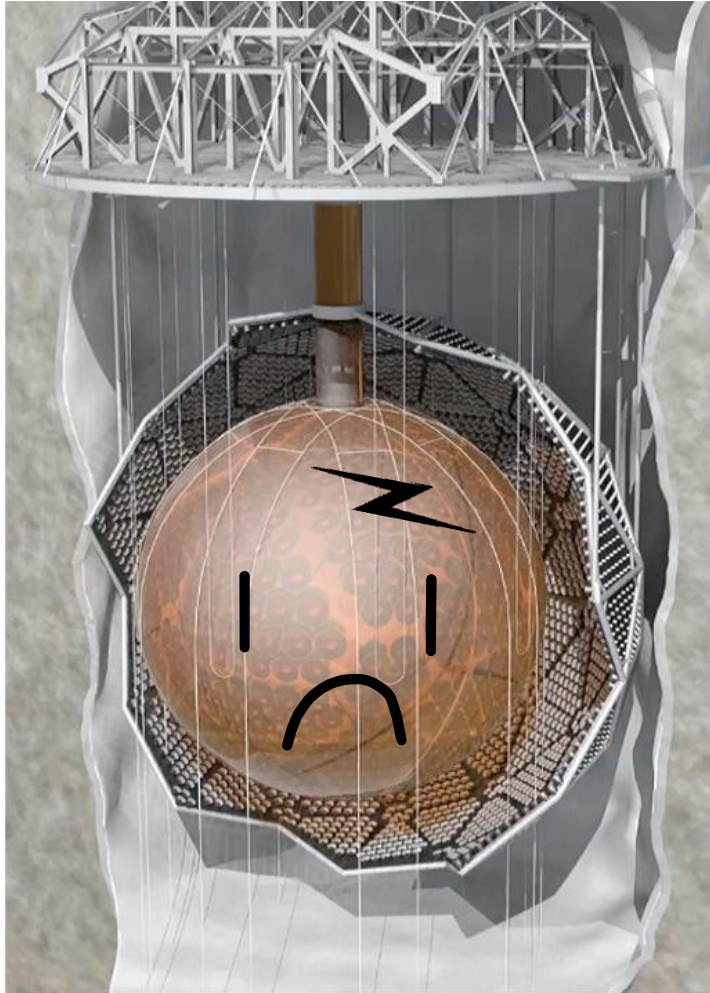

➔ Near Future
Fix Crack ➔

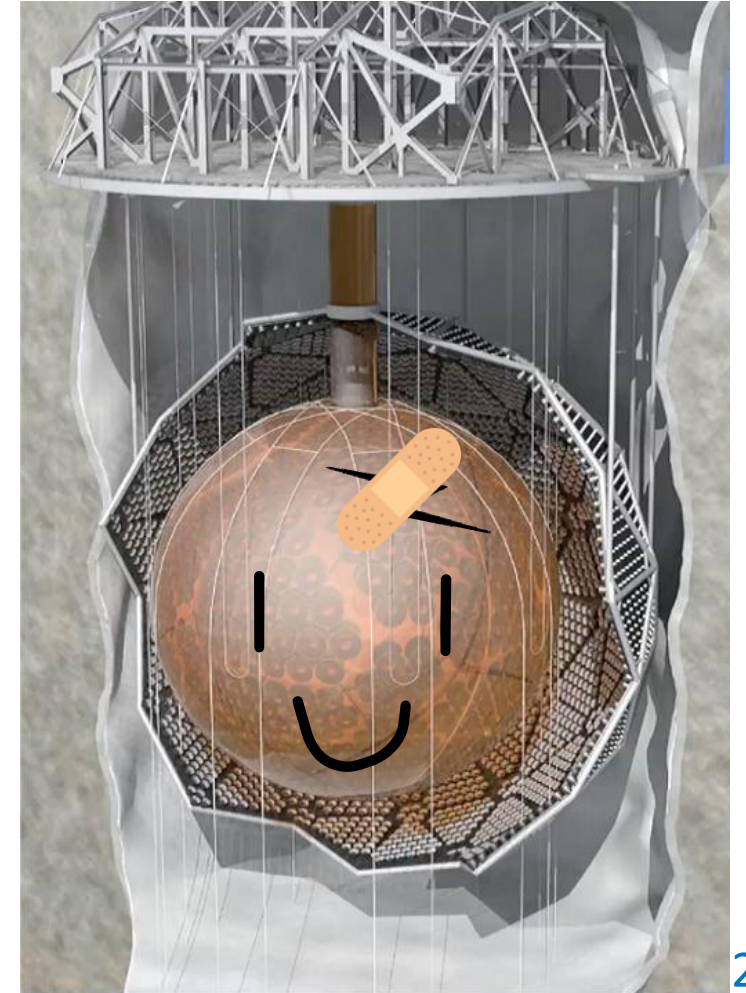

Questions?