

17/04/2026

# RAMPS: Commissioning & Science Run 1

By: Christopher Skora

Supervisor: Dr. Matthew Stukel



# What is RAMPS?

## RadioActive isotope Measurement Program at SNOLAB

Performing novel, precision or standardization measurements of long lived (highly forbidden) isotopes using or enhancing existing equipment at SNOLAB

- Geochronology
- Astrophysics
- Nuclear physics

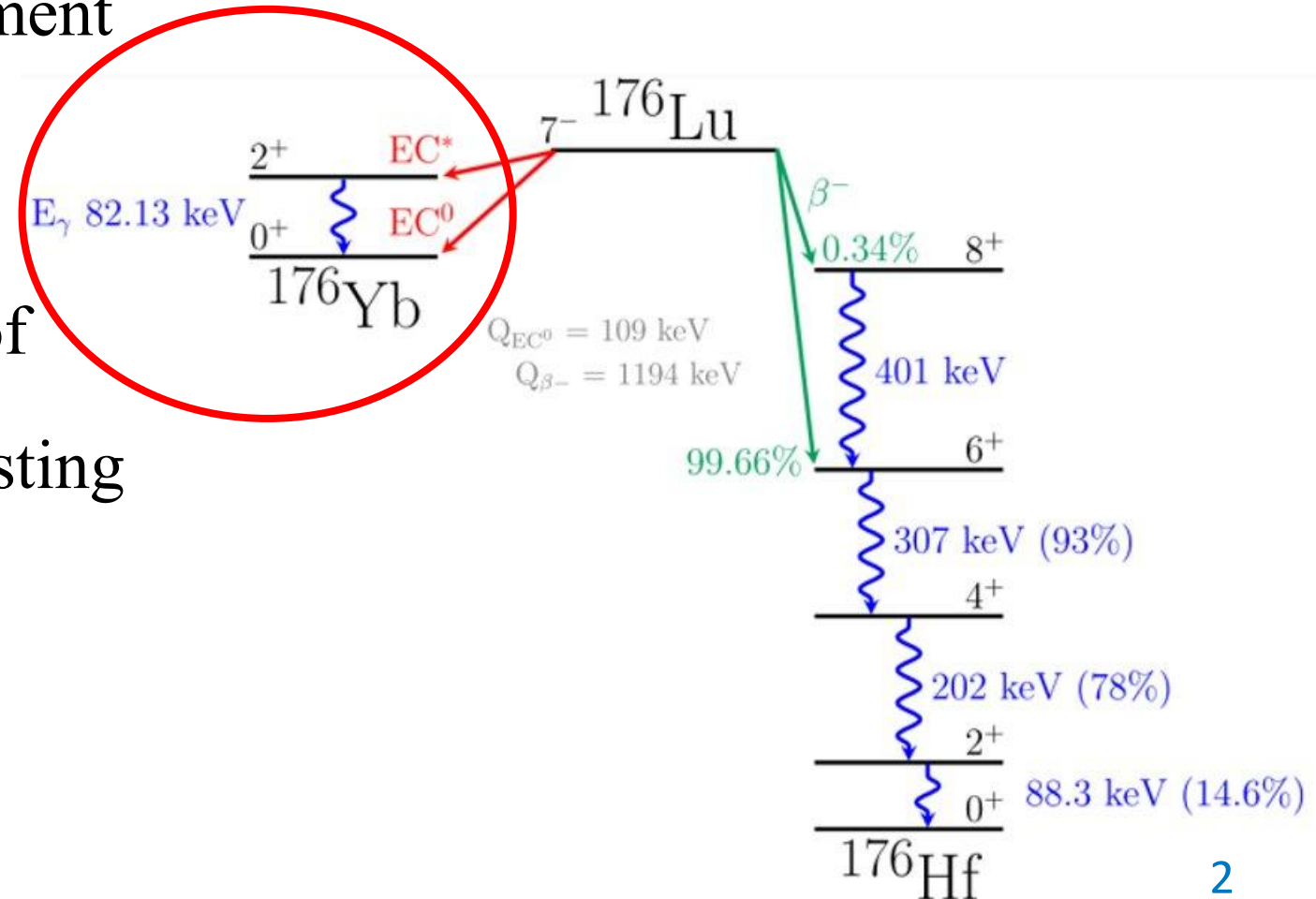

# $^{176}\text{Lu}$ Decay

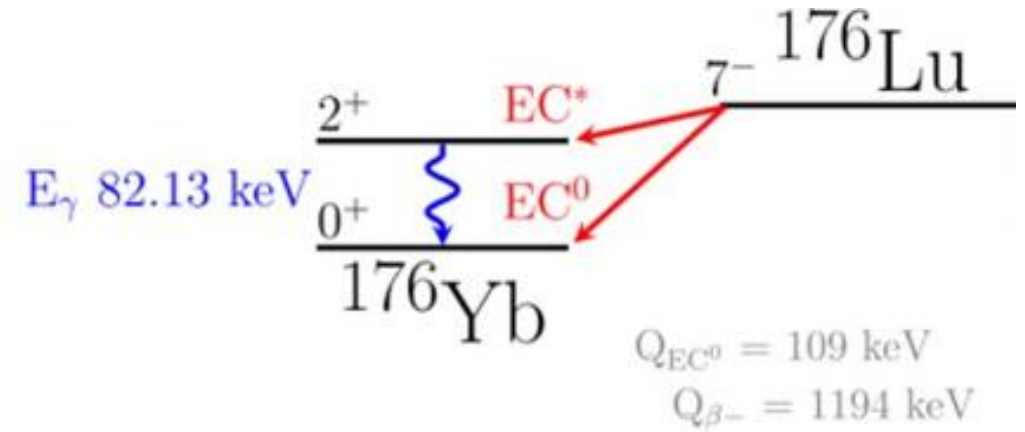

- $^{176}\text{Lu}$  has a fifth forbidden  $\text{EC}^*$  decay
- Current experimental lower limits indicate the half life at  $10^{13}$ - $10^{14}$ y
- Current theoretical limits:  $>1 \times 10^{19}$  y
- LYSO Crystal Source

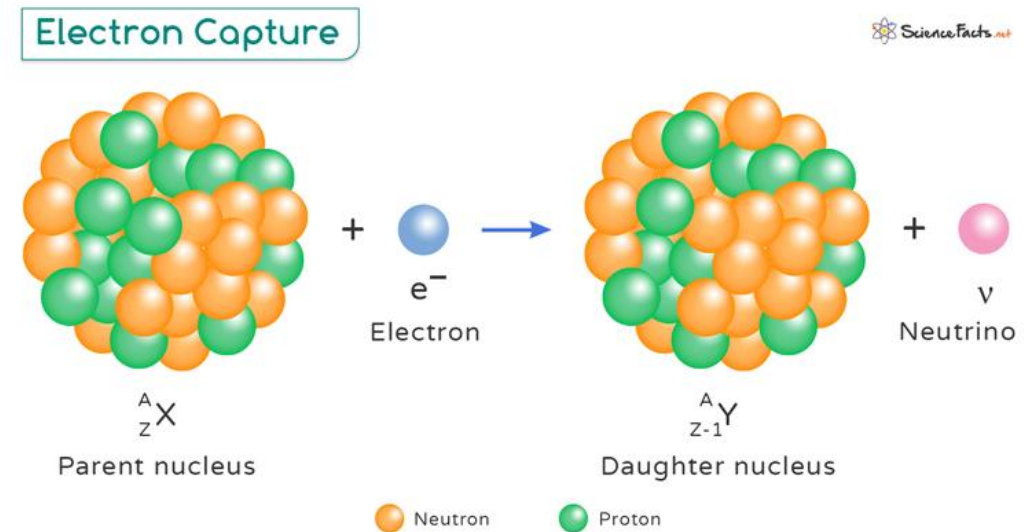
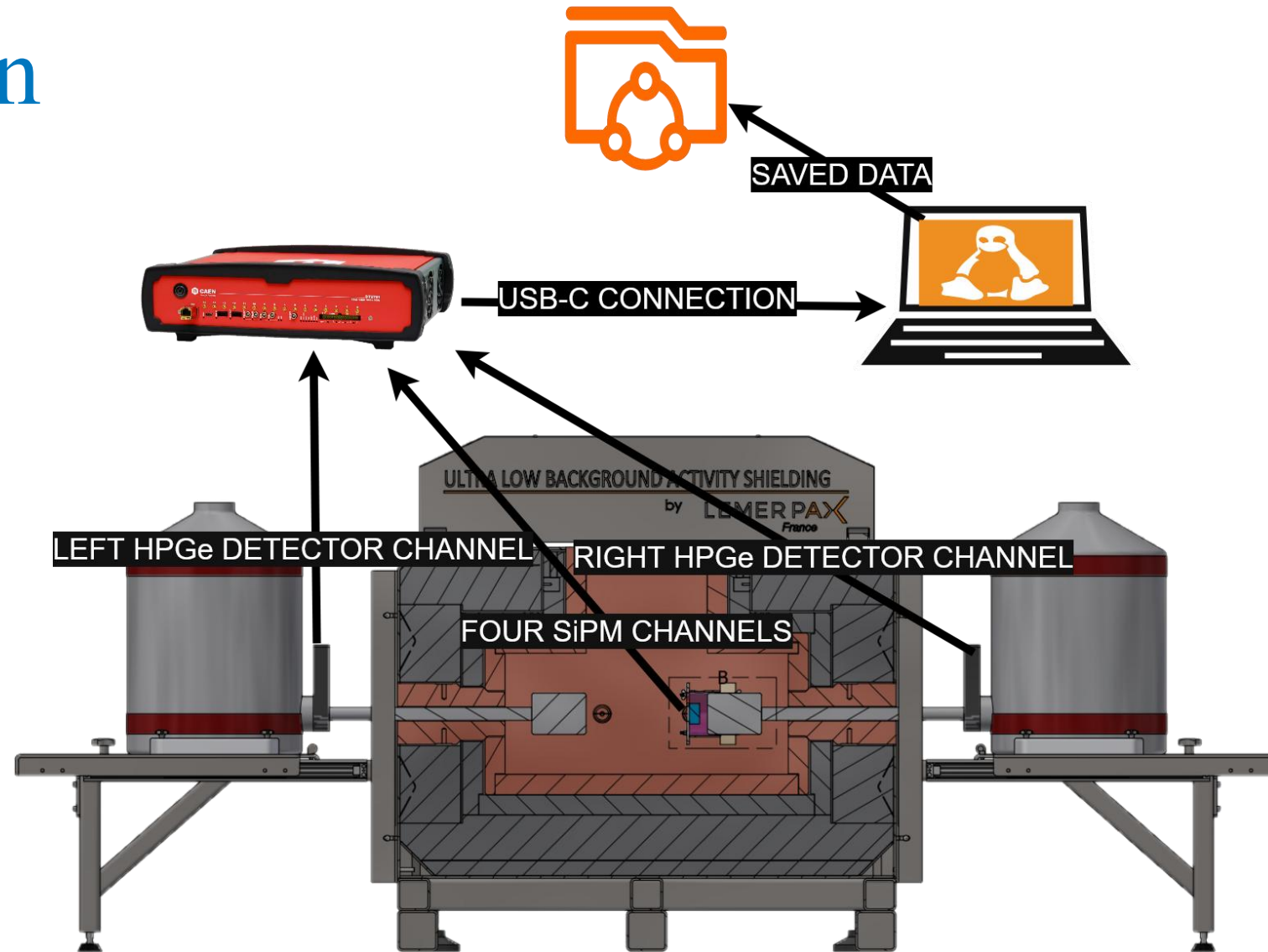

Figure 2: Electron capture process diagram (Source: *Science Facts*)

# Experiment Design

## Dual Coincidence Design

1. CTBT High Purity Germanium Detector (Health Canada)
2. Silicon Photomultiplier (Canadian Nuclear Laboratories)



# Experiment Design

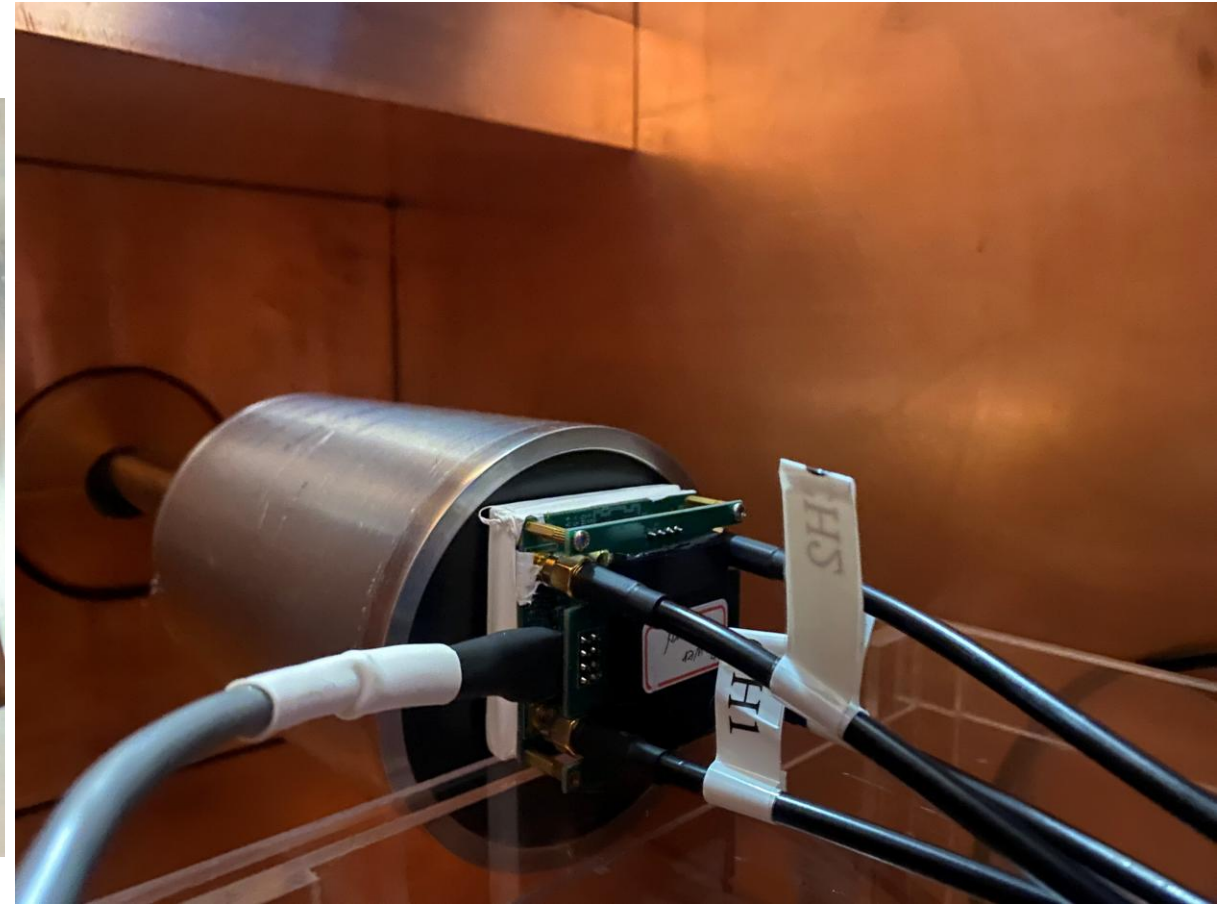

## 27keV cut

- When measuring with purely our HPGe, the  $\beta^-$  overpowers our signal
- How to remove?
- EC Q-value = 109 keV
- $\gamma$  ray is 82.13 keV, leaving the rest of the energy to be scintillated as 26.87 keV light
- Coincidence helps us with this!

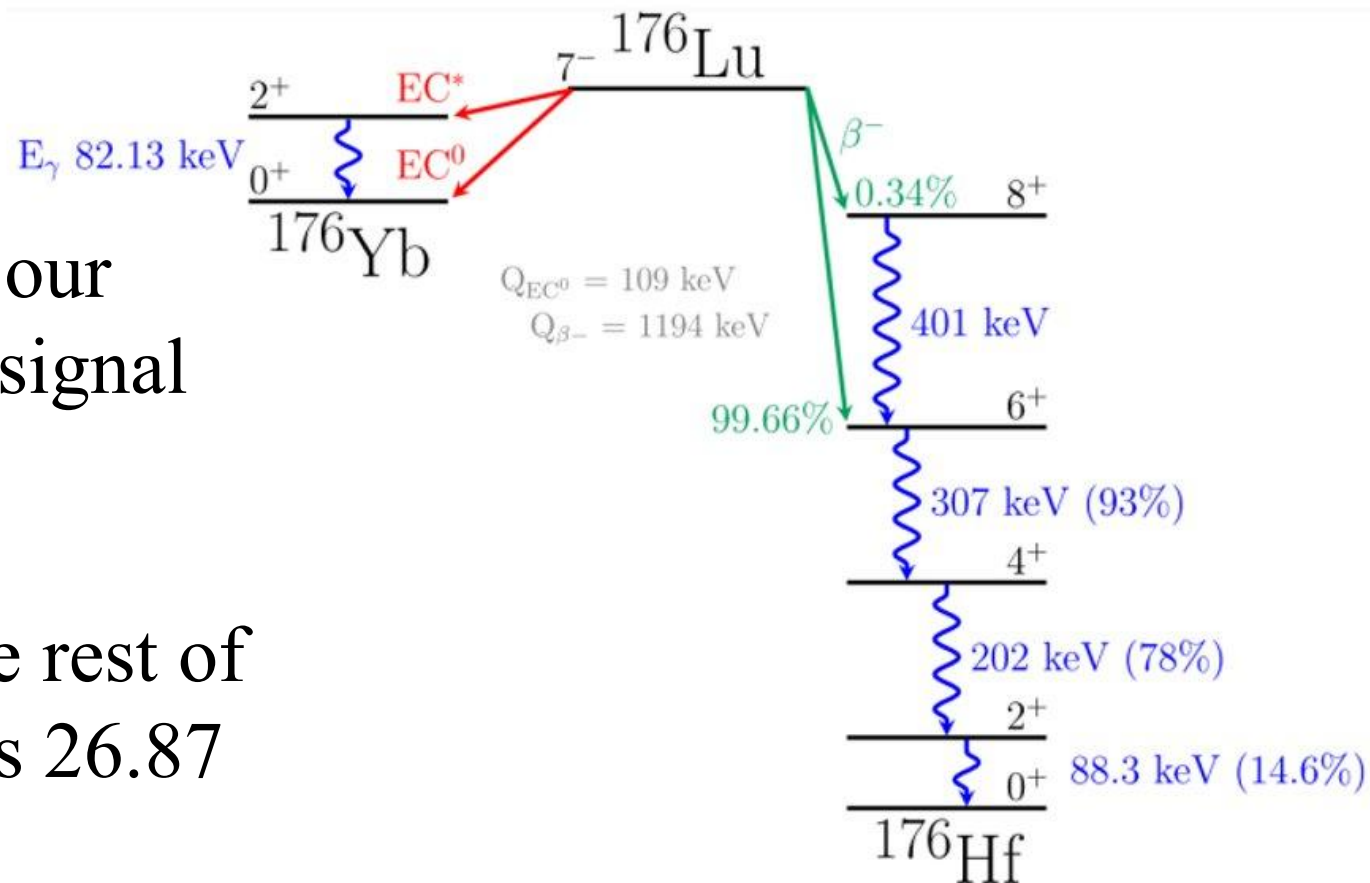

$$Q_{\text{EC}^*} = 109 \text{ keV} - 82.13 \text{ keV} = \boxed{26.87 \text{ keV}}$$

# Science Run 1

- Over four days, we took over 20 Tb of waveform data
- Calibration data with Eu152, Fe55, Ba133
- Worked out very well, ran overnight, with no dead time
- Over 30 hours of science data!



Some of our first pulses!

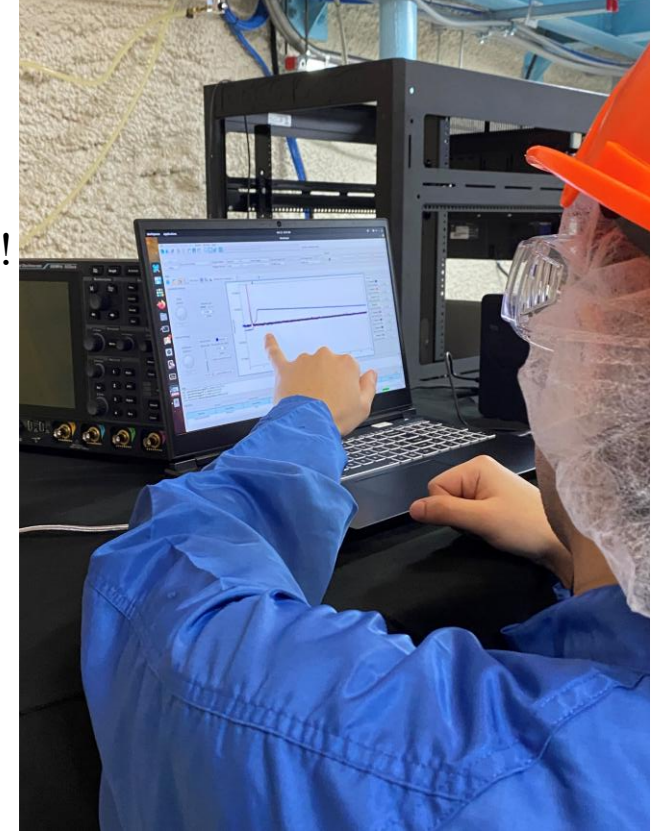
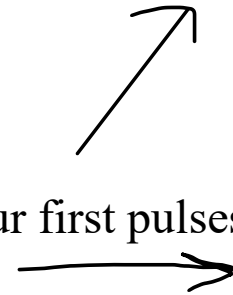

# Preliminary Results

SiPM+ HPGe Waveforms — Bin 70 [22075.3, 22390.7) mV-samples  
RAMPS\_Science\_Run\_1\_Data\_HPGE\_Trigger\_Only\_Overnight\_Run\_2

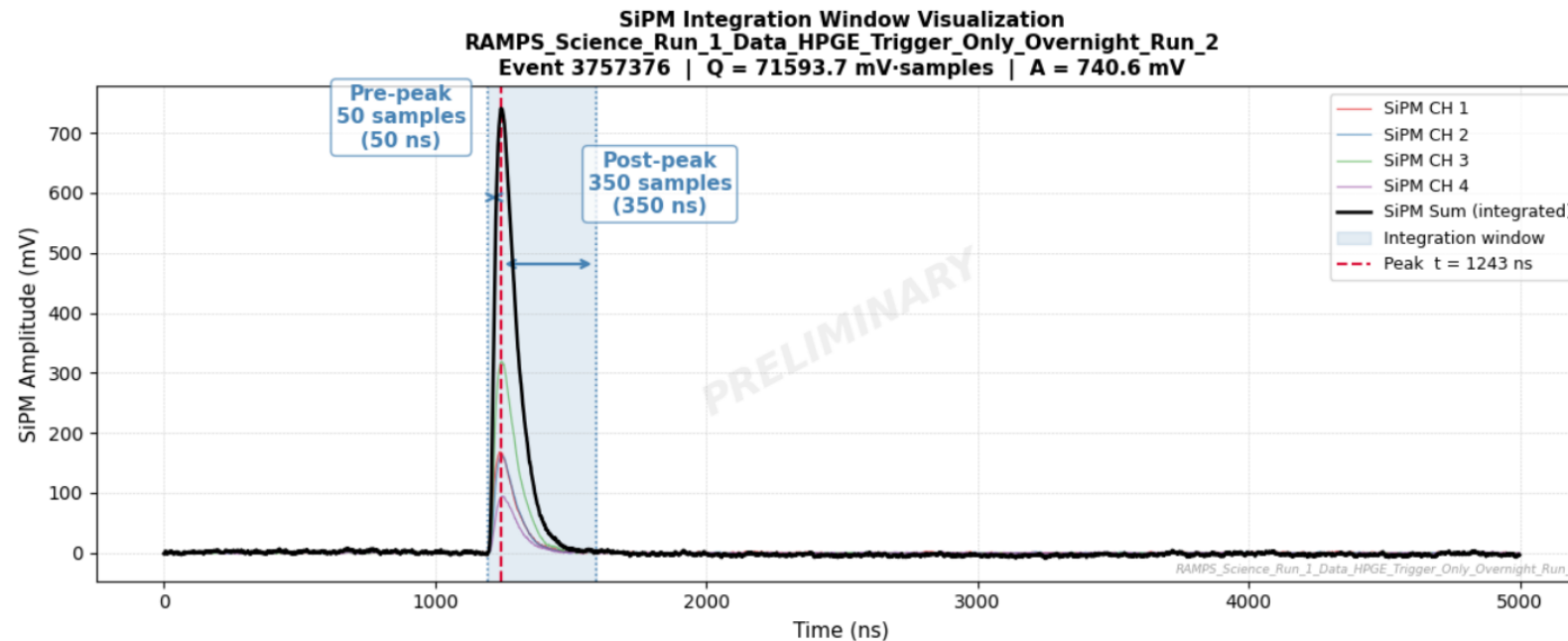
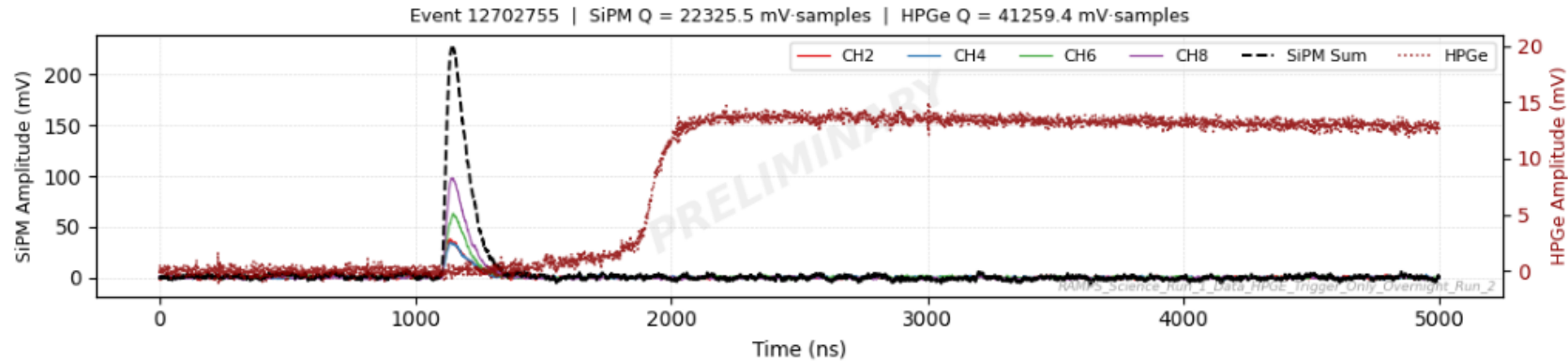

# Preliminary Results

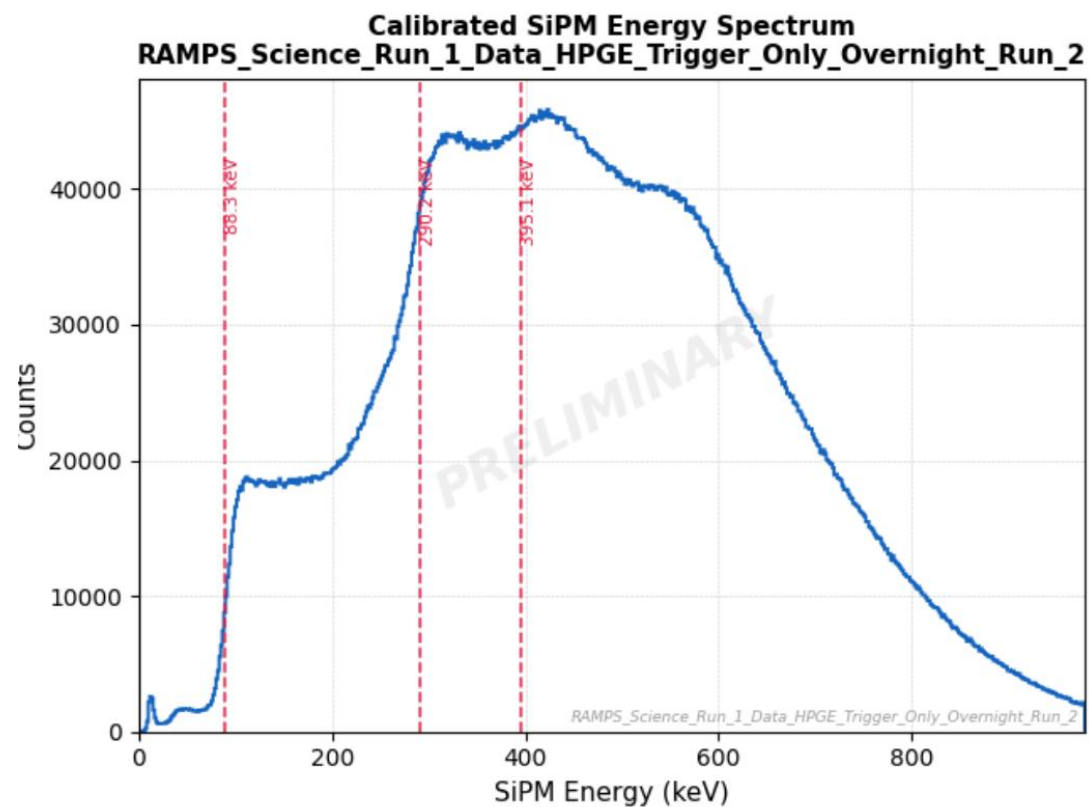

**Energy-Calibrated HPGe Spectrum**  
 Lu176 — RAMPS\_Science\_Run\_1\_Data\_HPGE\_Trigger\_Only\_Overnight\_Run\_2

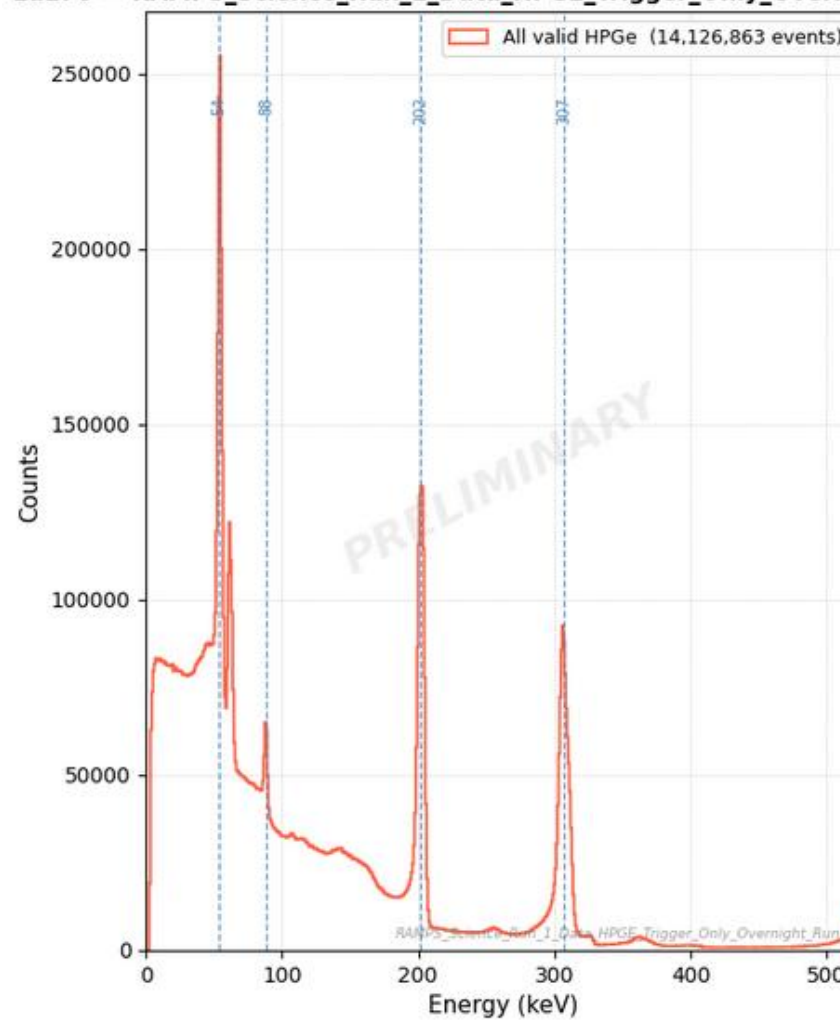

# Preliminary Results

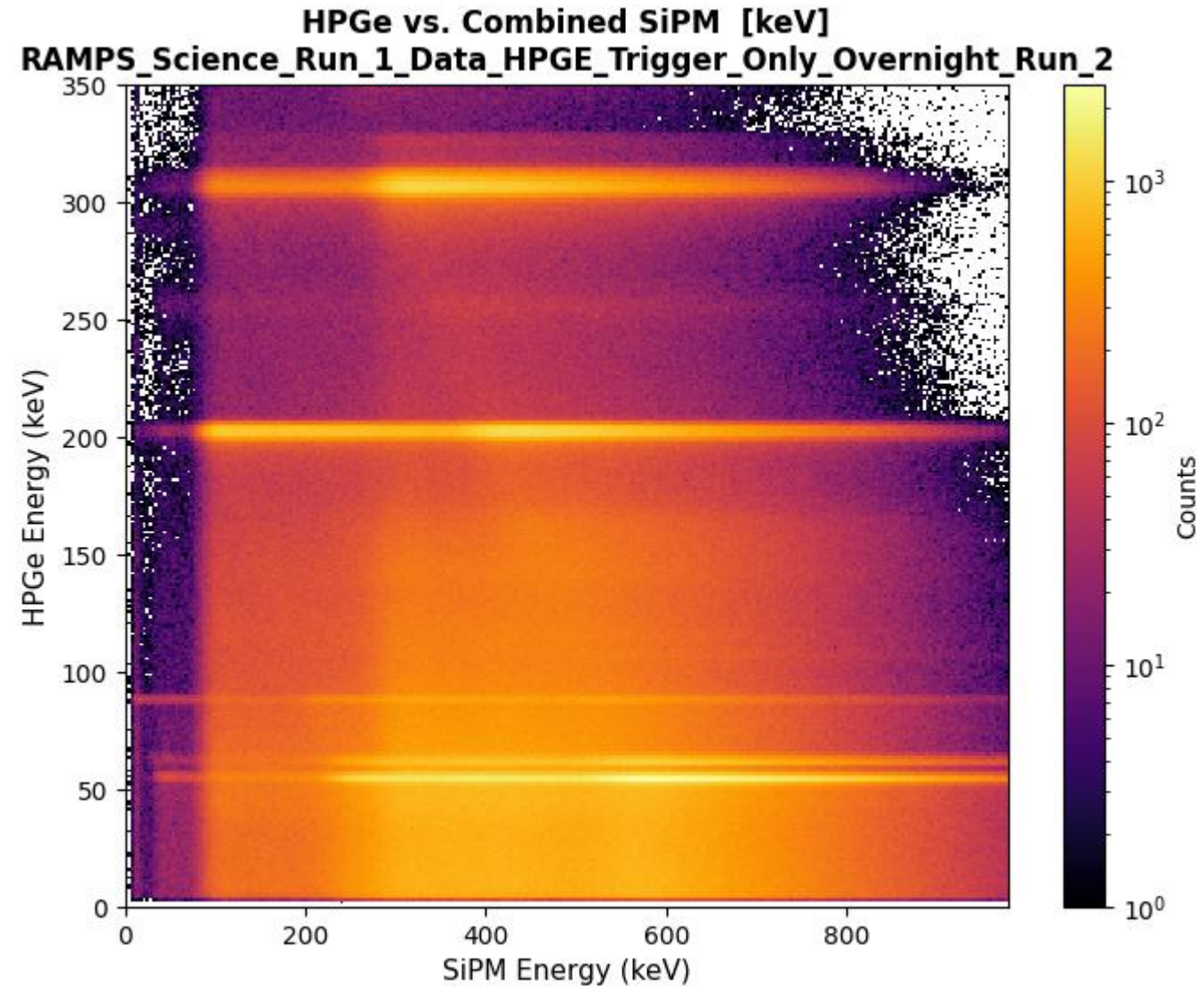

# Preliminary Results

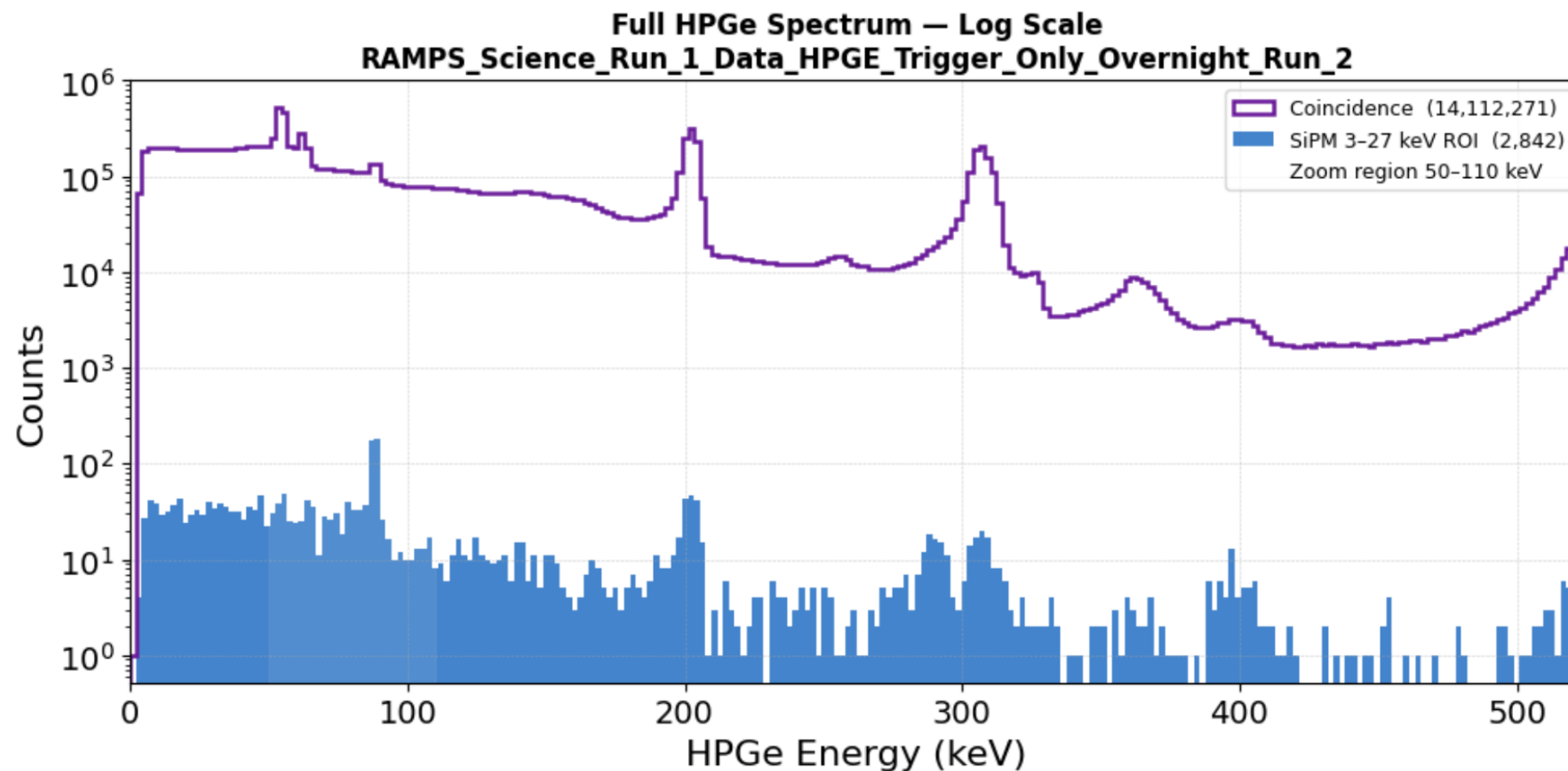

# Preliminary Results

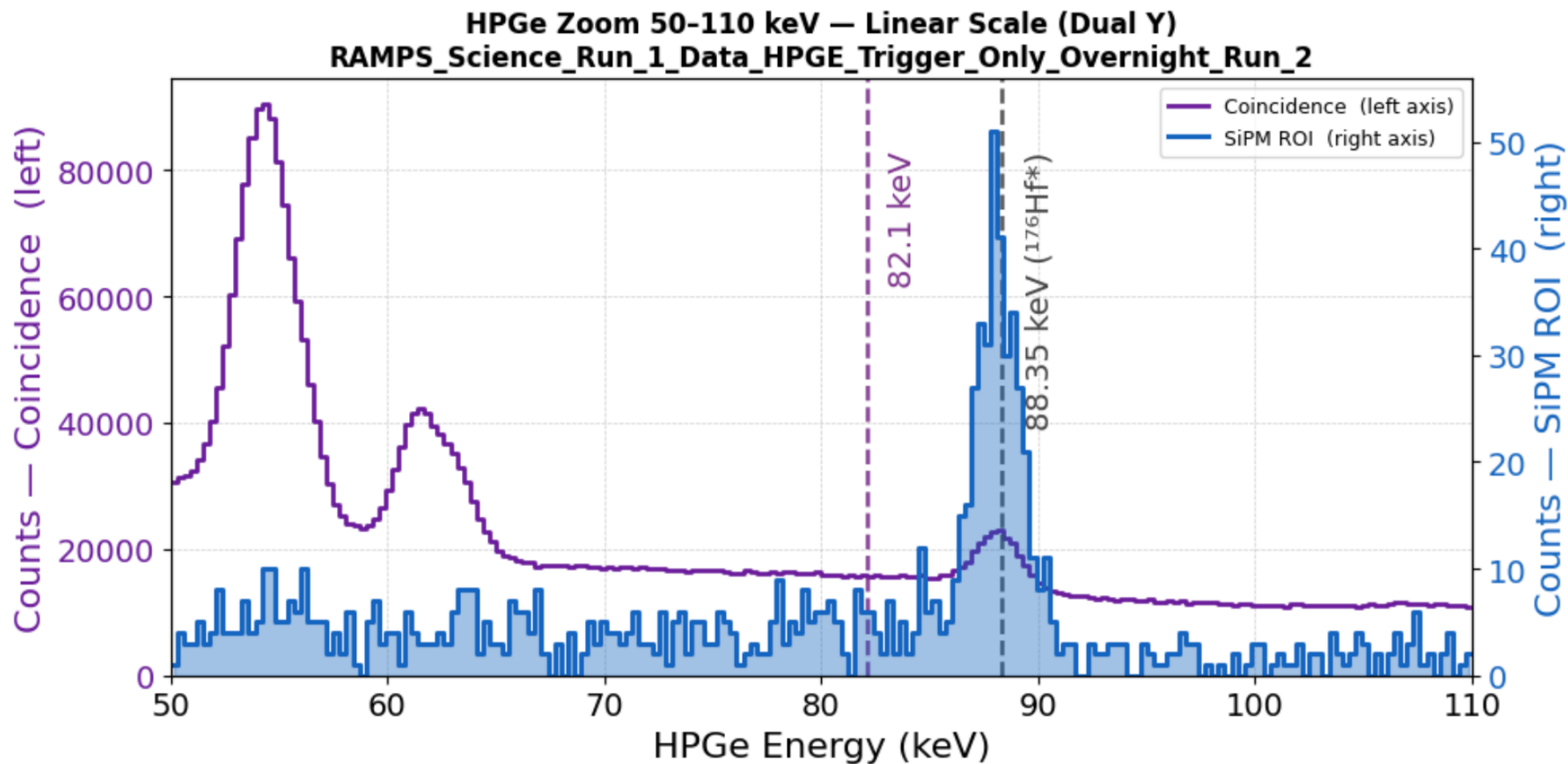

# Moving Forward

Further analysis of our data with the 27 keV cut

Improvements for next Science Run:

- New Silicon Photomultiplier
- SiPM holder will be machined
- Left HPGe Detector to be available
- NAS Data storage system

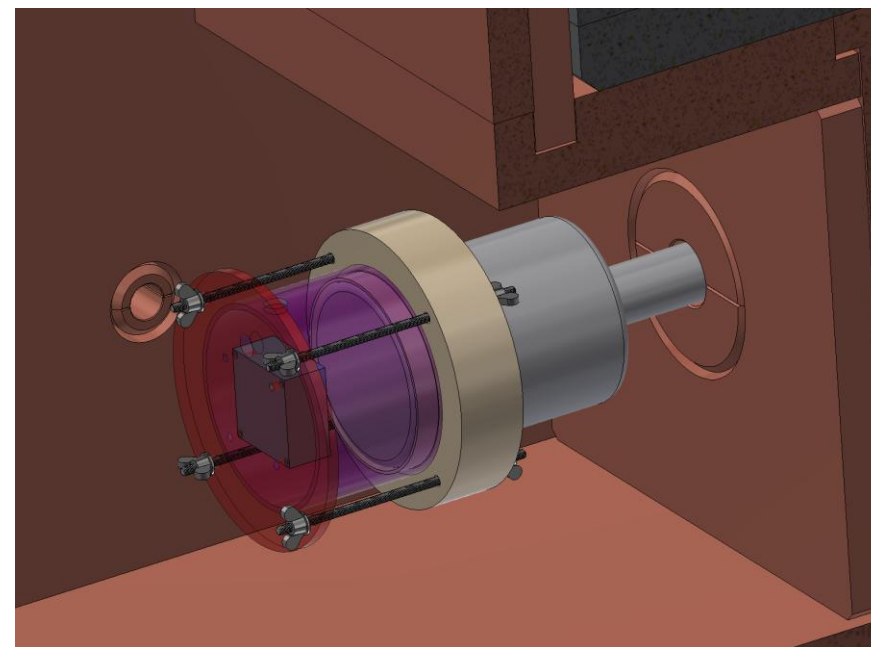
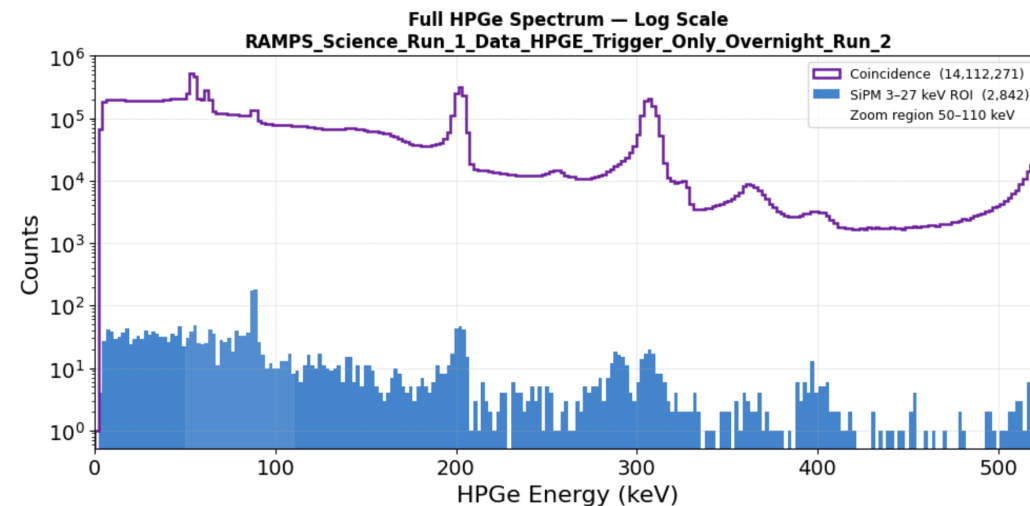

# Conclusion

- Very exciting winter term
- Successful Science 1 run
- Great results
- Many improvements are on the way!



# Great Thanks!

Matthew Stukel, Hector Herrera, Ian Lawson, Steffon Luoma, CAEN Support,  
& everybody else who helped me along the way

Questions?

HPGe Zoom 50-110 keV — Log Scale  
 RAMPS\_Science\_Run\_1\_Data\_HPGE\_Trigger\_Only\_Overnight\_Run\_2

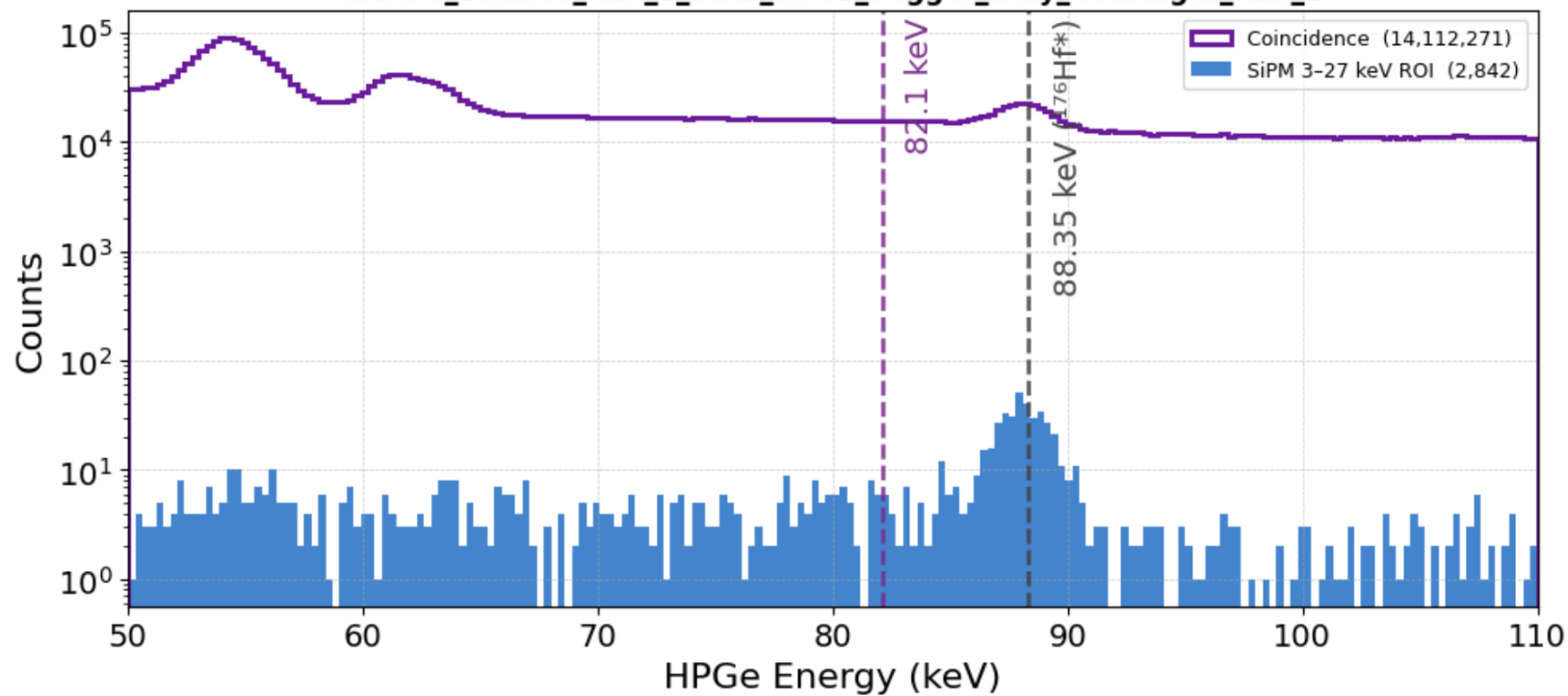

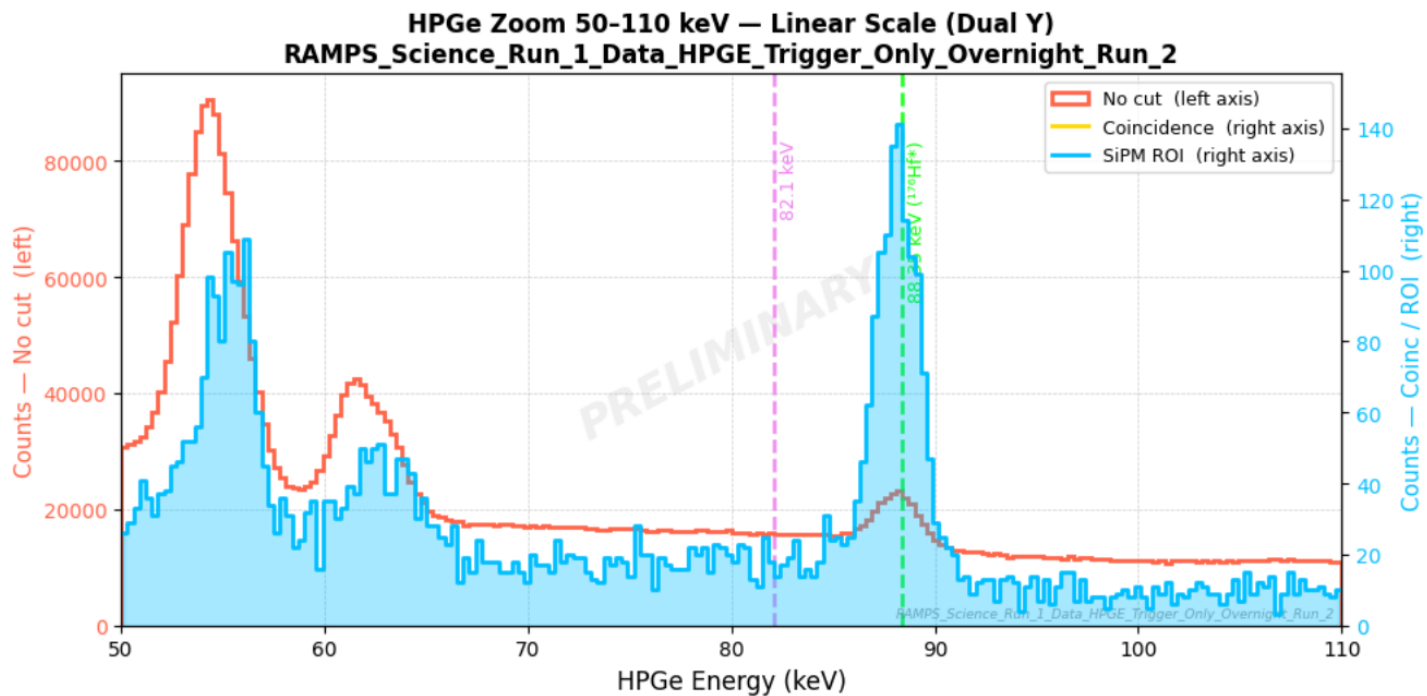
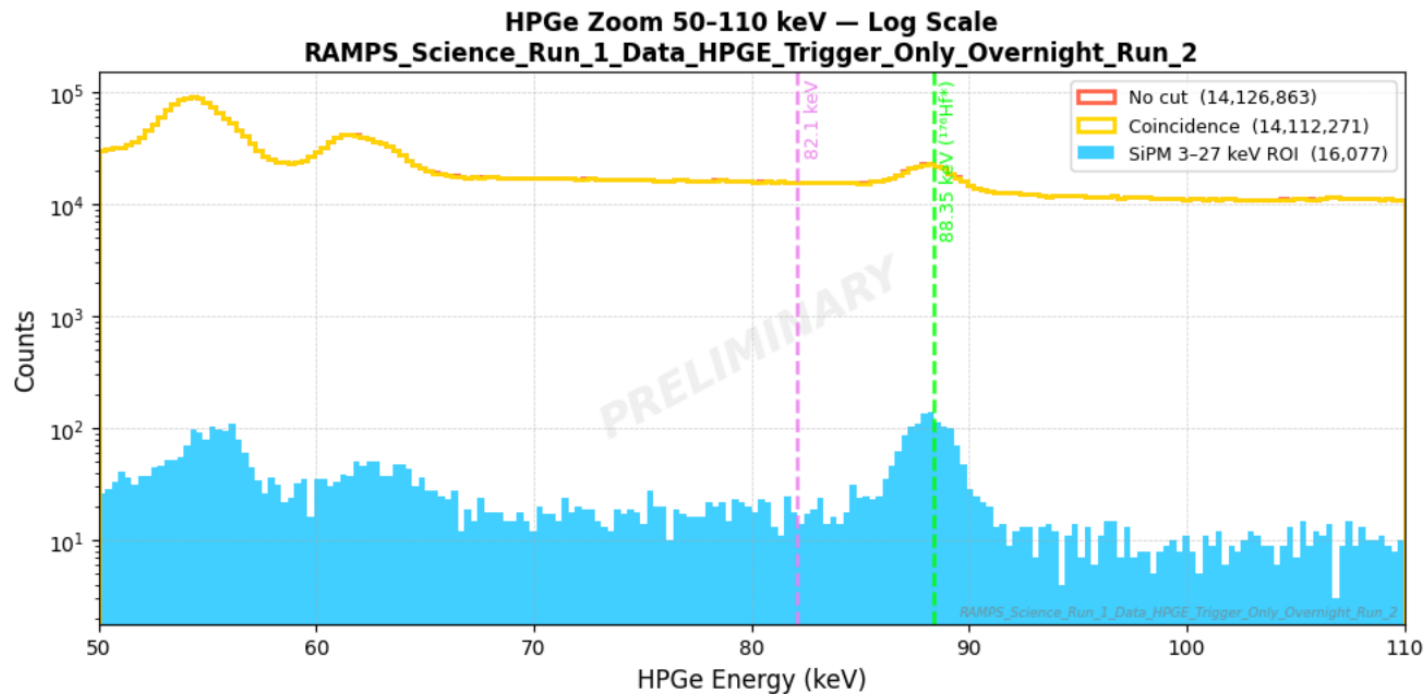

## HPGe Energy Calibration Summary — Lu176 — RAMPS\_Science\_Run\_1\_Data\_HPGE\_Trigger\_Only\_Overnight\_Run\_2

HPGe Energy Calibration — Lu176  
 RAMPS\_Science\_Run\_1\_Data\_HPGE\_Trigger\_Only\_Overnight\_Run\_2 Lu176 — RAMPS\_Science\_Run\_1\_Data\_HPGE\_Trigger\_Only\_Overnight\_Run\_2

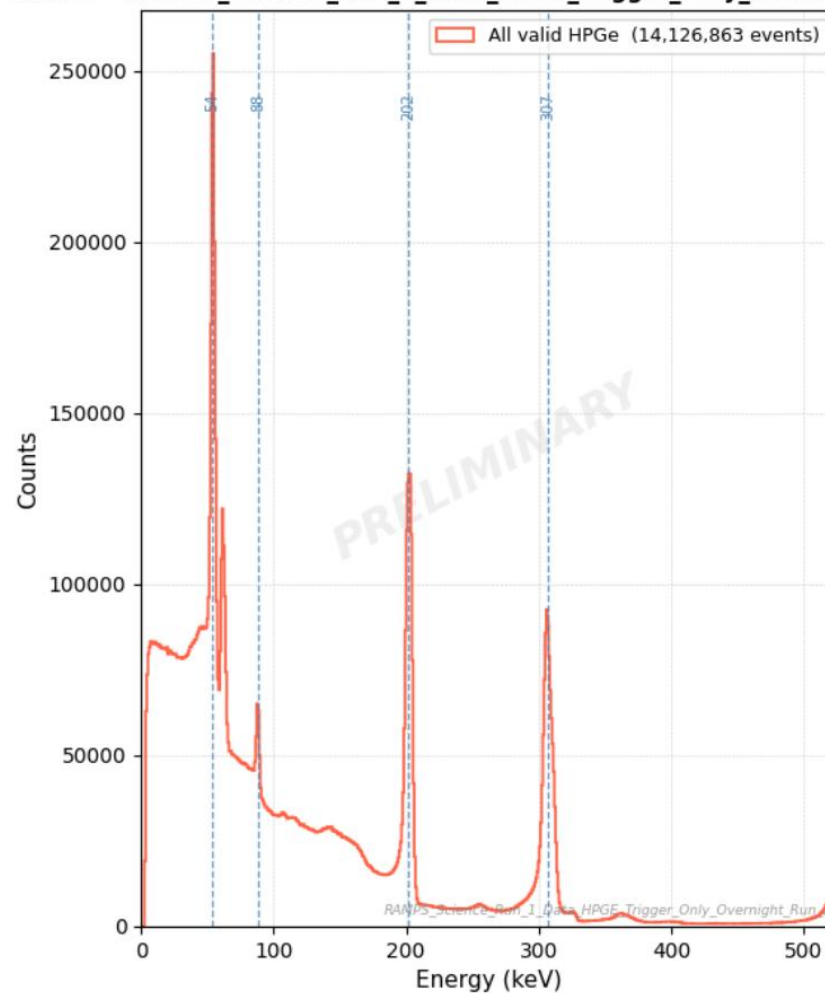
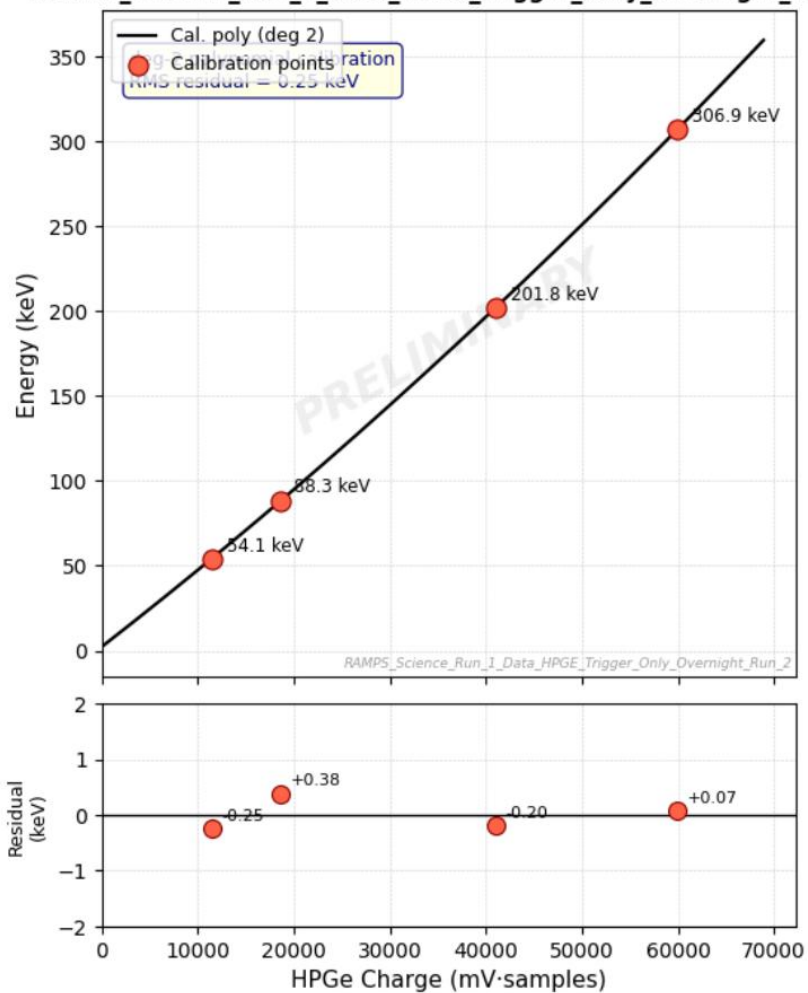

### SiPM Charge vs. Amplitude Spectra (overlaid) RAMPS\_Science\_Run\_1\_Data\_HPGE\_Trigger\_Only\_Overnight\_Run\_2

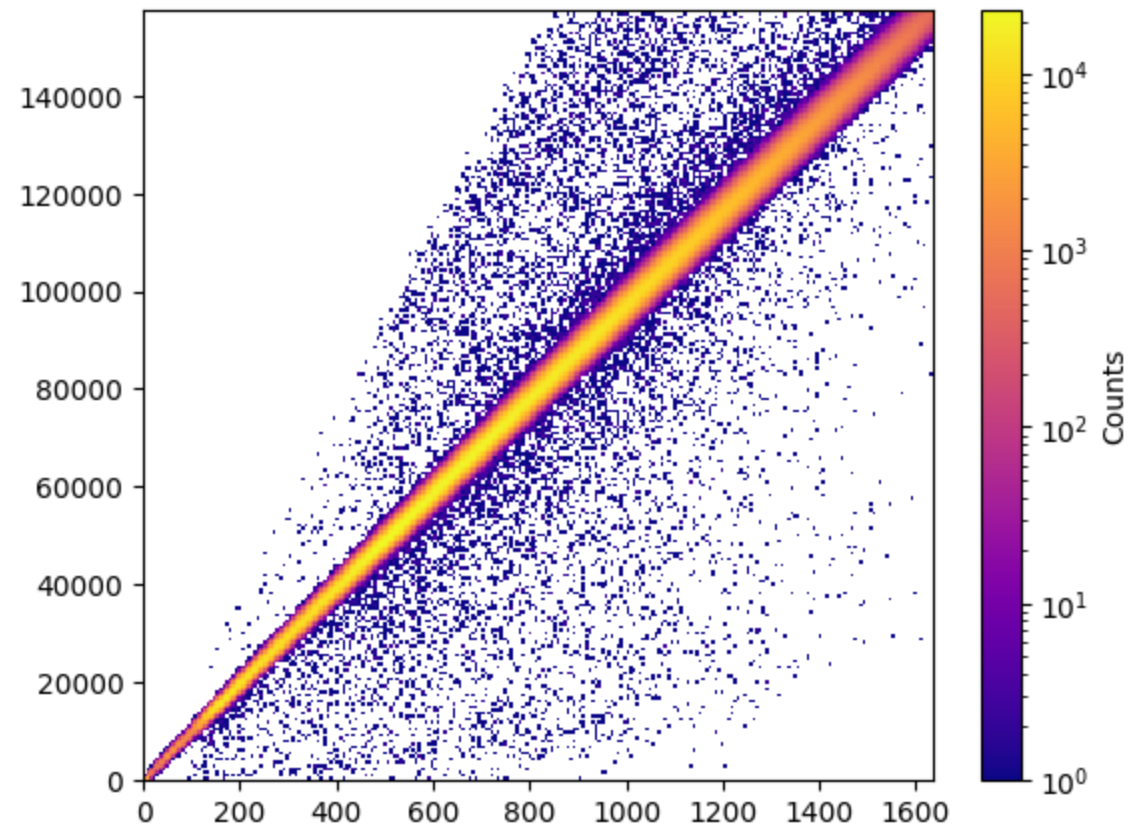
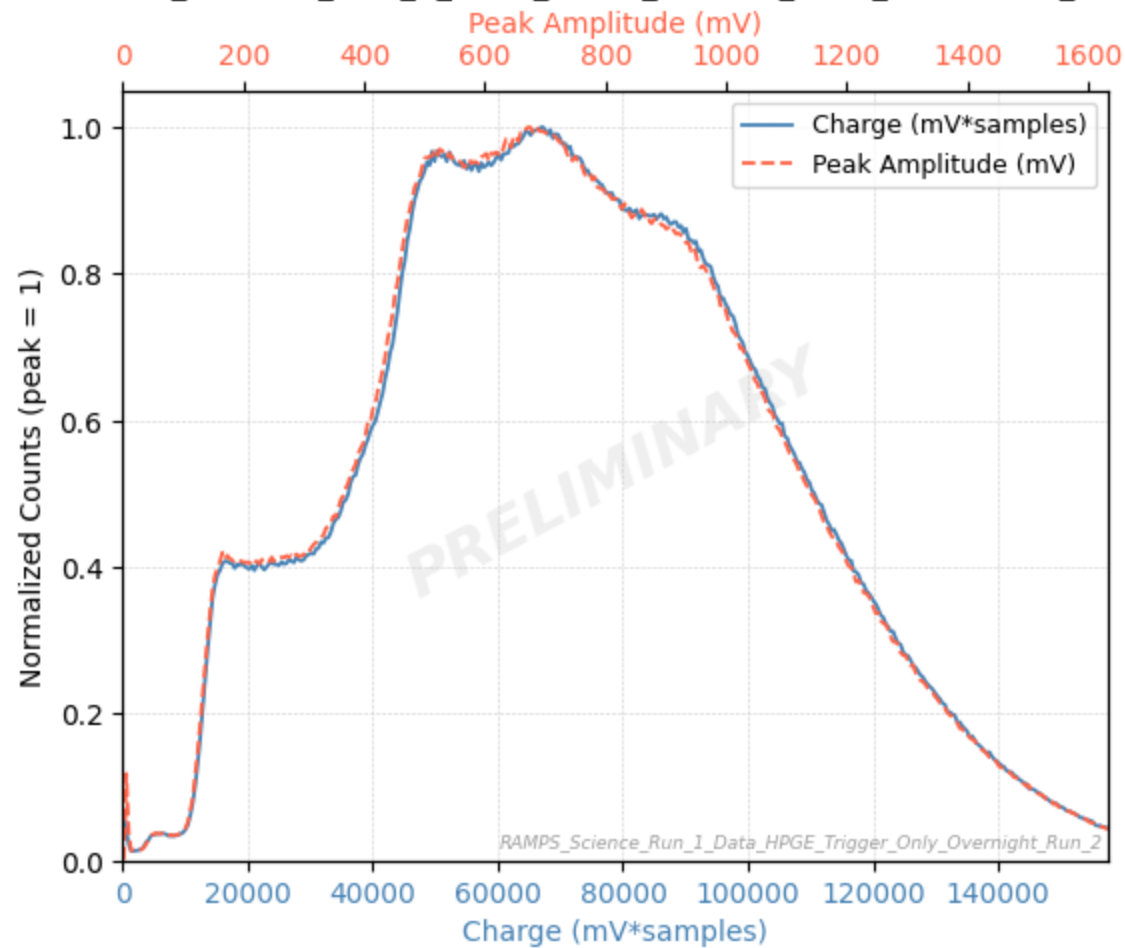

Detected 4 candidate peaks:

Label	Charge (mV·s)	Deriv. height	Hist. counts
P0	3979.5	35.8	719
P1	12933.5	488.2	6181
P2	44438.3	263.9	22874
P3	63175.3	35.6	27851

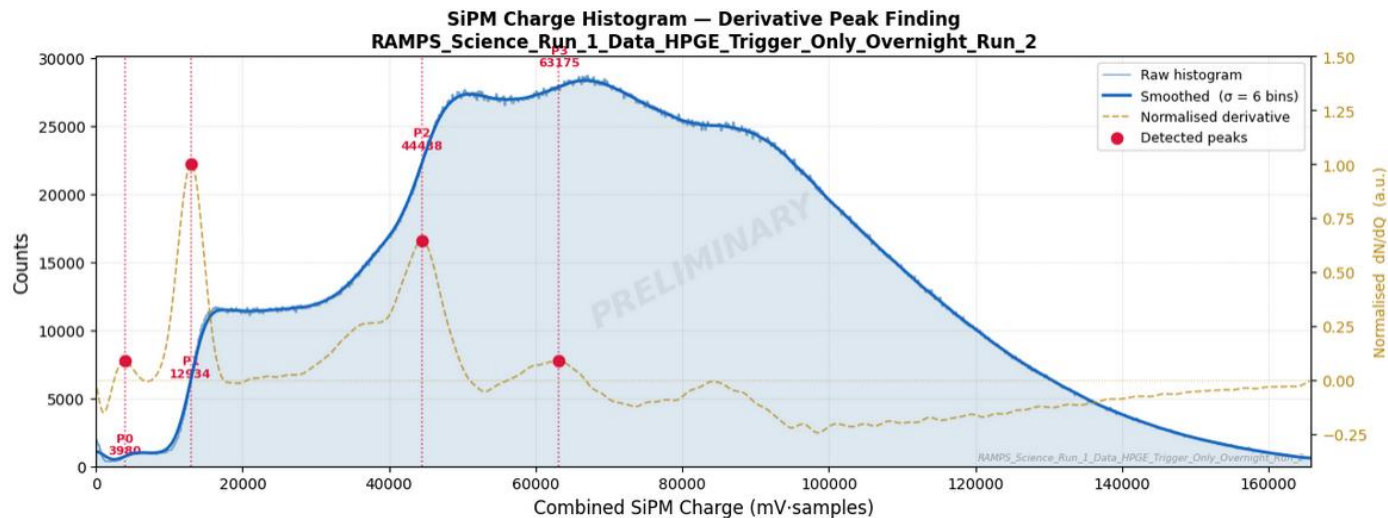

P1: 12933.5 mV·s → 88.35 keV  
 P2: 44438.3 mV·s → 290.18 keV  
 P3: 63175.3 mV·s → 395.13 keV

SiPM Calibration:  $E = 0.006137 \cdot Q + 11.2754$  keV  
 Slope : 0.0061373 keV / (mV·s)  
 Offset : 11.2754 keV  
 RMS : 4.412 keV

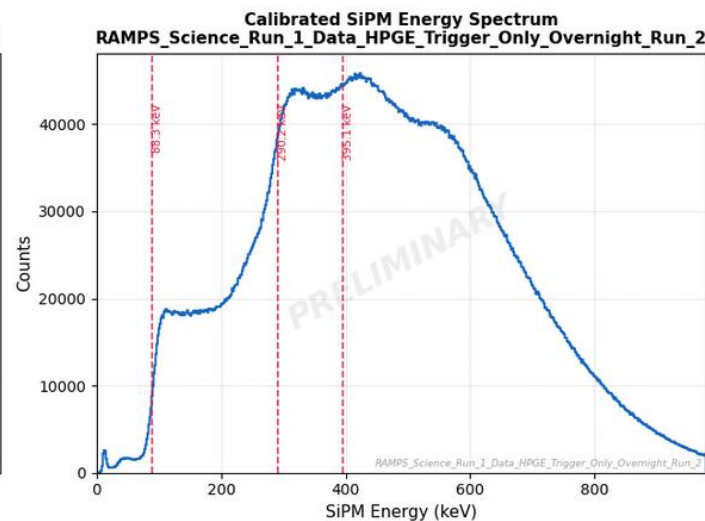
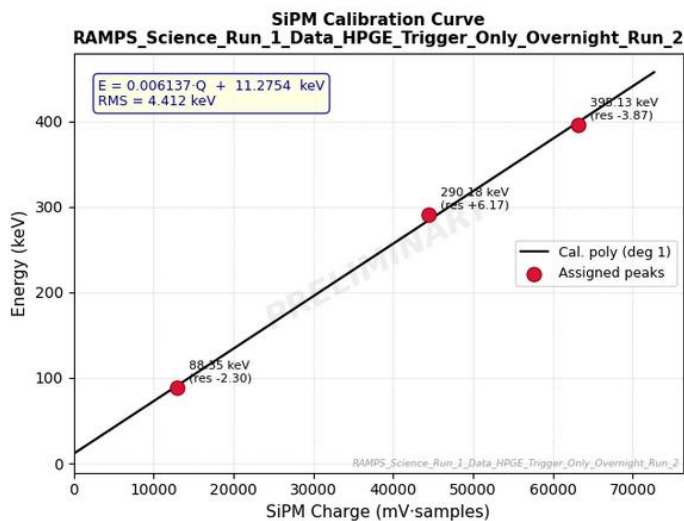

HPGe Energy Calibration — Lu176  
RAMPS\_Science\_Run\_1\_Data\_HPGE\_Trigger\_Only\_Overnight\_Run\_2

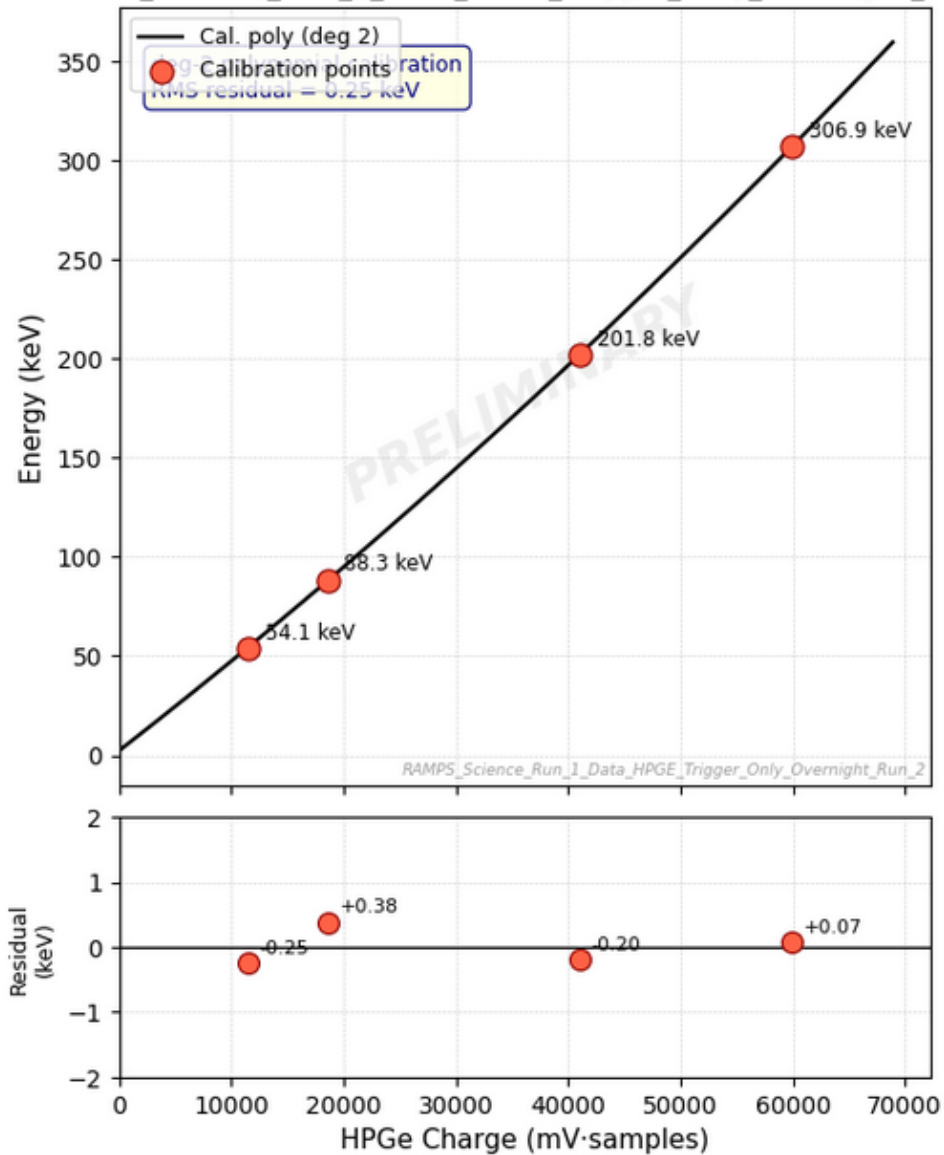

Energy-Calibrated HPGe Spectrum  
Lu176 — RAMPS\_Science\_Run\_1\_Data\_HPGE\_Trigger\_Only\_Overnight\_Run\_2

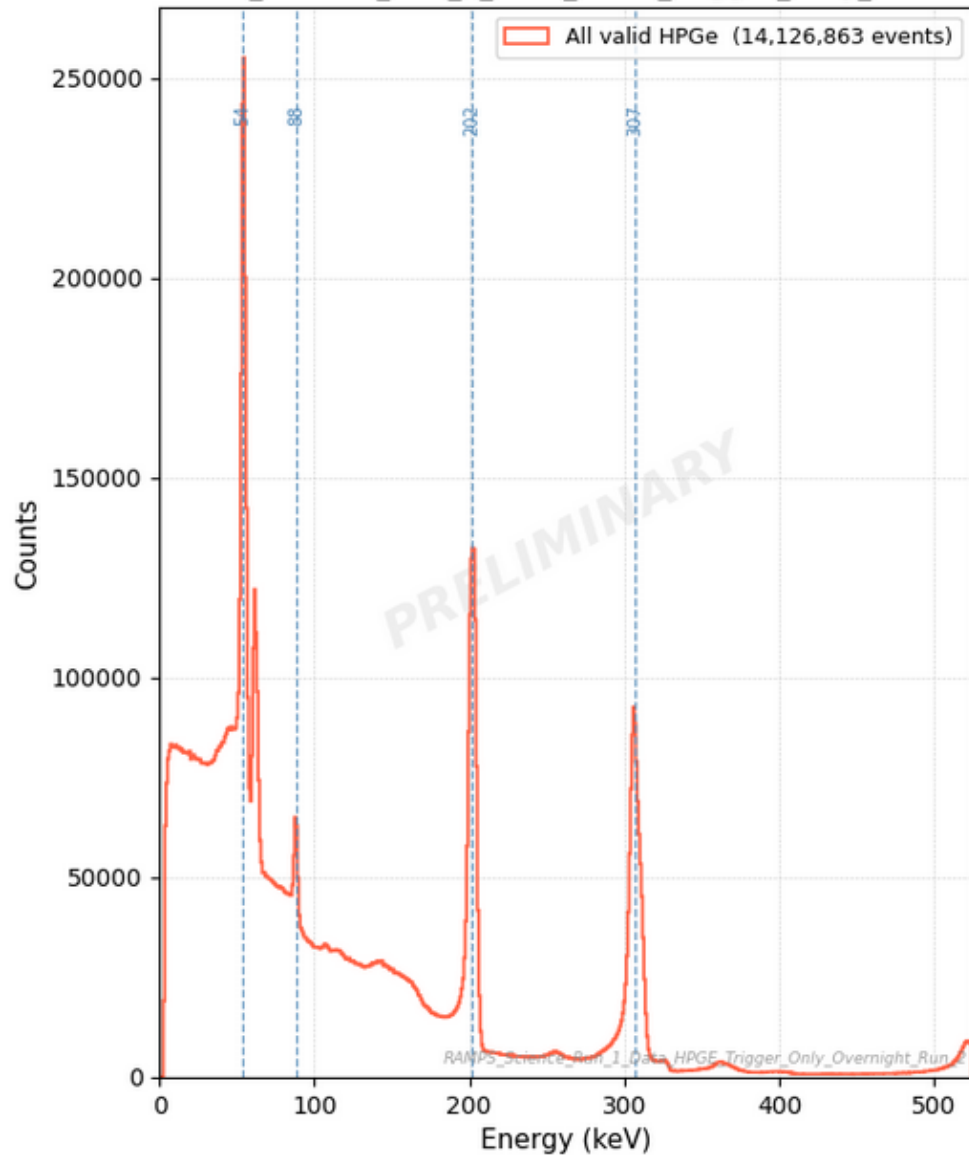

B

hpge\_energy\_keV stored — 14,126,863 valid events.

Energy range : 1.8 - 1845.5 keV

